

**WALL MOUNT BRACKET**

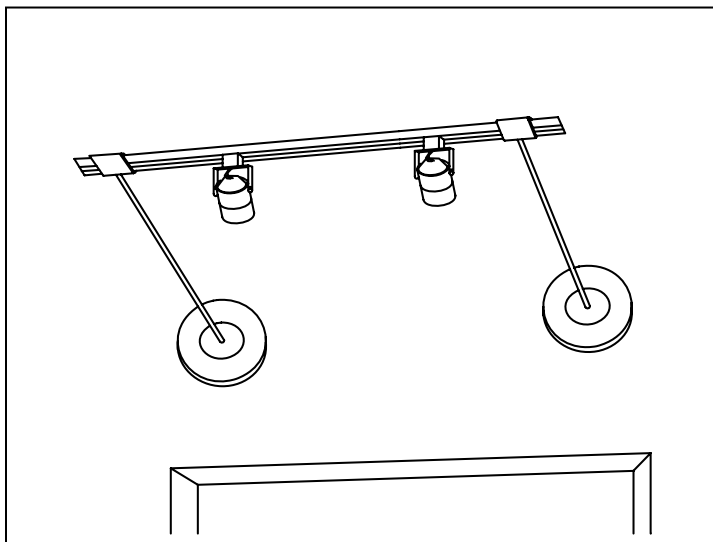

MODEL	FINISH	DIMENSIONS		
		CANOPY DIAMETER	CANOPY DEPTH	LENGTH
SWB-BK	BLACK	4 3/4"	1 1/4"	16"
SWB-WT	WHITE	4 3/4"	1 1/4"	16'

USED WITH 4' OR 8' TRACK CARRIER\*. KIT CONSISTS OF TWO CANOPIES, ROD AND CARRIER BRACKETS USE TWO FOR EACH TRACK SECTION. POWERED FROM A REMOTE TRANSFORMER THROUGH A LIVE END CONNECTOR.

- INSTRUCTIONS AND MOUNTING HARDWARE INCLUDED
- UL AND CUL LISTED

KITS ARE ONLY COMPATIBLE WITH THE W.A.C LINEAR SYSTEM ONLY.  
COMPONENTS AVAILABLE IN KITS, NOT SOLD SEPARATELY.

\* TRACK CARRIER SOLD SEPARATELY