

| | |
|-----------------------|-------------|
| CATALOG NUMBER | TYPE |
| PROJECT | |

MONORAIL – SURFACE MOUNT TRANSFORMER

MODEL LM-EN24-600M

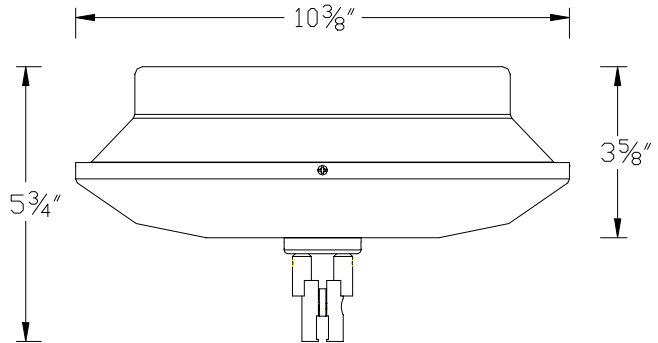

| Ordering Matrix | | |
|-----------------|-------------|----------------|
| Model | Part Number | Finish |
| | | |
| LM-EN24 | 600M | BZ CH PT |

Ordering Example (*model number – part number – finish*): LM-EN24-600M-BZ

| Product Details | |
|------------------------|--|
| Description: | Surface mount magnetic low voltage transformer for the W.A.C. monorail system. The canopy style enclosure includes the transformer and the track power feed adaptor. |
| Catalog Number: | LM = Low voltage monorail EN24 = 24 volt, enclosed canopy transformer 600M = 600 watt magnetic |
| Input: | 120V (50/60Hz) |
| Output: | 24V |
| Min Load: | 20W |
| Max Load: | 600W |
| Max Input Amp: | 5.0A (@ 120V) |
| Mounting: | Installs to a standard junction box. Total weight = 25 lbs. The standard LM-EN24-600M configuration matches the height of the 5 3/4" standoffs (LM-X5). |
| Finish: | Available in Bronze (BZ), Chrome (CH), and Platinum (PT). |
| Listing: | UL & CUL Listed. |

| Specification Features |
|--|
| <ul style="list-style-type: none"> • Dims with magnetic low voltage dimmers. • Output circuit breaker located on the upper lip of the canopy enclosure is a magnetic push to reset type. • Contains integral de-buzzing coil. • The surface mount canopy transformer is an ideal choice when the installation is on an existing ceiling. • 2 year W.A.C. Lighting product warranty. |