

<b>CATALOG NUMBER</b>	<b>TYPE</b>
<b>PROJECT</b>	

**MONORAIL – SURFACE MOUNT TRANSFORMER** **MODEL LM-EN12-150E**

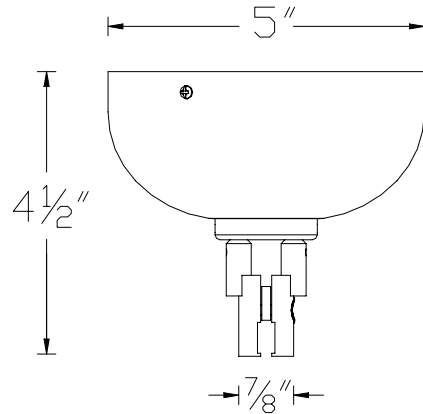

Ordering Matrix		
Model	Part Number	Finish
LM-EN12	150E	BZ    CH    PT

Ordering Example (*model number – part number – finish*): LM-EN12-150E-PT

Product Details	
<b>Description:</b>	Surface mount electronic low voltage transformer for the W.A.C. monorail system. The canopy style enclosure includes the transformer and the track power feed adaptor.
<b>Catalog Number:</b>	LM = Low voltage monorail EN12 = 12 volt, enclosed canopy transformer 150E = 150 watt electronic
<b>Input:</b>	120V (50/60Hz)
<b>Output:</b>	12V
<b>Min Load:</b>	50W
<b>Max Load:</b>	150W
<b>Max Input Amp:</b>	1.25A (@ 120V)
<b>Mounting:</b>	Installs to a standard junction box. Total weight = 2.3 lbs. The standard LM-EN12 configuration matches the height of the 4 1/2" standoffs.
<b>Finish:</b>	Available in Bronze (BZ), Chrome (CH), and Platinum (PT).
<b>Listing:</b>	UL & CUL Listed.

Specification Features
<ul style="list-style-type: none"> <li>• Dims with electronic low voltage dimmers.</li> <li>• Built-in auto reset, soft start, short and overload circuit protection features.</li> <li>• Soft start delayed start feature extends lamp life by limiting abrupt in-rush current to the lamp.</li> <li>• The surface mount canopy transformer is an ideal choice when the installation is on an existing ceiling.</li> <li>• 2 year W.A.C. Lighting product warranty.</li> </ul>