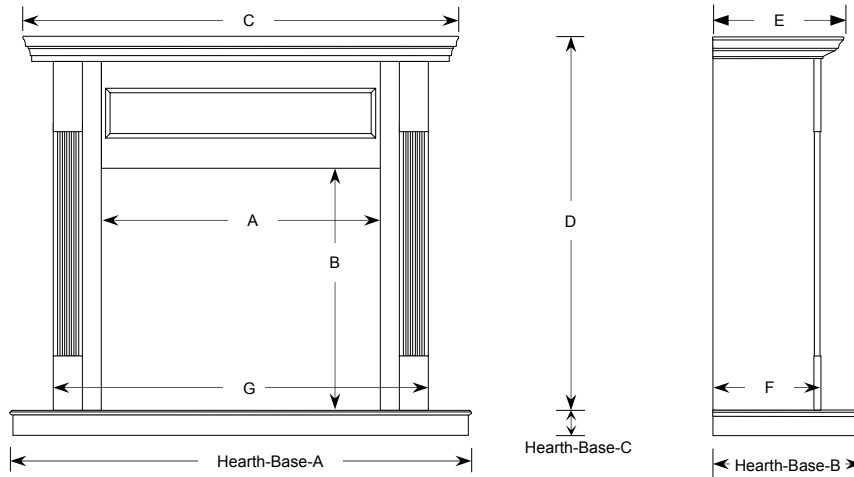
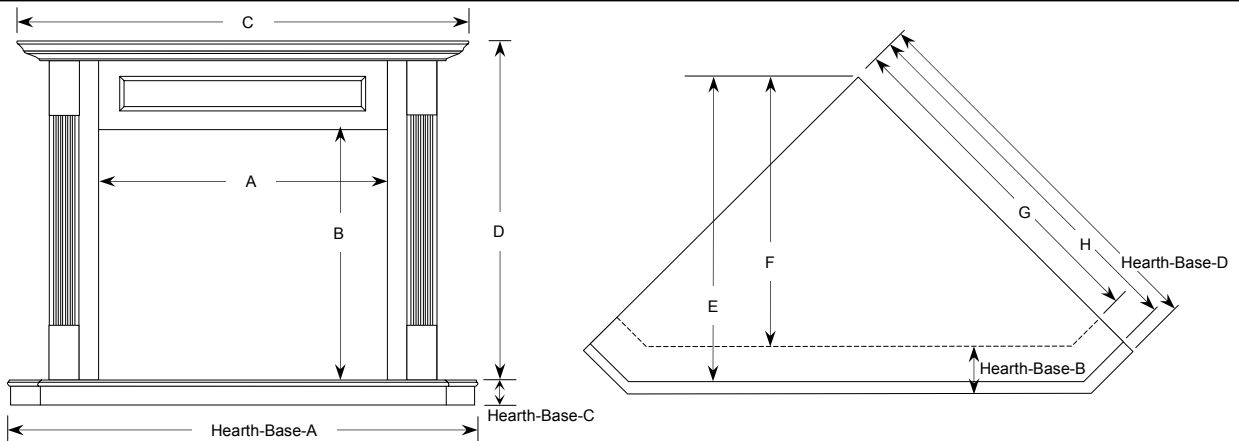


## The **FORESTER** Flat Wall & Corner Fireplace Mantel Cabinets

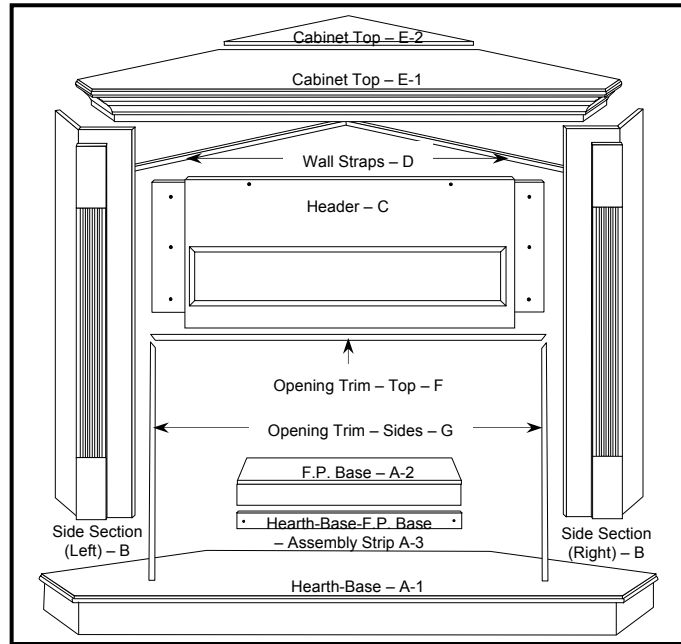
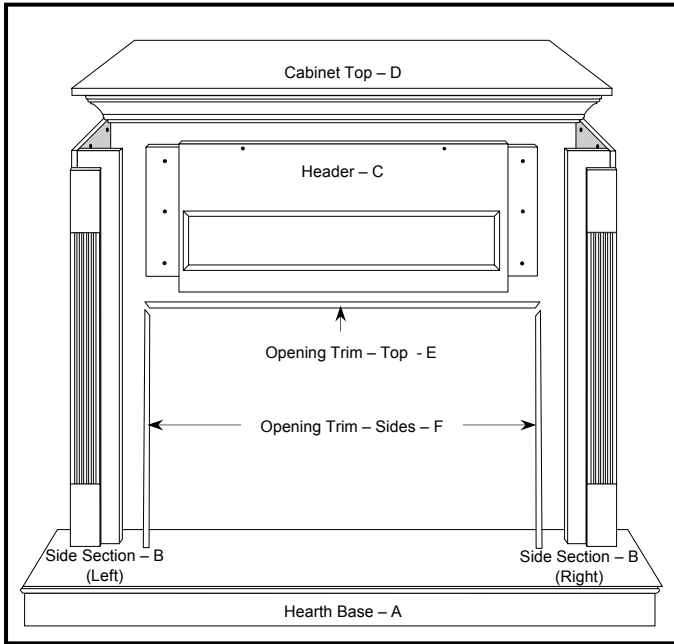


WALL CABINETS	Fits these Vermont Castings Fireplaces	A	B	C	D	E	F	G	HEARTH-BASE			Total Height
									A	B	C	
F0W033 / F0WH33 / F0WW33	DVR33, DEF33, 3DVBR, UVS33	33 ½	29 ¾	52 ½	45 ¾	18 ¾	15 ½	45 ¼	54 ¾	20 ¼	3	48 ¾
F0W036 / F0WH36 / F0WW36	DVRT36, DEF36, 36BDVR, 36BDVT, UVC36, UVS36	36 ½	34 ½	55 ½	50 ½	20 ¾	17 ½	48 ¼	57 ¾	22 ¼	3	53 ½
F0WU036 / F0WUH36 / F0WUW36	UVBR36, UVBC36, DVBR36, BREF36	40 ½	36 ¼	59 ½	52 ¼	25 ¾	22 ½	52 ¼	61 ¾	27 ¼	3	55 ¾
FW1060 / FW1H60 / FW1W60	DV360	41 ½	37 ¾	60 ½	53 ¾	24 ¾	21 ½	53 ¼	62 ¾	26 ¼	3	56 ¾



CORNER CABINETS	Fits these Vermont Castings Fireplaces	A	B	C	D	E	F	G	H	HEARTH-BASE				Total Height
										A	B	C	D	
F0C033 / F0CH33 / F0CW33	DVR33, DEF33, 3DVBR, UVS33	33 ½	29 ¾	59 ¼	45 ¾	35	31 ¼	38 ¼	41 ¾	61 ¾	5 ½	3	42 ¾	48 ¾
F0C036 / F0CH36 / F0CW36	DVRT36, DEF36, 36BDVR, 36BDVT, UVC36, UVS36	36 ½	34 ½	62 ¼	50 ½	36 ½	32 ¾	40 ¾	44	64 ¾	5 ½	3	44 ¾	53 ½

# The Forester Flat Wall & Corner Mantel Cabinet Installation Instructions



## FLAT WALL MANTEL CABINET COMPONENTS:

- 1 Hearth-Base (A)
- 2 Side Sections (B)
- 1 Header (C)
- 1 Cabinet Top (D)
- 1 Opening Trim – Top (E)
- 2 Opening Trim – Sides (F)

## FLAT WALL MANTEL CABINET HARDWARE LIST:

- 12 1 ¼" Screws
- 1 Touch-Up Putty Stick

## CORNER MANTEL CABINET COMPONENTS:

- 1 Hearth-Base (A-1)
- 1 Fireplace Base (A-2)
- 1 Hearth-Base/F.P. Base Assembly Strap (A-3)
- 2 Side Sections (B)
- 1 Header (C)
- 2 Wall Straps (D)
- 1 Cabinet Top – Front (E-1)
- 1 Cabinet Top – Back (E-2)
- 1 Opening Trim – Top (F)
- 2 Opening Trim – Sides (G)

## CORNER MANTEL CABINET HARDWARE LIST:

- 14 1 ¼" Screws
- 4 2 1/2" Screws
- 4 Drywall Anchors

**CAUTION: Read the instructions thoroughly before assembling these products.**

## Description

The Vermont Castings, Majestic Products Flat Wall and Corner cabinets are designed to install around a specified Vermont Castings, Majestic Products fireplace to give a complete and finished look.

Refer to the Table below for fireplace compatibility and dimensions. Use of any appliance other than those manufactured by Vermont Castings, Majestic Products will void any warranties provided by Vermont Castings, Majestic Products.

## Unpack the Mantel

Each Flat Wall Cabinet is composed of a Hearth-Base, Left & Right Side Sections, a Header, 3 Opening Trim mouldings and the Cabinet Top.

Each Corner Cabinet is composed of a Hearth-Base, a fireplace Base extension, Left & Right Side Sections, a Header, Wall Straps, 3 Opening Trim mouldings and a 2-pc Cabinet Top.

Carefully inspect each part for shipping damage before you begin assembly.

Assembly hardware is provided to fasten the Cabinet parts together.

## Mantel Finishes

Each Cabinet is supplied in 3 different finish formats. Oak unfinished, sanded and ready to be stained and/or lacquered. Oak finished, in a light Honey oak stain. Paint Grade, primed and ready for the top coat paint of choice. If the cabinet is to be painted, use only lacquer based paint. Do not use latex base paint.

**CAUTION:** Any other trim or facing that attaches to the fireplace or overlaps the fireplace face, must be of a non-combustible material.

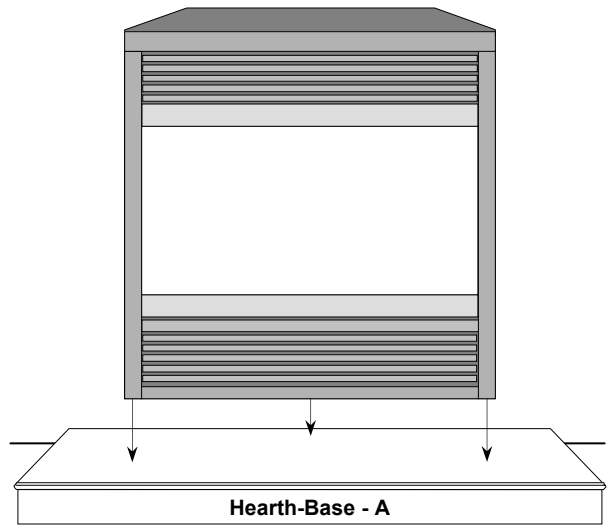
## WALL CABINET ASSEMBLY

(2 people recommended)

**Note:** Before beginning assembly, refer to the instructions in the fireplace owners manual for Electrical &/or Gas Requirements and hook-up. If baseboard is to be removed, it should be done before beginning the assembly process.

- 1) Position the Hearth-Base (A) in the desired location – a few inches out from the wall. Carefully centre the Fireplace on the Hearth-Base - just forward from the back edge.

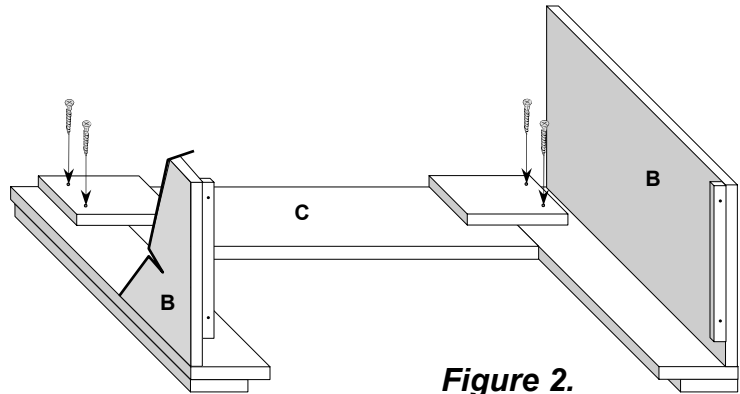
**See Fig. 1**



**Figure 1.**

- 2) Using four 1 ¼" screws attach the Header (C) to the Side Sections (B) through the tabs on the back of the Header at each end.

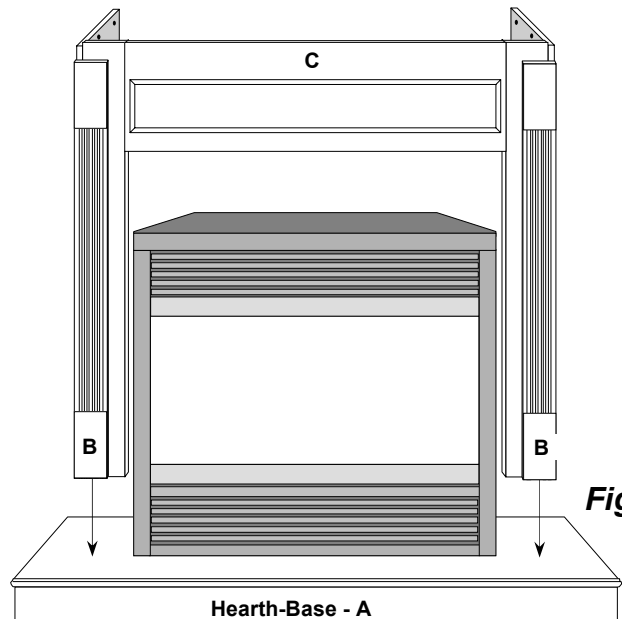
**See Fig. 2**



**Figure 2.**

- 3) Carefully lift the assembled cabinet body onto the Hearth-Base, around the fireplace and behind the fireplace face trim.

**See Fig. 3**

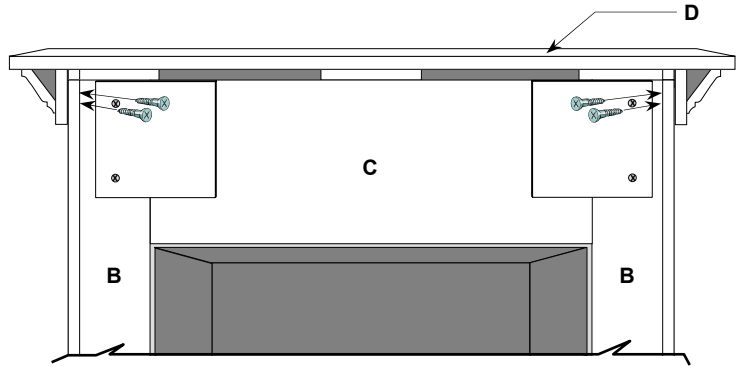


**Figure 3.**

## WALL CABINET ASSEMBLY (cont.)

- 4) Place the Cabinet Top (D) on the assembled cabinet body and align with the back. Attach the top to the cabinet body using 1 ¼" screws, through the pre-drilled pilot holes at the top of each Side Section (B) and the Header (C). Carefully move the Hearth-Base with the fireplace and assembled cabinet body tight against the wall – or baseboard if not removed.

**See Fig. 4**



**Figure 4.**

- 5) **Finish Trim Moulding:**

The finish moulding or trim is used to attach flush to the fireplace top and sides, eliminating any gaps between the fireplace and cabinet. The wood finish moulding should **never** cover the front face of the fireplace.

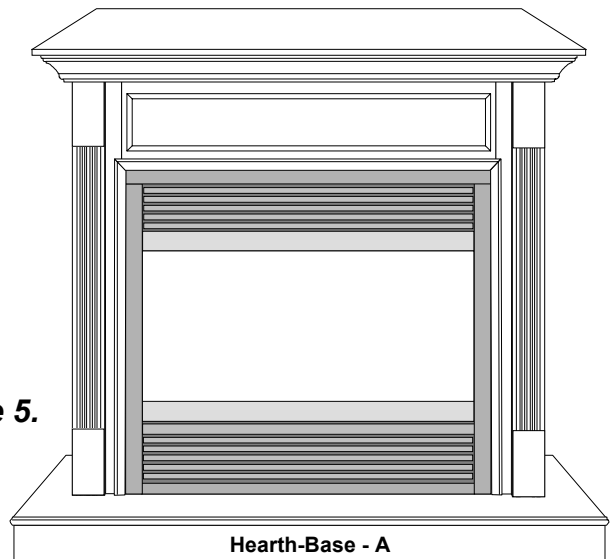
Wood finish moulding is provided for the following Majestic Fireplaces: DVR33, DEF33, 33DVBR, UVS33 DVRT36, DEF36, 36BDVR, 36BDVT, UVC36, UVS36 and DV360.

Optional fireplace trim kits can be used instead of wood finish moulding on these models

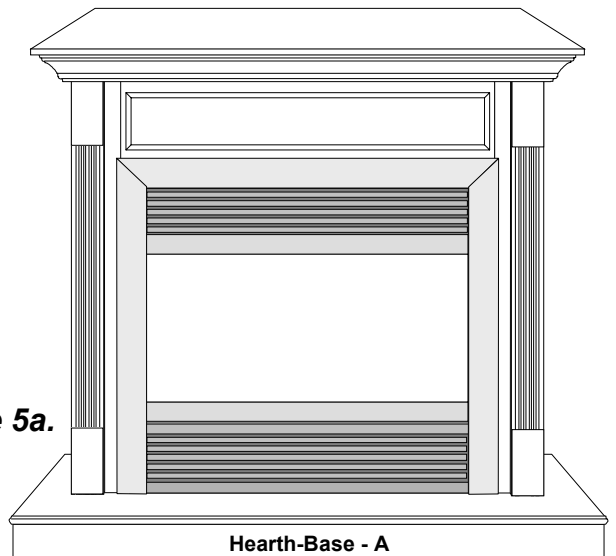
Black finish trims are provided with the cabinet for the UVBR/C36 Majestic Fireplaces.

**See Fig. 5 & 5a**

**Figure 5.**

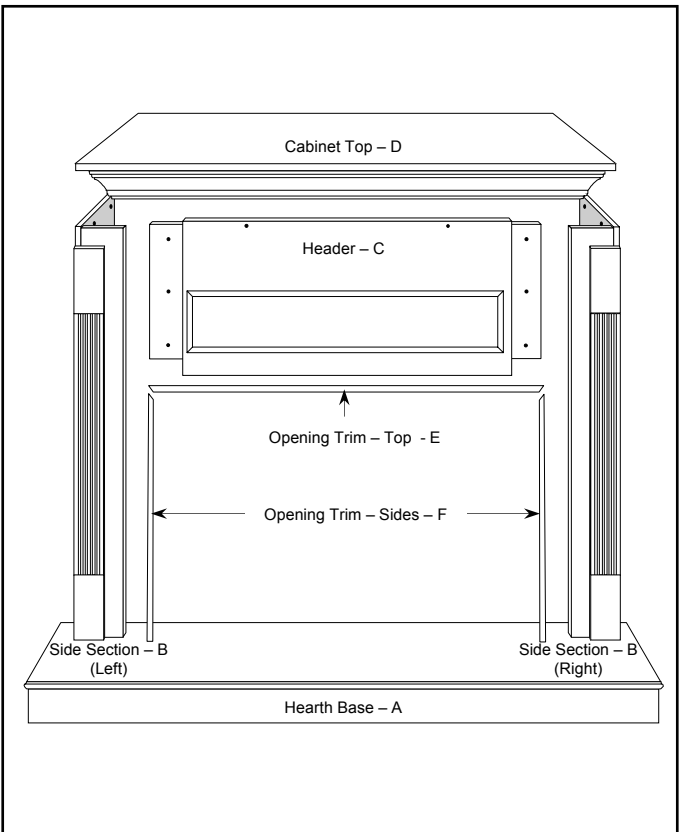


**Figure 5a.**



# Replacement Parts

MODEL	PART NO.	CODE	DESCRIPTION	QTY
FW1033	70000509	A	HEARTH BASE	1
	70000510	B	SIDE SECTION (L)	1
	70000511	B	SIDE SECTION (R)	1
	70000512	C	HEADER	1
	70000513	D	CABINET TOP	1
	70000514	E / F / F	OPENING TRIM	3
	70000656		HARDWARE KIT	1
FW1036	70000527	A	HEARTH BASE	1
	70000528	B	SIDE SECTION (L)	1
	70000529	B	SIDE SECTION (R)	1
	70000530	C	HEADER	1
	70000531	D	CABINET TOP	1
	70000532	E / F / F	OPENING TRIM	3
	70000657		HARDWARE KIT	1
FW1060	70000563	A	HEARTH BASE	1
	70000564	B	SIDE SECTION (L)	1
	70000565	B	SIDE SECTION (R)	1
	70000566	C	HEADER	1
	70000567	D	CABINET TOP	1
	70000568	E / F / F	OPENING TRIM	3
	70000658		HARDWARE KIT	1
FW1H33	70000515	A	HEARTH BASE	1
	70000516	B	SIDE SECTION (L)	1
	70000517	B	SIDE SECTION (R)	1
	70000518	C	HEADER	1
	70000519	D	CABINET TOP	1
	70000520	E / F / F	OPENING TRIM	3
	70000659		HARDWARE KIT	1
FW1H36	70000533	A	HEARTH BASE	1
	70000534	B	SIDE SECTION (L)	1
	70000535	B	SIDE SECTION (R)	1
	70000536	C	HEADER	1
	70000537	D	CABINET TOP	1
	70000538	E / F / F	OPENING TRIM	3
	70000660		HARDWARE KIT	1
FW1H60	70000569	A	HEARTH BASE	1
	70000570	B	SIDE SECTION (L)	1
	70000571	B	SIDE SECTION (R)	1
	70000572	C	HEADER	1
	70000573	D	CABINET TOP	1
	70000574	E / F / F	OPENING TRIM	3
	70000661		HARDWARE KIT	1
FW1U06	70000545	A	HEARTH BASE	1
	70000546	B	SIDE SECTION (L)	1
	70000547	B	SIDE SECTION (R)	1
	70000548	C	HEADER	1
	70000549	D	CABINET TOP	1
	20006858	E / F / F	OPENING TRIM (STEEL)	3
	70000662		HARDWARE KIT	1
FW1UH6	70000551	A	HEARTH BASE	1
	70000552	B	SIDE SECTION (L)	1
	70000553	B	SIDE SECTION (R)	1
	70000554	C	HEADER	1
	70000555	D	CABINET TOP	1
	20006858	E / F / F	OPENING TRIM (STEEL)	3
	70000663		HARDWARE KIT	1



MODEL	PART NO.	CODE	DESCRIPTION	QTY
FW1UW6	70000557	A	HEARTH BASE	1
	70000558	B	SIDE SECTION (L)	1
	70000559	B	SIDE SECTION (R)	1
	70000560	C	HEADER	1
	70000561	D	CABINET TOP	1
	20006858	E / F / F	OPENING TRIM (STEEL)	3
	70000664		HARDWARE KIT	1
FW1W33	70000521	A	HEARTH BASE	1
	70000522	B	SIDE SECTION (L)	1
	70000523	B	SIDE SECTION (R)	1
	70000524	C	HEADER	1
	70000525	D	CABINET TOP	1
	70000526	E / F / F	OPENING TRIM	3
	70000665		HARDWARE KIT	1
FW1W36	70000539	A	HEARTH BASE	1
	70000540	B	SIDE SECTION (L)	1
	70000541	B	SIDE SECTION (R)	1
	70000542	C	HEADER	1
	70000543	D	CABINET TOP	1
	70000544	E / F / F	OPENING TRIM	3
	70000666		HARDWARE KIT	1
FW1W60	70000575	A	HEARTH BASE	1
	70000576	B	SIDE SECTION (L)	1
	70000577	B	SIDE SECTION (R)	1
	70000578	C	HEADER	1
	70000579	D	CABINET TOP	1
	70000580	E / F / F	OPENING TRIM	3
	70000667		HARDWARE KIT	1

## **CORNER CABINET ASSEMBLY**

(2 people recommended)

**Note:** Before beginning assembly, refer to the instructions in the fireplace owners manual for Electrical &/or Gas Requirements and hook-up. If baseboard is to be removed, it should be done before beginning the assembly process.

- 1) Using the 1 ¼" screws provided, attach the F.P. Base (A-2) to the Hearth-Base (A-1). Position in the desired corner location. Fasten the Wall Straps (D) to the wall using the 2 ½" screws. Drywall anchors are provided if necessary. The top edge of the Wall Straps should be aligned with the top edge of the Side Sections when placed on top of the Hearth-Base (A).

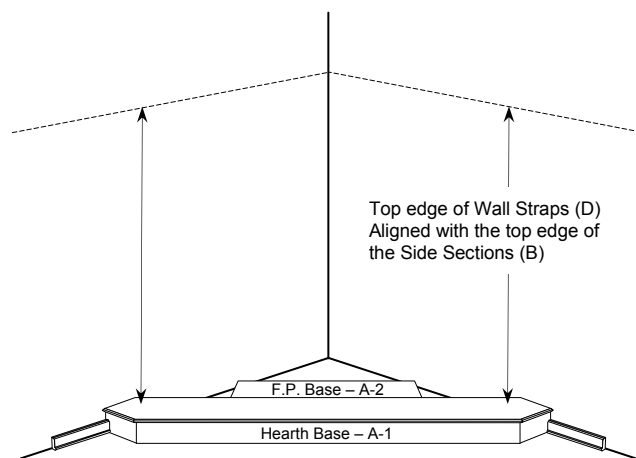
**See Fig. 1**

- 2) Carefully centre the Fireplace on the Hearth-Base - just forward from the back edge. Final positioning of the fireplace will take place once the cabinet has been put into place.

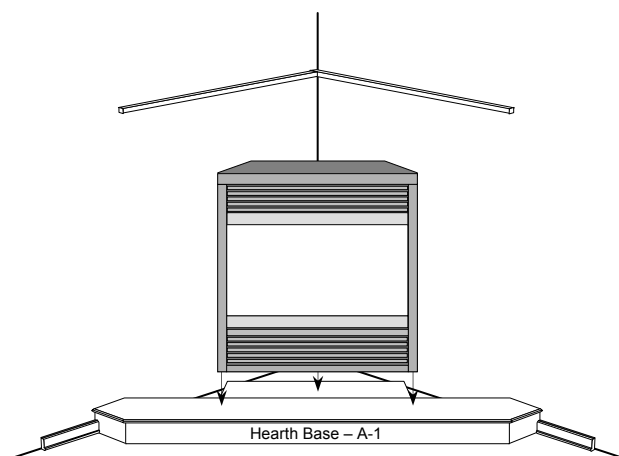
**See Fig. 2**

- 3) Lay the 2 Side Sections (B) and the Header (C) face down on a clean surface. Using the 1 ¼" screws provided fasten the Header to the Side Sections through the holes drilled in the tabs attached to the back of the Header.

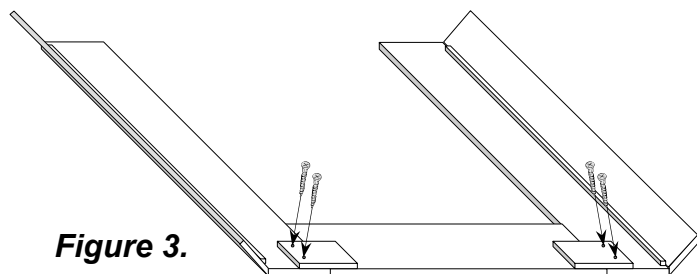
**See Fig. 3**



**Figure 1.**



**Figure 2.**

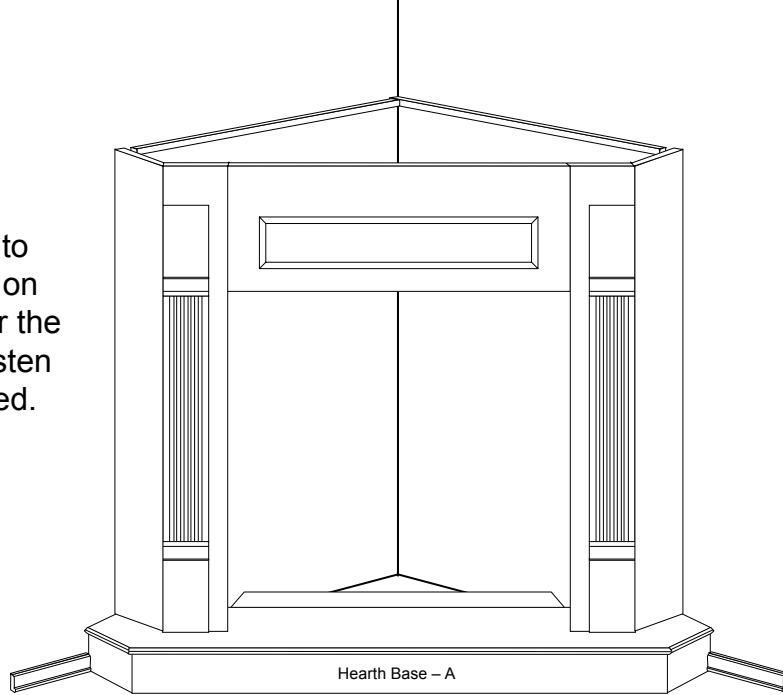


**Figure 3.**

## CORNER CABINET ASSEMBLY

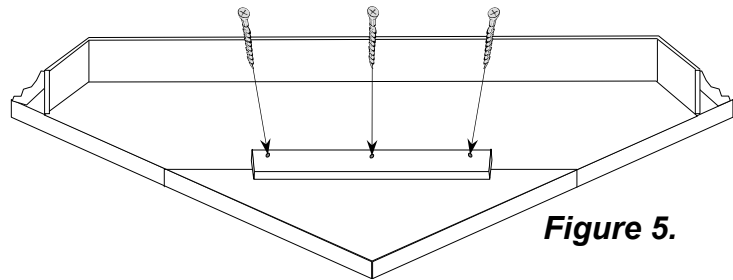
(cont.)

- 4) Carefully lift the assembled cabinet onto the Hearth-Base (A), fitting the blocks on the back of each Side Section (B) over the threaded rod in the Hearth-Base. Fasten with the washers and wingnuts provided. **See Fig. 4**



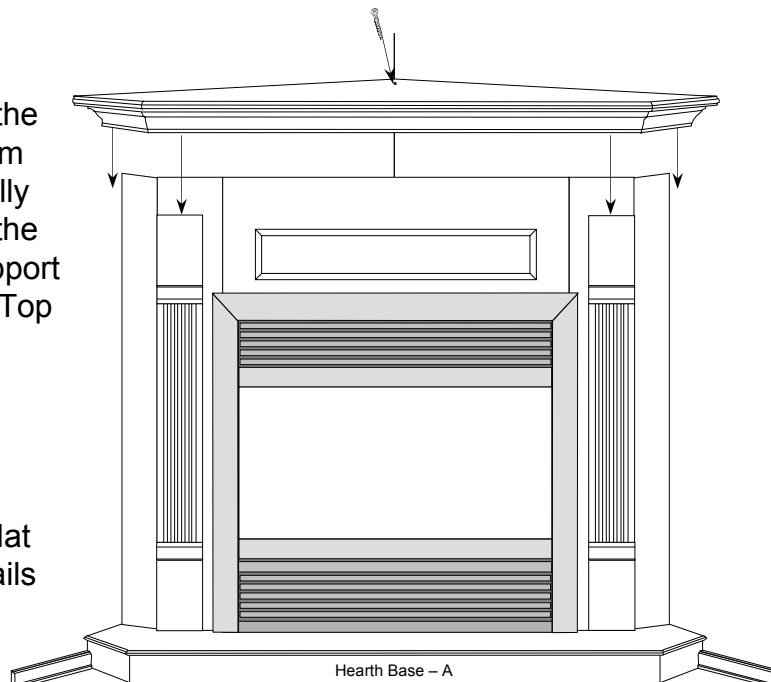
**Figure 4.**

- 5) Lay the 2 Top Shelf sections (E-1 & E-2) face down on a clean surface. Align the pieces and fasten through the tab on the back of E-1, using the 1 ¼" screws provided. **See Fig. 5**



**Figure 5.**

- 6) Insert the fireplace into the opening of the cabinet and centre with the fireplace trim against the face of the cabinet. Carefully place the assembled Top Shelf (E) on the cabinet body. Fasten to the corner support (D) through the hole at the back of the Top Shelf, using the 1 ¼" screw provided. **See Fig. 6**

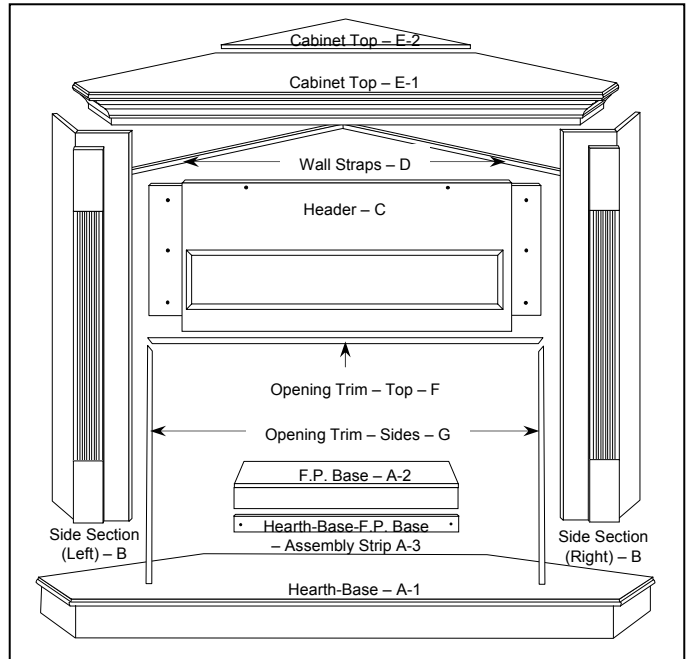


**Figure 6.**

**Finish Trim Moulding:** See Step 5 in the Flat Wall Cabinet Assembly section for details on trim options.

# Replacement Parts

MODEL	PART NO.	CODE	DESCRIPTION	QTY
FC1033	70000581	A-1	HEARTH BASE	1
	70000582	A-2	FIREPLACE BASE	1
	70000583	A-3	ASSEMBLY STRIP - (HEARTH/F.P.BASE)	1
	70000584	B	SIDE SECTION (LEFT)	1
	70000585	B	SIDE SECTION (RIGHT)	1
	70000586	C	HEADER	1
	70000587	D	WALL STRAPS	2
	70000588	E-1	CABINET TOP - FRONT SECTION	1
	70000589	E-2	CABINET TOP - BACK	1
	70000590	F / G / G	OPENING TRIM	1
	70000650		HARDWARE KIT	1
FC1036	70000611	A-1	HEARTH BASE	1
	70000612	A-2	FIREPLACE BASE	1
	70000613	A-3	ASSEMBLY STRIP - (HEARTH/F.P.BASE)	1
	70000614	B	SIDE SECTION (L)	1
	70000615	B	SIDE SECTION (R)	1
	70000616	C	HEADER	1
	70000617	D	WALL STRAPS	2
	70000618	E-1	CABINET TOP - FRONT SECTION	1
	70000619	E-2	CABINET TOP - BACK	1
	70000620	F / G / G	OPENING TRIM	1
	70000651		HARDWARE KIT	1
FC1H33	70000591	A-1	HEARTH BASE	1
	70000592	A-2	FIREPLACE BASE	1
	70000593	A-3	ASSEMBLY STRIP - (HEARTH/F.P.BASE)	1
	70000594	B	SIDE SECTION (L)	1
	70000595	B	SIDE SECTION (R)	1
	70000596	C	HEADER	1
	70000597	D	WALL STRAPS	2
	70000598	E-1	CABINET TOP - FRONT SECTION	1
	70000599	E-2	CABINET TOP - BACK	1
	70000600	F / G / G	OPENING TRIM	1
	70000652		HARDWARE KIT	1
FC1H36	70000621	A-1	HEARTH BASE	1
	70000622	A-2	FIREPLACE BASE	1
	70000623	A-3	ASSEMBLY STRIP - (HEARTH/F.P.BASE)	1
	70000624	B	SIDE SECTION (L)	1
	70000625	B	SIDE SECTION (R)	1
	70000626	C	HEADER	1
	70000627	D	WALL STRAPS	2
	70000628	E-1	CABINET TOP - FRONT SECTION	1
	70000629	E-2	CABINET TOP - BACK	1
	70000630	F / G / G	OPENING TRIM	1
	70000653		HARDWARE KIT	1



MODEL	PART NO.	CODE	DESCRIPTION	QTY
FC1W33	70000601	A-1	HEARTH BASE	1
	70000602	A-2	FIREPLACE BASE	1
	70000603	A-3	ASSEMBLY STRIP - (HEARTH/F.P.BASE)	1
	70000604	B	SIDE SECTION (L)	1
	70000605	B	SIDE SECTION (R)	1
	70000606	C	HEADER	1
	70000607	D	WALL STRAPS	2
	70000608	E-1	CABINET TOP - FRONT SECTION	1
	70000609	E-2	CABINET TOP - BACK	1
	70000610	F / G / G	OPENING TRIM	1
	70000654		HARDWARE KIT	1
FC1W36	70000631	A-1	HEARTH BASE	1
	70000632	A-2	FIREPLACE BASE	1
	70000633	A-3	ASSEMBLY STRIP - (HEARTH/F.P.BASE)	1
	70000634	B	SIDE SECTION (LEFT)	1
	70000635	B	SIDE SECTION (RIGHT)	1
	70000636	C	HEADER	1
	70000637	D	WALL STRAPS	2
	70000638	E-1	CABINET TOP - FRONT SECTION	1
	70000639	E-2	CABINET TOP - BACK	1
	70000640	F / G / G	OPENING TRIM	1
	70000655		HARDWARE KIT	1

## **Vermont Castings' Cabinet Limited Warranty**

Vermont Castings warrants its cabinet to be free of defects in material and workmanship under normal home use and service for a period of one (1) year from the date of purchase. Vermont Castings' sole obligation during the term of the warranty shall be to repair or arrange to be repaired, or, at Vermont Castings' option, to replace any cabinet parts or components deemed to be defective. Costs covered will include reasonable labour charges, if necessary, for the removal and re-installation of the defective cabinet, part or component and also reasonable freight costs in transporting the defective cabinet, part, or component to an authorized service centre.

### ***Conditions and Exclusions***

Excluded from coverage under the warranty are repairs of damage arising from:

- Transportation or warehousing of cabinets
- Abuse or vandalism
- Any modification of the cabinet in a manner not authorized by Vermont Castings
- Work or services on the cabinet by anyone other than an authorized Vermont Castings dealer or distributor

Vermont Castings is entitled to receive and retain any defective parts or components, which are replaced pursuant to the terms of this warranty. Your Vermont Castings' dealer, or an authorized representative, must carry out repairs or replacements under this warranty or someone authorized by them. The owner must pay for any charges or expenses not covered by this warranty.

Vermont Castings' liability under this warranty shall be limited to the original purchase price of the cabinet.