

Symmons

TEMPTROL® II

BP and 2000 Series Pressure-Balancing Mixing Valve for Shower or Tub/Shower Application

INSTALLATION, OPERATION & SERVICE INSTRUCTIONS



Symmons valves and shower heads comply to all known standards, codes and specifications: CSA B-125, ANSI A112.18.1M, ASSE 1016, EPA '92 etc.

Symmons shower heads are equipped with a 2.5 GPM (9.5 L/min) water and energy saving flow restrictor.

LIFETIME LIMITED WARRANTY

Symmons warrants to the original consumer purchaser that any TEMPTROL® series* or SYMMETRIX® product will be free of defects in material and workmanship during normal domestic use for the life of your home. All other products and purchasers including industrial, commercial or business use are warranted for a period of 5 years from the date of purchase. At our option, we will either have you send the defective part or product prepaid to us for inspection, or we may elect to send you the replacement part or product without investigation. A replacement for any defective part will be supplied FREE OF CHARGE for installation by the purchaser. Defect or damage caused by the use of replacement parts other than Symmons Genuine Replacement Parts will void this warranty. This warranty excludes product damage due to installation error, product abuse, or product misuse whether performed by a contractor, service company or yourself. Symmons further warrants that any TEMPTROL or SYMMETRIX product will be leak free and drip free during normal domestic use for the life of your home. If the product should develop a leak or drip, Symmons will provide FREE OF CHARGE the parts necessary to return it to good working condition. Proof of purchase (original sales receipt) and a copy of the warranty registration card from the original consumer purchaser must accompany all warranty claims. This warranty is applicable only to Symmons TEMPTROL or SYMMETRIX products purchased after July 1, 1998 and shall be effective from the date of purchase as shown on the purchaser's receipt. Damage to the chrome and/or other decorative finishes on Symmons products may be a result of improper handling or abusive treatment. Finishes should only be cleaned with a soft, damp cloth or sponge. Use of polish, abrasive cleaners, solvents, or acid cleaners will damage the finish and void this warranty. There are no other express warranties on this product and ALL WARRANTIES OF MERCHANTABILITY AND OTHER IMPLIED WARRANTIES ARE LIMITED IN ACCORDANCE WITH APPLICABLE LAW. SYMMONS INDUSTRIES, INC., EXPRESSLY DISCLAIMS CONTINGENT LIABILITY AND CONSEQUENTIAL DAMAGE OF EVERY KIND. Since some states do not allow limitations on how long an implied warranty lasts or an exclusion or limitation of incidental or consequential damages the above limitation or exclusion may not be applicable. This warranty gives specific legal rights. Other rights may vary from state to state. To obtain warranty service, write to Symmons Industries, Inc., 31 Brooks Drive, Braintree, MA 02184-3804 or call our Customer Service Department at 1-800-SYMMONS. If writing to us, please include proof of purchase, the model number of the product with a brief description of the problem, your name, address and phone number.

*Temptrol series includes Allura®, Olde Braintree Brass®, Temptrol, Temptrol Deluxe and Temptrol II shower and tub/shower systems.

IMPORTANT: After completion of installation step 4, follow these instructions to set the Temptrol II Limit Stop Screw. This valve is equipped with a limit stop screw to be used to limit valve handle from being turned to excessively hot water discharge temperatures. To adjust, remove dome cover, open valve to maximum desired temperature and turn in limit stop screw until it seats.

WARNING: FAILURE TO ADJUST THE LIMIT STOP SCREW PROPERLY MAY RESULT IN SERIOUS SCALDING.

WARNING: THIS SHOWER SYSTEM MAY NOT PROTECT THE USER FROM SCALDING WHEN THERE IS A FAILURE OF OTHER TEMPERATURE CONTROLLING DEVICES ELSEWHERE IN THE PLUMBING SYSTEM.



For ADA compliance (Americans with Disabilities Act) consult ADAAG or your state regulations for proper product choice and mounting locations.

PLEASE READ ALL INSTRUCTIONS CAREFULLY BEFORE STARTING INSTALLATION. SAVE THIS MANUAL FOR FUTURE REFERENCE.



INSTALLATION OF: SHOWER SYSTEMS AND TUB/SHOWER SYSTEMS

Tools required for installation of this product are: Phillips screw driver, tubing cutter, teflon tape, soldering equipment, adjustable wrench and channelHock pliers.

1. Install piping and fittings with valve body as shown in Figure 2 or 3. **IMPORTANT: Valve rough-in is 2-3/8" +/- 1/2" from CENTERLINE OF SUPPLIES TO FACE OF FINISH WALL.** Install so that line indicated on rough-in plaster shield (T-176) on valve is flush with finish wall as shown in Figure 1 (See Figure 5 for fiberglass wall installation).

FIGURE 1

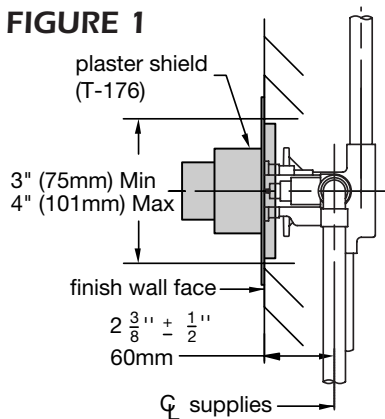

Tub/Shower System (Figure 2) Model BP-56-2, 25-2

Pipe shower head from outlet marked "S" and to tub spout from outlet marked "T". The valve in this system has a built-in choke for use with a diverter spout. The built-in choke is designed so that it cannot be subject to any back pressure, other than is imposed by the spout supplied with this package. **DO NOT SUBSTITUTE OTHER OUTLET ACCESSORIES FOR THE TUB SPOUT (SUCH AS HOSE AND SPRAY, SHOWER HEAD, BODY SPRAY, LEDGE SPOUTS, ETC.) OR ANY PIPE ADAPTER OR ADDITIONAL FITTINGS (SUCH AS PEX, ETC.) THAT CAN CAUSE BACK PRESSURE THROUGH THE VALVE.** Install HOT on left and COLD on right according to valve markings.

Tub or Shower System (Figure 3) Model BP-56-1, 25-1

Shower System: Pipe shower head from outlet marked "S". Install either the included copper sweat or 1/2"-14 NPT plug (pipe sealer required) into the outlet marked "T" (see figure 3A).

Tub only System: Pipe tub spout from outlet marked "T". Install either the included copper sweat or 1/2"-14 NPT plug (pipe sealer required) into the outlet marked "S" (figure 3A).

FIGURE 2
Model A: Tub/Shower System (BP-56-2 Shown)

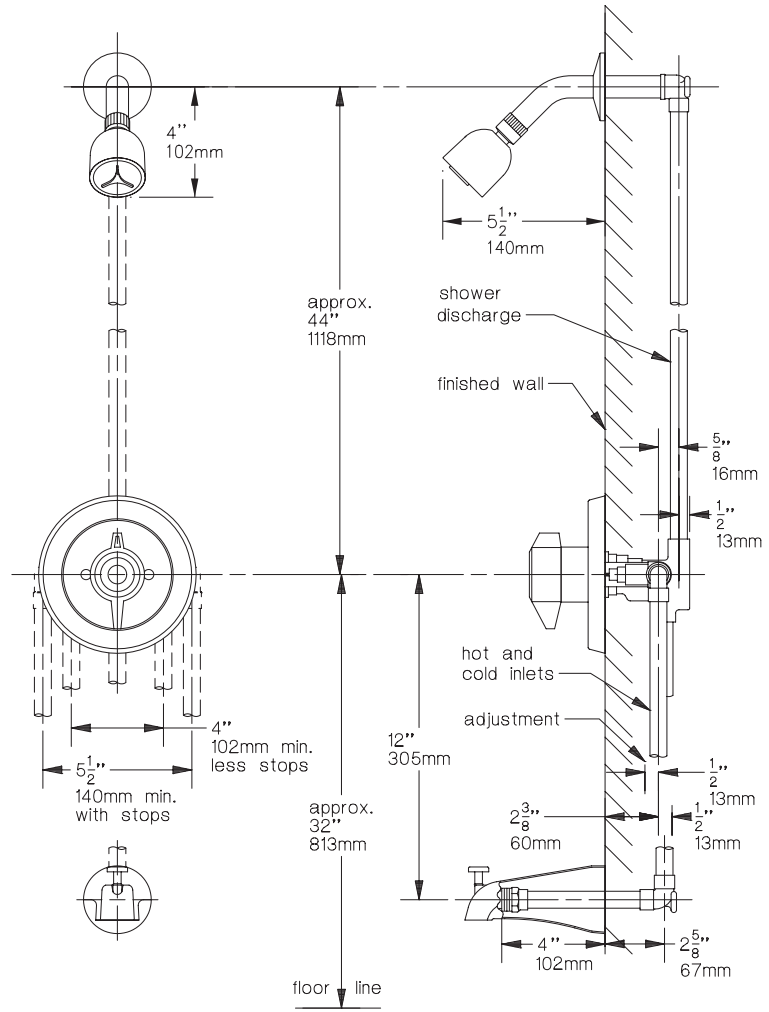

Suffix SS: Slip-on type spout

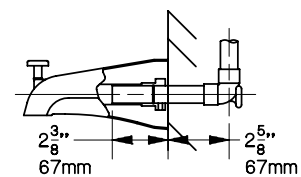

2. When finishing tile wall PULL OFF ENTIRE PROTECTIVE PLASTER SHIELD (T-176). If finish wall obstructs removal of plaster shield, break off outer edge along perforations (if necessary, carefully use sharp blade to facilitate removal). After plaster shield is removed FILL AREA AROUND VALVE BODY WITH GROUT OR PLASTER
3. TURN ON HOT AND COLD SUPPLIES, valve will not operate unless both hot and cold water are turned on.
4. Unscrew dome cover (T-19/20) and tighten packing nut (T-17) for positive frictional resistance to handle turn throughout adjustment cycle and at shut-off position. Check valve cap, packing nut, diverter spindle o-ring and all valve, pipe and fitting connections for leaks.
5. SET LIMIT STOP SCREW AS DIRECTED AFTER "IMPORTANT" IN BOLD TYPE ON PAGE ONE. Reattach dome cover back onto packing nut.
6. Mount gasket (T-27B), T3-27B onto back of escutcheon with opening at bottom as shown in Figure 4. The use of this gasket should not preclude sealing valve body in wall as directed in installation instruction step #2.
7. ALLOW VALVE TO RUN IN WARM

FIGURE 4

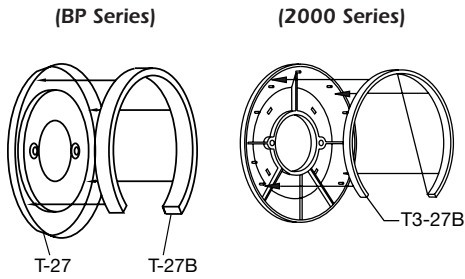

POSITION FOR A FEW MINUTES TO TOTALLY FLUSH SYSTEM. IF SYSTEM IS QUITE DIRTY, REMOVE VALVE SPINDLE OR STOP SPINDLES (IF SO EQUIPPED) TO INSURE PROPER FLUSHING. See service instructions.

8. BP Series

Push escutcheon (T-27) with dial plate (T-29CT2) against wall and secure to valve with two escutcheon screws (T-28).

2000 Series

Push escutcheon (T-27) against wall and secure to valve with two escutcheon screws (T-28). Snap dial emblem assembly (T-3-29) onto escutcheon by engaging tabs on dial into the mating recesses in escutcheon.

Mount temperature control handle on valve spindle spline as shown in figure 9. Install shower arm, flange and shower head. See Figures 2 and 3.

9. Do not install positive shut-off devices on the outlet of this valve or devices that do not allow the valve to flow at least 1 GPM at 50 psi inlet pressure. EXCEPTION: If a self-closing or slow-closing valve is installed on the outlet, the supplies of the valve must be equipped with checks to eliminate hot to cold by-pass in the event the valve's handle is not turned to off after use. Contact your factory representative or Symmons directly for information on available checks.

FIBERGLASS WALL INSTALLATION

When installing Tempetro® II series valves in fiberglass or panel walls and it is desired to sandwich wall between valve body and escutcheon, cut hole in wall as shown in Figure 5 and mount valve with T-177 wall mounting flange from rear. **Note: It is always recommended to secure valve piping to rough construction and not depend on fiberglass wall for valve mounting security.** On panel walls over 1" thick, install in conventional manner.

**FIGURE 3
Model B: Shower System (25-1 Shown)**

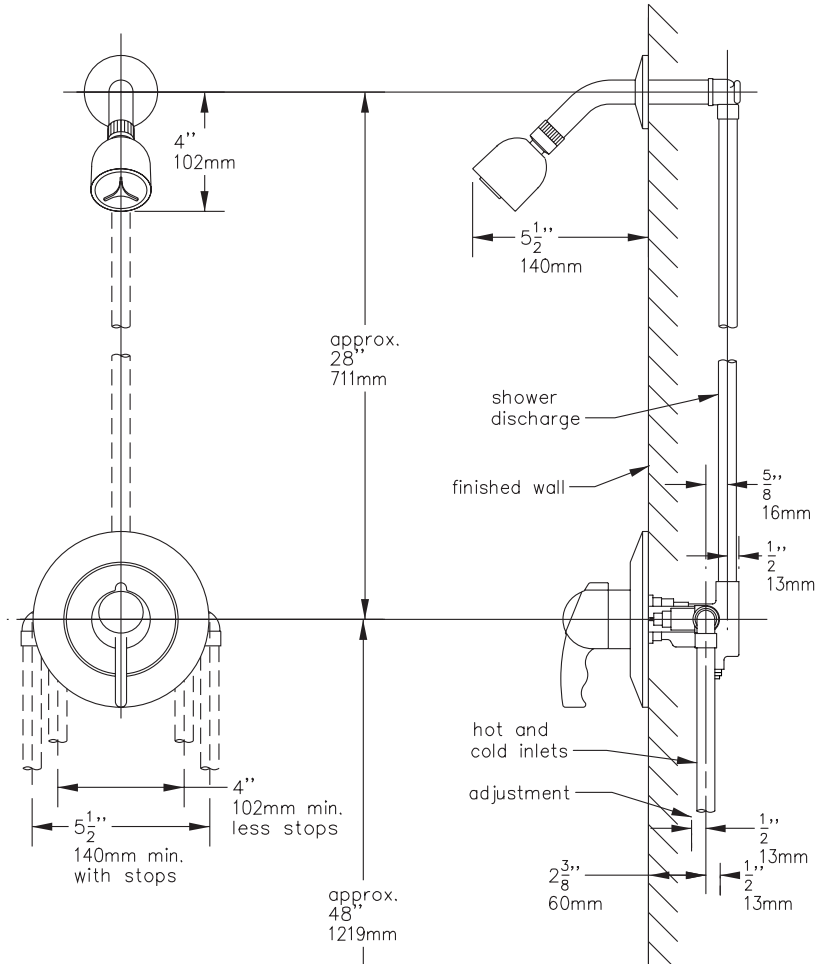

FIGURE 3A

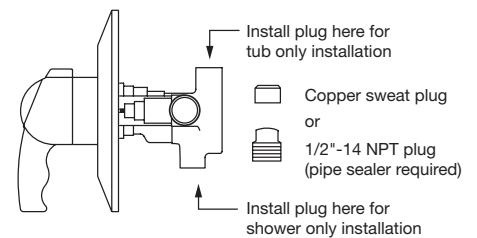
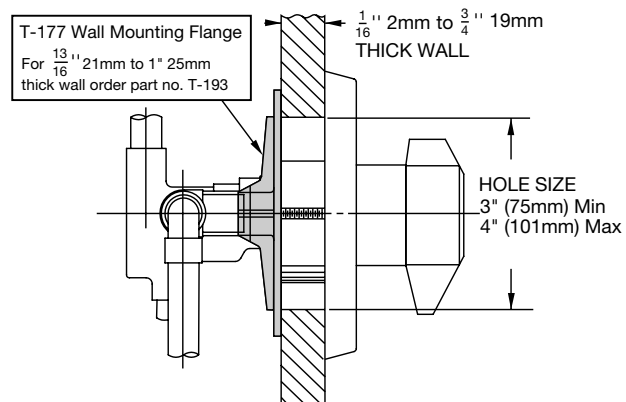

FIGURE 5



BACK TO BACK INSTALLATION

To simplify piping on back to back installations use one standard valve (hot on left, cold on right) and one with reverse coring (hot on right, cold on left) as shown in Figure 6 and 7. Order reverse core valve **by adding the suffix REV-X** after the plate number. (e.g. BP-56-2-REV-X Temptrol® II tub and shower unit with reverse coring.)

FIGURE 6

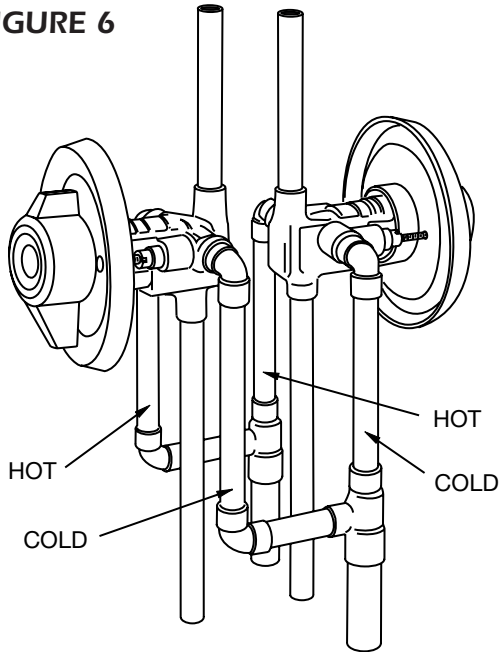
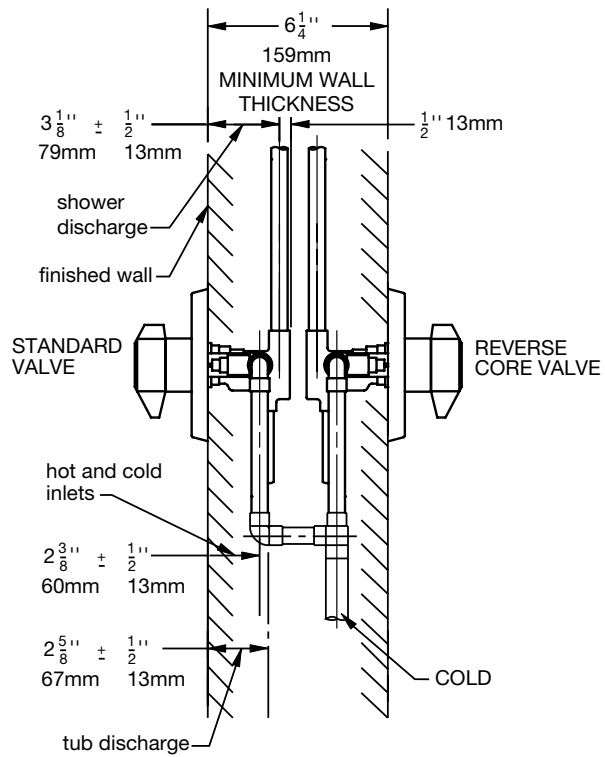

FIGURE 7
Back to Back Installation



OPERATION OF VALVE

The main handle of a Temptrol® II series valve is for control of temperature only. From the OFF position, the handle is turned counter-clockwise through a minimum cold position, through a warm and hot position for a maximum turn of approximately one revolution. This allows for wide range of temperature adjustments to suit the requirements of any user.

CARE AND CLEANING

The lustrous finish on your Temptrol II series valve should be treated with care. It can be readily damaged by improper handling or abusive treatment. To clean the finish wipe gently with a soft damp cloth and blot dry with a soft towel. Use only a mild soap solution if required. **DO NOT USE ABRASIVE CLEANERS. USE OF POLISH, ABRASIVE CLEANERS, SOLVENTS OR ACID CLEANERS WILL DAMAGE THE FINISH AND VOID THE SYMMONS WARRANTY.**

FIGURE 8
Seat Removal Tools

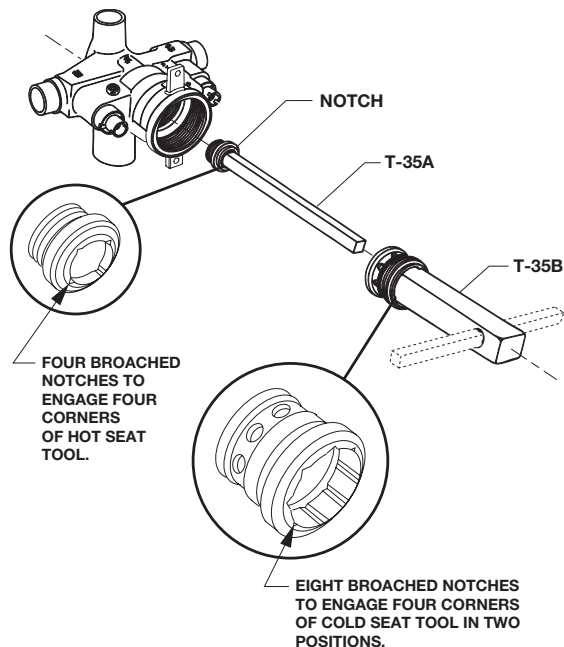

SERVICE

1. Shut off water supply to valve.
2. Remove handle plug button and handle (see figure 9).
3. **BP Series** Remove dial (T-29CT2) and escutcheon (T-27) by removing escutcheon screws (T-28). Remove all remaining trim.
2000 Series Remove dial (T3-29) by prying up from the slot located at 6 o'clock and then pry up around the clock until dial is loose. Remove escutcheon T3-27(D) by removing escutcheon screws (T3-28). Remove all remaining trim.
4. Open valve to about warm position and unscrew cap (T-12A). Warning: Failure to do this will damage cap and spindle. Spindle assembly (TA-10) will be removed with cap. Leave packing nut (T-17) in place while unscrewing cap to avoid distortion.
5. Ordinary service to eliminate dripping or not shutting off requires only the replacement of parts supplied in washer and gasket kit (TA-9). Hold spindle with handle while removing hot washer screw and cold washer retainer (remove retainer with channel lock pliers).
6. Inspect top surfaces of hot and cold seats and replace if necessary. Important: When replacing hot and cold seats, always replace both seats. Even if only one seat appears worn, both seats must be replaced. Use part No. (TA-4). After long years of service, if spindle is very loose in cold seat, replace with part no. (TA-4). Use seat removal tool [T-35(A,B)] for removal and replacement of (TA-4). If seats are difficult to remove and tool shifts damaging notches, relocate tool in second position of notches. Tighten both seats to 15 foot pounds of torque.
7. The perforated end of the (TA-10) spindle assembly houses the balancing piston which is the heart of this pressure balancing valve. The piston should be free to move back and forth and should click when the spindle assembly is shaken. If deposits block this action, tap the handle end of the spindle against a solid object to free the piston. Soaking in household vinegar will help free foreign matter. If this does not free piston, replace (TA-10) spindle assembly. **Do not tamper with perforated cylinder on the spindle assembly or attempt removal of the piston.**
8. Reassemble, reversing above procedure, be sure spindle assembly is drawn close to the cap before screwing cap back into valve. Warning: Failure to do this will damage cap and spindle.
9. Use only Symmons Genuine Repair Parts. Failure to do so will void all warranties AND IMPAIR PROPER OPERATION OF YOUR VALVE.

TROUBLE SHOOTING CHART

Problem	Cause	Solution (Follow service instructions)
Valve will not pass water.	Hot and cold water not turned on.	Turn on both supplies. Valve will not operate unless both HOT and COLD water pressure is turned on.
Valve leaks when shut off.	Hot and cold washers are worn, or foreign matter (solder, chips, etc.) are between washers and seat surfaces	Replace Hot and Cold washers, inspect top surface on hot and cold seats and replace if necessary.
Temperature control handle is turned from cold to hot (or hot back to cold) and volume from spout or head is not constant.	Pressure balancing piston housed in spindle assembly is blocked from free movement by foreign matter.	With valve open half way, remove handle and tap spindle with plastic hammer. If problem not solved, remove spindle assembly completely and tap handle against solid object to free piston. Soaking in household vinegar will help free foreign matter.
Valve delivers sufficient quantity of cold, but little hot, or the reverse of this.	Same as above	Same as above
Temperature varies without moving handle.	Same as above	Same as above
Valve delivery temperature reduces gradually during use; must be turned on to hotter positions to maintain constant temperature.	Overdraw on hot water supply, i.e., running out of hot water.	Reduce maximum flow by using volume control adjustment on valve or shower head. This will allow longer period of use before overdrawing hot water supply.
Valve delivers hot water when initially opened and water turns colder when the handle is rotated in a counter-clockwise direction.	Valve is piped incorrectly, i.e., the hot supply is piped to the cold inlet to the valve and the cold supply is piped to the hot inlet of the valve.	If piping is accessible, correct piping connections to the valve. If piping is not accessible, contact factory to order a reverse seat and tool (T-108 KIT). Older installations may require replacement of the hot seat (T-1) as well

SYMMONS INDUSTRIES, INC.

31 Brooks Drive, Braintree, MA 02184-3804

TEL: 1-800-SYMMONS, (781) 848-2250 FAX: 1-800-961-9621, (781) 843-3849

Website: www.symmons.com

© 1997-2007 Symmons Industries, Inc. Printed in U.S.A. 032107 2.5M

ZV-123 3 HOLE

