

**SPORTCRAFT** 

# Billiard Table

**ASSEMBLY, INSTRUCTIONS AND RULES**

**1-1-32-018DS MC**

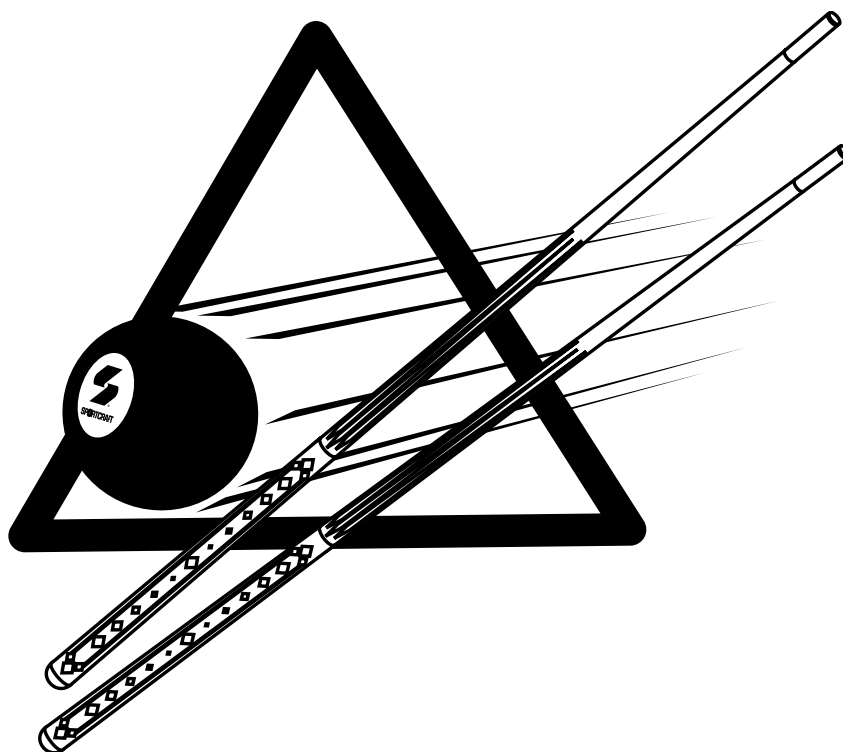

**For Replacement Parts (24hrs / 7days)**

order direct at [www.sportcraft.com](http://www.sportcraft.com),

or call our

Express Parts Center (866) 206-4321

**For Technical Support (9:00am to 5:00pm EST) call**

Sportcraft Consumer Service at (800) 526-0244

# MODEL # 1-1-32-018DS MC

**Congratulations on owning a new Sportcraft Billiard Table! We at Sportcraft hope you will have many hours of enjoyable use with this product.**

**WARNING:** Choking Hazard -- Table contains small balls and/or small parts. Not for children under 3 years.

## IMPORTANT!











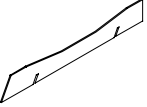
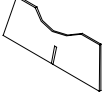



**Please Keep Your Instructions!** Your Model number is necessary should you need to contact us. Please read through this instruction book to familiarize yourself with all the parts and assembly steps. Kindly refer to the Parts Identifier below and be sure that all parts have been included. Although we at Sportcraft are dedicated to giving our customers the best product possible, a question may arise or a part may be missing. Don't return the game to the store.

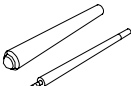



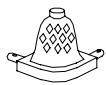





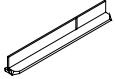
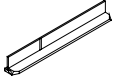
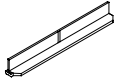

**For Replacement Parts (24hrs / 7days)**  
 order direct at [www.sportcraft.com](http://www.sportcraft.com),  
 or call our Express Parts Center (866) 206-4321  
**For Technical Support (9:00am to 5:00pm EST)** call  
 Sportcraft Consumer Service at (800) 526-0244

**TOOLS REQUIRED FOR ASSEMBLY:**

- Phillips and Slotted Head Screwdrivers (or Power Driver) - not included
- Allen Key and Metal Wrench- included
- Level (recommended) - not included

## PARTS IDENTIFIER

1  SIDE PANEL 9-3-32-018MC01 (2)	2  END PANEL 9-3-32-018MC02 (2)	3  5" LEG LEVELER 9-3-52-085MC02 (4)	4  V- BRACKET 9-3-32-018MC03 (4)	5  L - BRACKET 9-3-32-08MC04 (4)
6 (PRE-INSTALLED)  X - BRACKET 9-3-32-018MC05 (2)	7  WOODEN PIECE 9-3-32-018MC06 (4)	8  2 PC 57" BILLIARD CUE 9-3-52-085MC06 (2)	9  2-1/4" BILLIARD BALL SET 9-3-52-085MC07 (1)	10  TRIANGLE 9-3-52-085MC08 (1)
11  CHALK 9-3-52-085MC09 (2)	12 (PRE-INSTALLED)  BILLIARD CORNER POCKET 9-3-32-018MC07 (4)	13 (PRE-INSTALLED)  BILLIARD SIDE POCKET 9-3-32-018MC08 (2)	14 (PRE-INSTALLED)  BARREL NUT 9-3-32-018MC20 (6)	15 (PRE-INSTALLED)  4 X 45 MM WASHER HEAD SCREW 9-3-34-418MC07 (6)

16 (PRE-INSTALLED)  RIGHT SIDE TOP RAIL 9-3-32-018MC11 (2)	17 (PRE-INSTALLED)  LEFT SIDE TOP RAIL 9-3-32-018MC12 (2)	18 (PRE-INSTALLED)  END TOP RAIL 9-3-32-018MC13 (2)	19  TABLE LEG 9-3-32-018MC14 (4)	20 (PRE-INSTALLED)  8 X 25MM ALLEN KEY BOLT 9-3-32-018MC15 (2)
21  9 X 25MM ALLEN KEY BOLT 9-3-32-018MC16 (16)	22 (PRE-INSTALLED)  5 X 36MM WASHER HEAD SCREW 9-3-32-018MC17 (18)	23 (PRE-INSTALLED)  3 X 12MM ROUND HEAD SCREW 9-3-34-514MC46 (24)	24  4 X 12MM FLAT HEAD SCREW 9-3-32-018MC18 (76)	25  4.3 x 20MM FLAT HEAD SCREW 9-3-32-018MC19 (16)
26  5MM ALLEN KEY 9-3-34-514MC54 (1)	27 (PRE-INSTALLED)  CUE TIPS 9-3-32-018MC23 (2)	28 (PRE-INSTALLED)  NAME PLATE 9-3-34-514MC52 (2)	29  K - BRACKET 9-3-32-018MC21 (6)	30  25MM WASHER 9-3-32-018MC22 (16)

### **ASSEMBLY INSTRUCTIONS:**

**We recommend that two adults work together to assemble this game.**

- 1) Open the carton of your new Billiard Table near where you will play. Select a clear, level area. The table will be assembled upside down and then turned over onto its legs. This is a very heavy table and turning it over will require at least two strong adults.
- 2) To protect the game surface, we suggest that you leave the game in the bottom carton during the leg assembly. Carefully cut or tear the four carton corners, so that the bottom carton becomes a flat working surface. Remove all the contents inside the carton and verify that you have all the listed parts as shown on the Parts Identifier.

#### **FIG. 1**

- 3) Place two Side Cross Panels (#1) upside down and finished side facing outward from the table cabinet. Attach four K - Style Brackets (#29) between the Side Cross Panels (#1) and the table cabinet using six Screws (#24) per Bracket. See Fig. 1. Next, attach the four Wooden Pieces (#7) to the two Sides of table cabinet using two Screws (#25) per Wooden Piece. See Fig. 1 and 1A. Pilot holes show the proper screw placement.
- 4) Place two End Cross Panels (#2) upside down and finished side facing out from the table cabinet. Attach two K-Style Brackets (#29) between the End Cross Panels (#2) and the table cabinet using six Screws (#24) per Bracket. See Fig. 1.
- 5) Attach one L-Style Bracket (#5) at each corner of table cabinet using Screws (#24) per Bracket. See Fig. 1 and 1B. **NOTE:** Two screws secure to the Side Cross Panel (#1) and two screws secure to the End Cross Panel (#2). Pilot holes show the proper screw placement.
- 6) Attach one V-Style Bracket (#4) to each corner of the table cabinet using six Screws (#24) per Bracket. See Fig. 1. Pilot holes show the proper screw placement. Make sure all connections are tighten.

24  4 X 12MM FLAT HEAD SCREW

FIG. 1B

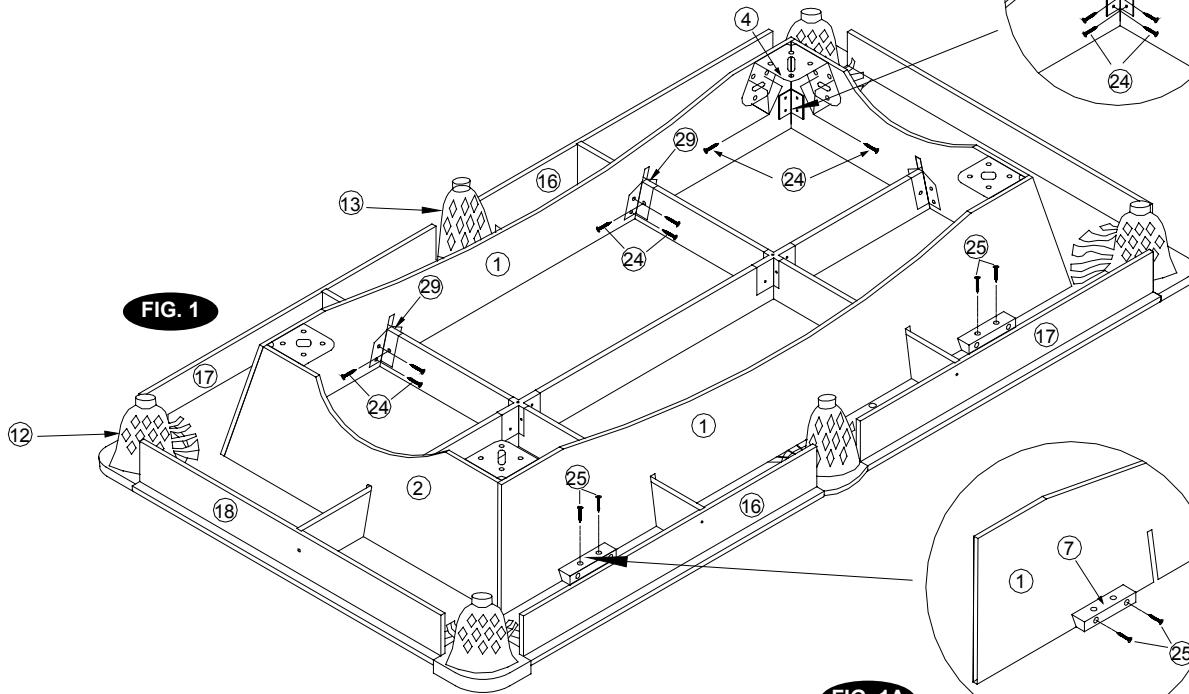
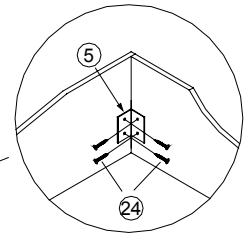

FIG. 2

7) Attach the Table Legs (#19) to each V - Style Bracket (#4) using four Allen Key Bolts (#21) and four Washers (#30) per Bracket. See Fig. 2 and 2A. Tighten all the connections.

8) Screw one Leg Leveler (#3) into each leg. See Fig. 2.

FIG. 2A

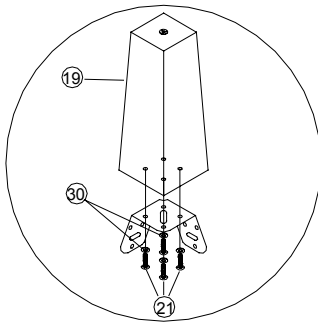
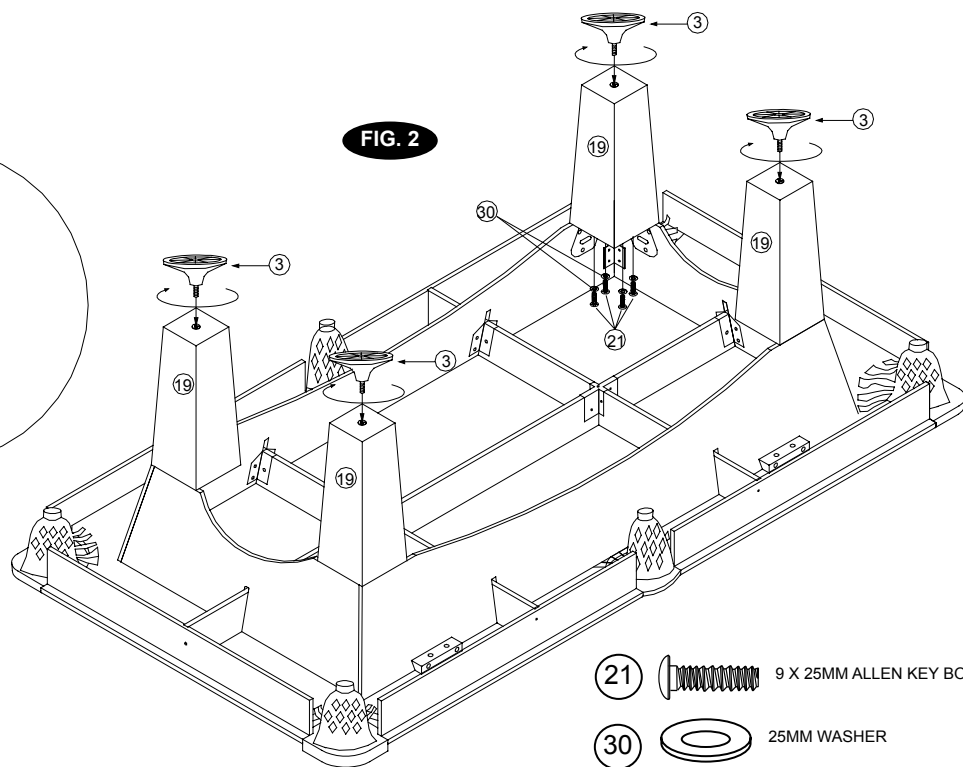



FIG. 2



21  9 X 25MM ALLEN KEY BOLT

30  25MM WASHER

**FIG.3**

- 9) Lift the table assembly from the floor with two strong adults, turn it over, and set table on its legs in the location where you will play. Go back and make sure that all connections are tight.
- 10) Starting at one end, place a level on the table and adjust the Leg Levelers (#3) up or down to ensure that the table is level. This should be done at both ends and in the middle of the table. **YOU ARE NOW READY TO PLAY.**

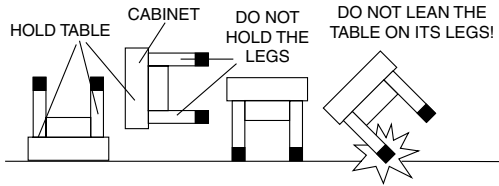

**CAUTION:** Two strong adults are recommended to turn the table as shown.  
1. Lift the table off the ground.  
2. Turn the table over.  
3. Place it on all four feet at the same time on the ground.

**FIG. 3**

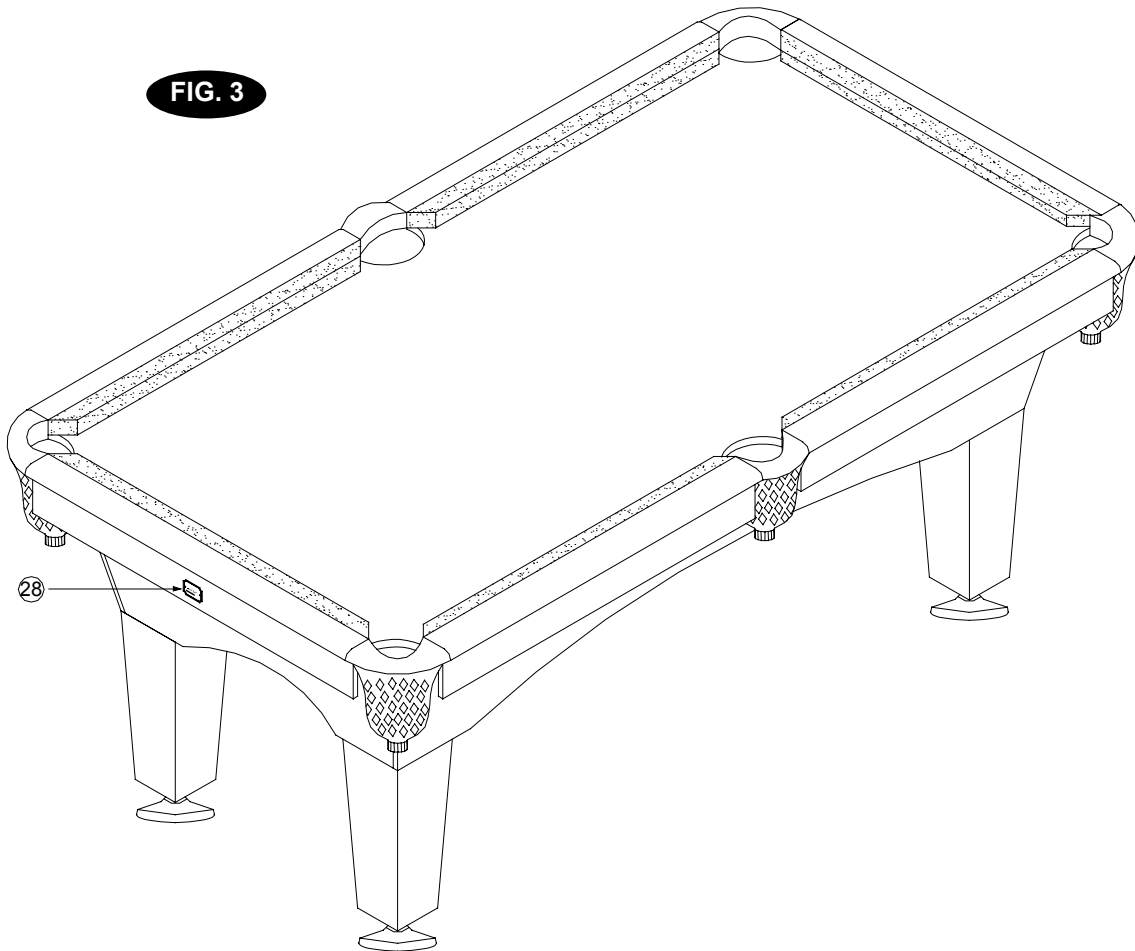

English

English

**TABLE MAINTENANCE:**

1. **TABLE:** Keep your table covered. If there is dust on the playfield or the aprons, use a vacuum or use the brush provided to remove. Do not sit on the table and do not use the table outside. For location of the black ball spot, please refer to Illustration No. 1 for positioning it correctly on the foot spot.
2. **POCKETS:** DO NOT lift the table by placing your hands under the pockets, and do not sit, lean or put pressure on the pockets.
3. **LEGS:** Check that all the edges fit properly into the grooves of the caps. When moving the table, lift the table off of its legs and place it down squarely on the legs, do not drag the table (and do not lift by the pockets).

## RULES OF PLAY - 8 BALL

### OBJECT OF THE GAME:

8 Ball is a simple game enjoyed by players of all skill levels. It is a Called Shot Game, meaning that players must announce their intended shot in advance in order for it to count. In 8 Ball, one player shoots at solid balls (numbers 1 through 7), while the opponent shoots at striped balls (numbers 9 through 15). The player who pockets his or her ball group first and then sinks the 8 ball is the winner.

### THE BREAK:

The balls are racked as shown in ILLUSTRATION 1. A flip of a coin determines which player gets to break. In subsequent games, the loser of the previous game gets to break. The cue ball must be placed behind the head string and the shooter must either : (a) pocket a ball, or (b) drive four balls to the rails. If the shooter fails to make a legal break, the opponent has the option of accepting the balls in this position or re-racking the balls and shooting the opening break again.

If any balls are pocketed on the break: the shooter stays on the table, however the table is still Open, meaning that the choice of the stripes or solids is not yet determined. The choice of stripes or solids is determined by the first called shot made after the break.

If the 8 ball is pocketed on the break: the shooter stays on the table with the option of spotting the 8 ball and continuing play, or re-racking the balls and breaking again.

If the shooter scratches on the break: if the cue ball is pocketed on the break : (a) all balls pocketed remain pocketed, except the 8 ball which is spotted, (b) the table is open, (c) the opposing player has the cue ball in hand and may place it anywhere behind the head string and shoot at any ball that is not behind the head string.

### PLAYING THE GAME:

After the break, regardless of whether any balls were pocketed on the break, the table is Open, with the choice of stripes or solids determined by the next legally pocketed ball.

In the course of play, a shooter must call each shot in advance, by indicating the ball to be made and the pocket into which it will be made. It is not necessary to indicate details such as cushions, banks, caroms, etc. Failure to make the shot as called results in a loss of turn. If the shot is made as called, then any other balls pocketed remain pocketed. However, if the called shot is not made and any other balls are pocketed, then the shooter's ball(s) that were pocketed would be spotted and any of the opponent's balls would remain pocketed.

In order to execute a Legal Shot, the first ball hit must be one of the balls in the shooter's group (stripes or solids) and the object ball must be pocketed or the cue ball or any object ball must come into contact with a rail. (Note: It is legal for the shooter to bank the cue ball off a rail before hitting the object ball.)

A player who legally pockets a ball continues play until missing or committing a Foul. Once a player's ball group (stripes or solids) is pocketed, the player may play the 8 ball. Again, the player must clearly indicate the intended pocket, even if it appears obvious. A player who legally pockets all of his ball group and the 8 ball is the winner.

### FOULS:

1. Failure to execute a legal shot as defined above.
2. A scratch shot (shooting the cue ball into a pocket or off the table)
3. Moving or touching any ball by means other than legal play.
4. Shooting an intentional jump shot over another ball by scooping the cue stick under the cue ball. A jump shot executed by striking the cue ball above center is legal.
5. Using the 8 ball first in a combination shot when the table is not open.

### FOUL PENALTY:

Opposing player gets "cue ball in hand". This means that the player can place the cue ball anywhere on the table (does not have to be behind the head string except on the opening break).

### SPOTTING BALLS:

Whenever an object is to be spotted, the object ball is spotted on the long string as close to the foot spot as possible.

ILLUSTRATION #1

HEAD OF TABLE

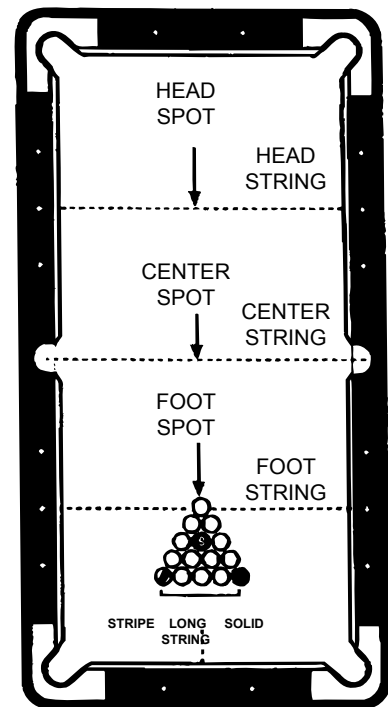

FOOT OF TABLE

**LOSS OF GAME:**

A player committing any of the following infractions loses the game :

1. Fouls when pocketing the 8 ball.
2. Pockets the 8 ball on the same stroke as the last of his group of balls.
3. Scratches when the 8 ball is his legal object ball.
4. Jumps the 8 ball off the table at any time.
5. Pockets the 8 ball in a pocket other than the one designated.
6. Pockets the 8 ball when it is not the legal object ball (except on the break).

**RULES OF PLAY - 9 BALL**

**OBJECT OF THE GAME:**

Nine-Ball is a popular game enjoyed by players of all skill levels. In 9 Ball, the shooter must make contact with the lowest numbered ball first. The player who sinks the 9 ball is the winner.

**THE BREAK:**

**Balls numbered 1 through 9 are racked in a “diamond” shape with the 1 Ball at the top of the diamond and on the foot spot and the 9 Ball in the center.** See ILLUSTRATION #2. The cue ball must be placed behind the head string and the shooter must make contact with the 1 Ball first and either : (a) pockets a ball, or (b) drives four balls to the rails. If the shooter fails to make a legal break, the opponent has the option of accepting the balls in this position or re-racking the balls and shooting the opening break again. If the cue ball is scratched on the break, the incoming player may not play a “Push Out” (see PUSH OUT), but places the “cue ball in hand” anywhere on the table.

**PLAYING THE GAME:**

After the break, the next shot may be played as a “Push Out”, or, if the breaker pockets one or more balls, he continues to shoot until he misses, fouls, or wins the game. Once a player misses or fouls, the opponent begins to shoot until missing, committing a foul, or winning. The game ends when the 9 Ball is pocketed on a legal shot.

**PUSH OUT:**

The player shooting immediately following a legal break may play a Push Out in an attempt to move the cue ball into a better position. In a Push Out, a ball does not have to make contact with any ball or rail and is not considered a foul unless other foul rules apply. The player must announce the intention of playing a Push Out before the shot, or it is considered normal play. Any ball pocketed on a Push Out does not count and remains pocketed (except the 9 Ball). Following a Push Out, the incoming player: a) must shoot from that position or b) may pass the shot back to the other player.

**FOULS:**

1. Failure to execute a legal shot as defined above.
2. Failure to make first contact with the lowest numbered ball on the table.
3. A scratch shot (shooting the cue ball into a pocket or off the table)
4. Moving or touching any ball by means other than legal play.
5. When the object ball is not pocketed, failure to drive the any ball to a rail after the cue ball has made contact with the object ball.
6. Shooting an intentional jump shot over another ball by scooping the cue stick under the cue ball. A jump shot executed by striking the cue ball above center is legal.
7. Driving any ball off of the table. The object balls are not re-spotted (except the 9 Ball).

**FOUL PENALTY:**

Opposing player gets “cue ball in hand”. This means that the player can place the cue ball anywhere on the table. Balls pocketed on the foul are NOT re-spotted (except the 9 Ball). Any player that commits a foul three consecutive times on three successive shots without making a legal shot in between loses the game.

Come Explore our Website! ([www.sportcraft.com](http://www.sportcraft.com)) Join our mailing list to receive more information on product updates and event announcements. Or, complete your warranty registration on-line. You can even order replacement parts, and learn more about our company.

**ILLUSTRATION #2**

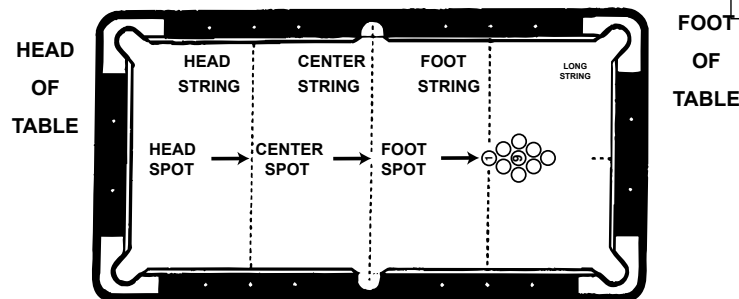

**SPORTCRAFT**   
 Mt. Olive, NJ 07828  
[www.sportcraft.com](http://www.sportcraft.com)  
 Printed in China

# SPORTCRAFT

## LIMITED WARRANTY

### Limited Warranty

Sportcraft, Ltd. (the "Company") warrants the Product to be free from defects in workmanship and materials under normal use and conditions FOR A PERIOD OF ONE YEAR FROM THE DATE OF ORIGINAL PURCHASE in the United States and Canada.

### Product Registration Card

The Product Registration Card must be filled out completely and mailed to the Company at the address printed on the card within 10 days from the date of your purchase of the Product.

### What Is Covered

Except as provided below, this Limited Warranty covers all defects in materials and workmanship. This Limited Warranty is void if the Product is:

- Damaged through improper usage, negligence, misuse, abuse, transportation damage, acts of nature, or accident (including failure to follow the instructions supplied with the Product)
- Used in commercial applications or rentals
- Modified or repaired by anyone not authorized by the Company.

### What Is Not Covered

This Limited Warranty does not cover expendable items such as batteries, light bulbs, fuses, accessories, cosmetic parts and other items that wear out due to normal usage.

### What The Company Will Pay For

If during the one year Limited Warranty period, any part or component of the Product is found by the Company to be defective, the Company will, at its option, reapeire the Product, replace the Product with a new Product (either the same or an equivalent model) or cause the original retailer of the Product to exchange the Product with a new Product (either the same or an equivalent model) or refund the original purchase price of the Product, without charge for labor or parts. The Company's obligation to repair, replace or exchange the Product, however, shall be limited to the amount of the original purchase price of the Product.

### How To Obtain Warranty Service

In order to enforce your rights under this Limited Warranty, you must follow these procedures:

- You must have completed and mailed the Product Registration Card to the Company within 10 days of purchase of the Product.
- You must include THE ORIGINAL COPY OF YOUR SALES RECEIPT.
- You must call the Company's Consumer Service Department at 1-800-526-0244 from 9:00 A.M. to 5:00 P.M. (EST) to notify the Company of the nature of the problem and to obtain instructions for how to obtain servicing. At the Company's option, the Product may be serviced at your location or at a location designated by the Company.
- If you are instructed to return the Product to the Company for servicing, you are responsible for shipping the Product, at your expense, to the address designated by the Company in packaging that will protect against further damage.
- You must also include your name, address, daytime telephone number, model number of the Product and a description of the problem.
- The Company will pay for any shipping charges to return the repaired or replaced Product to you.

**THIS LIMITED WARRANTY IS AVAILABLE ONLY TO THE ORIGINAL PURCHASER OF THE PRODUCT AND IS VALID IN THE UNITED STATES AND CANADA ONLY.**

**THE COMPANY'S LIABILITY IS LIMITED TO THE REPAIR OR REPLACEMENT, AT ITS OPTION, OF ANY DEFECTIVE PRODUCT AND SHALL NOT INCLUDE ANY LIABILITY FOR INDIRECT, INCIDENTAL OR CONSEQUENTIAL DAMAGES OF ANY KIND.**

**THIS WARRANTY IS EXPRESSLY MADE IN LIEU OF ALL OTHER WARRANTIES, EXPRESSED OR IMPLIED.**

**SOME STATES DO NOT ALLOW LIMITATIONS ON HOW LONG AN IMPLIED WARRANTY LASTS OR DO NOT ALLOW FOR EXCLUSION OF INCIDENTAL OR CONSEQUENTIAL DAMAGES. TO THAT EXTENT, THE ABOVE LIMITATIONS MAY NOT APPLY TO YOU.**

This Limited Warranty gives you specific legal rights, but you may also have other rights that vary from state to state.

If you have questions regarding this Limited Warranty or the operation of the Product, you may call or write us:



Sportcraft, Ltd.®  
Consumer Service Department  
313 Waterloo Valley Rd.  
Mt. Olive, NJ 07828  
1-800-526-0244  
www.sportcraft.com

0504 TG

**\*\*NOTE: Please save your original proof of purchase as it is needed should you require warranty service.**

