

# HIDEAWAY

assembly manual

**CLASSIC**  
**SPORT®**



# 9-in-1

## COMBO TABLE

Model: X7535 / 4-1-25-279



# INTRODUCTION

**CONGRATULATIONS!!** You have chosen a game with unsurpassed value that will provide years of entertainment. Thank you for your support!



**COMPLETELY UNPACK ALL COMPONENTS AND VERIFY YOU HAVE ALL THE CORRECT PIECES. IF YOU NOTICE DEFECTIVE OR MISSING PARTS, DO NOT RETURN THE TABLE TO THE STORE. INSTEAD, PLEASE CALL US TOLL FREE AT:**



**1-800-526-0244 (M-F 9:00AM-5:00PM EST)**

Please read the instructions carefully after you have unpacked the carton, and familiarize yourself with the assembly order & names of parts.



**THIS ITEM HAS MANY PARTS AND STEPS OF ASSEMBLY, AND IT IS VERY IMPORTANT THAT THESE STEPS ARE FOLLOWED CLOSELY. FOR THIS REASON, IT IS IMPORTANT TO HAVE TWO ADULTS AND A FEW HOURS SET ASIDE FOR ASSEMBLY.**



If at any time you have questions regarding your table, please do not hesitate to contact us via:

**PHONE:** 1-800-526-0244 (M-F 9:00am-5:00pm EST)  
**WEB:** [www.sportcraft.com](http://www.sportcraft.com)  
**MAIL:** **Sportcraft, Ltd.**  
Attn: Customer Service  
313 Waterloo Valley Road  
Budd Lake, NJ 07828 USA

---

## BEFORE YOU BEGIN

### IMPORTANT NOTES:

- Your table will be assembled upside down at first. **FOR YOUR SAFETY** and to avoid damaging the table, please do **NOT** flip the table over onto its legs unless **YOU HAVE HELP FROM OTHERS**.
- To protect the surfaces of the table during assembly, find a clean, level place to work on. Using the box for this works well.

### ASSEMBLY TIPS:











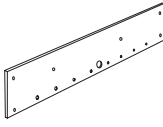

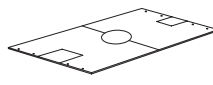
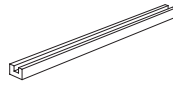



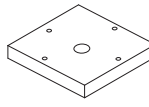
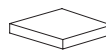
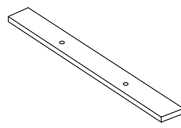
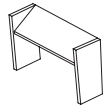
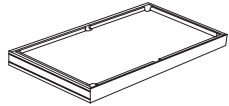

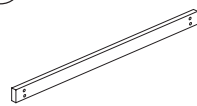
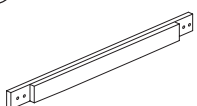

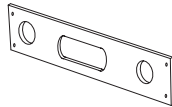

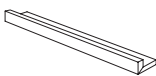

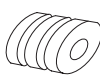
- When assembling parts that have more than one bolt, start all the bolts by hand for that particular step **BEFORE** you tighten them down.
- Two adults must assemble this game table.





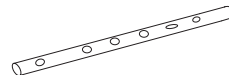
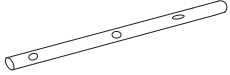
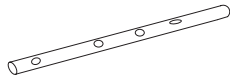
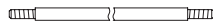







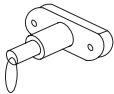
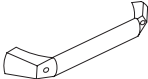





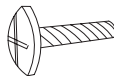
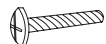
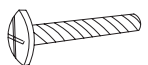





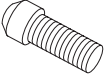
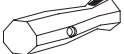

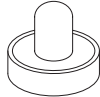

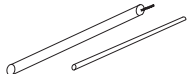

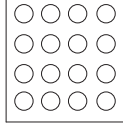
### TOOLS NEEDED:

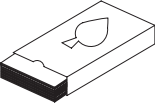
- Phillips head screwdriver
- Wrench and Allen Key (included)
- An electric screwdriver is helpful in assembly, however, be sure to **SET AT LOW TORQUE** and **USE EXTREME CAUTION**; you can overtighten the hardware and strip the screws, or make them poke through the table's parts!

# ASSEMBLY PARTS LIST

 <p>Soccer side panel 2 Pieces</p>	 <p>Soccer end panel 2 Pieces</p>	 <p>Soccer playing field 1 Piece</p>	 <p>Field support brace 3 Pieces</p>	 <p>Leg panel A 4 Pieces</p>
 <p>Leg panel B 4 Pieces</p>	 <p>Leg panel C 4 Pieces</p>	 <p>Leg Base 4pcs</p>	 <p>Leg Cap 4pcs</p>	 <p>Base end rail 2 Pieces</p>
 <p>Ball catcher 2 Pieces</p>	 <p>Billiard &amp; Hockey cabinet 1 Piece</p>	 <p>Drawer door 1 Piece</p>	 <p>Lower Side Support 2pcs</p>	 <p>Upper Side Support 2pcs</p>
 <p>Inside End Panel-R 1pc</p>	 <p>Inside End Panel-L 1pc</p>	 <p>Outside End Panel 2pcs</p>	 <p>Top end rail 2 Pieces</p>	 <p>Shelf 2 Pieces</p>
 <p>Bowling/Shuffle Board/Backgammon/Playing Surface 1 Piece</p>	 <p>Bumper 16 Pieces</p>	 <p>5/8\"X1-1/2\" Steel washer 16 Pieces</p>	 <p>5/8\"X1-1/2\" Plastic washer 16 Pieces</p>	 <p>Rod end cap 8 Pieces</p>
 <p>Ball Entry Cup 2 Pieces</p>	 <p>Home player 13 Pieces</p>	 <p>Visitor player 13 Pieces</p>	 <p>Five Player Rod 2 Pieces</p>	 <p>Two Player Rod 2 Pieces</p>
 <p>Three Player Rod 4 Pieces</p>	 <p>1/4\" Cabinet rod 3 Pieces</p>	 <p>Side Ramp 2 Pieces</p>	 <p>Left end ramp 2 Pieces</p>	 <p>Right end ramp 2 Pieces</p>

# ASSEMBLY PARTS LIST

<p>36</p>  <p>Lock bolt 4 Pieces</p>	<p>37</p>  <p>Drawer handle 4 Pieces</p>	<p>38</p>  <p>1/4"X2-1/2" Leg bolt 16 Pieces</p>	<p>39</p>  <p>1-1/4" Flat screw 16 Pieces</p>	<p>40</p>  <p>1-3/4" Flat screw 118 Pieces</p>
<p>41</p>  <p>1/2" Phillips Head Screw 6 Pieces</p>	<p>42</p>  <p>1/2" Screw 8 Pieces</p>	<p>43</p>  <p>5/8" Bolt 8 Pieces</p>	<p>44</p>  <p>1/8" Bolt 8 Pieces</p>	<p>45</p>  <p>8#X1-1/8" Screw 26 Pieces</p>
<p>46</p>  <p>8# Lock Nut 26 Pieces</p>	<p>47</p>  <p>1/4" Lock nut 6 Pieces</p>	<p>48</p>  <p>5/16" Lock nut 4 Pieces</p>	<p>49</p>  <p>1/4" Washer 22 Pieces</p>	<p>50</p>  <p>5/16" Washer 4 Pieces</p>
<p>51</p>  <p>Stopper bolt 4 Pieces</p>	<p>52</p>  <p>Wooden handle 8 Pieces</p>	<p>53</p>  <p>Hockey puck 2 Pieces</p>	<p>54</p>  <p>Striker Felt 2 Pieces</p>	<p>55</p>  <p>Hockey striker 2 Pieces</p>
<p>56</p>  <p>Soccer ball 2 Pieces</p>	<p>57</p>  <p>36" Cue 2 Pieces</p>	<p>58</p>  <p>Chalk 2 Pieces</p>	<p>59</p>  <p>Billard balls 1 set</p>	<p>60</p>  <p>Triangle 1 Piece</p>
<p>61</p>  <p>Card deck 1 Set</p>	<p>62</p>  <p>Bowling ball 1 Piece</p>	<p>63</p>  <p>Bowling pin 1 Set</p>	<p>64</p>  <p>Checker 1 Set</p>	<p>65</p>  <p>Chess 1 Set</p>
<p>66</p>  <p>Shuffle puck 1 Set</p>	<p>67</p>  <p>Hardware cap 8 Pieces</p>	<p>68</p>  <p>Wrench 1 Piece</p>	<p>69</p>  <p>Allen key 1 Piece</p>	

## STEP 1

With the two (#1) SIDE APRONS upside down, slide the (#3) PLAYING FIELD with the graphics facing down into the slots on the inside of the two panels as shown in Fig.1.

*One person should hold the side aprons upright while the second person slides the playing surface into the grooves on the inside of the aprons.*

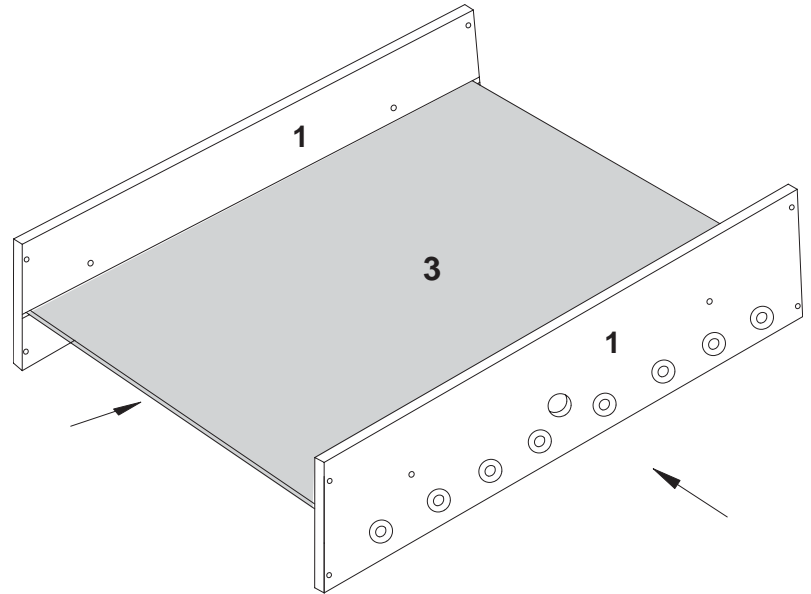

## STEP 2

Place the (#4) PLAYING FIELD SUPPORT BRACES onto the playing surface, aligned with the holes in the side panels.

Insert the (#32) CABINET RODS through one side panel, along the groove in the support braces, and through the other side panel. Secure with the (#47) LOCK NUTS and (#49) WASHERS.

*Do not tighten completely, until the end panels are attached.*

Attach each (#2) SOCCER END PANEL to the cabinet using six (#40) SCREWS.

Now, completely tighten the (#32) CABINET RODS.

*With assistance from at least one other person, flip the cabinet over for the next steps.*

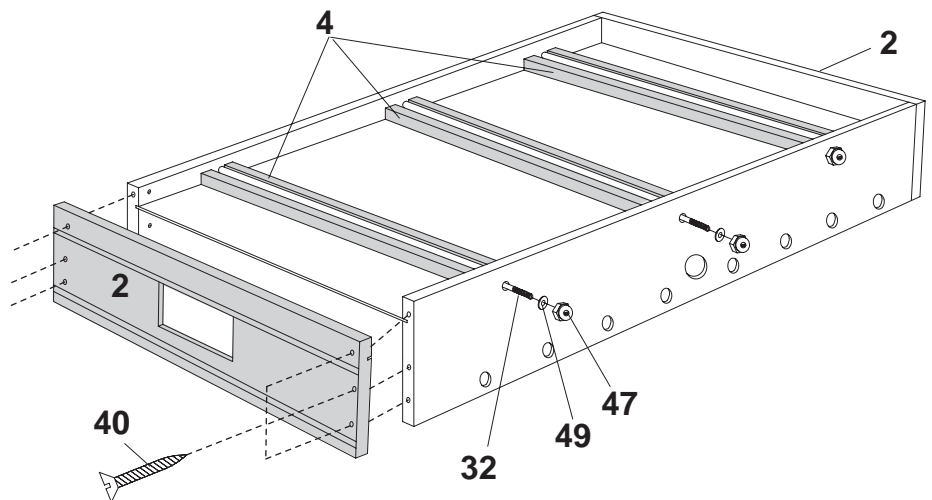

## STEP 3

To ensure correct placement, place all of the ramps (parts 33, 34, 35) on the surface before you affix them to the surface.

Remove the protective cover on the tops of the ramps. Peel off adhesive strip under one (#33) SIDE RAMP and stick onto the wood; apply pressure to secure.

Repeat this process for the rest of the ramps.

Attach the (#26) BALL ENTRY CUPS to the outsides of the side aprons as shown, using three (#41) SCREWS for each cup.

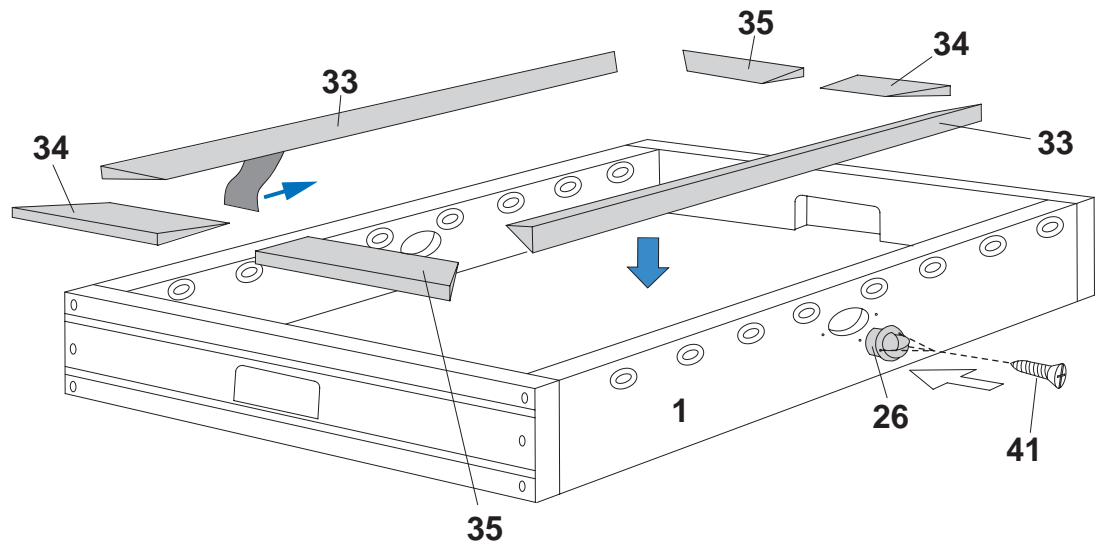

## STEP 4

A) Note where the handle holes are on each of the rods. Each team will have a 3-man 'goalie' rod, 2-man 'defense' rod, a 5-man 'midfield' rod, and a 3-man 'forward' rod. Please arrange all eight rods in your table according to the diagram, which shows the Away Team being assembled first.

### Rod Assembly Tips:

1. The players should have their backs to their respective goals. The (#46) LOCK NUT goes on the back of the player, while the (#45) BOLT is on the front.

2. The (#24) PLASTIC WASHER goes on the cabinet side of the (#22) rubber bumpers while the (#23) STEEL WASHER goes on the player side of the bumpers.

3. Attach the (#52) HANDLES using (#43) SCREWS. The notch on the HANDLE should be on top when the PLAYERS' feet are down.

B) After washers, bumpers, and players are attached to the rods, push the (#25) ROD END CAPS onto the ends of the rods, opposite the handle.

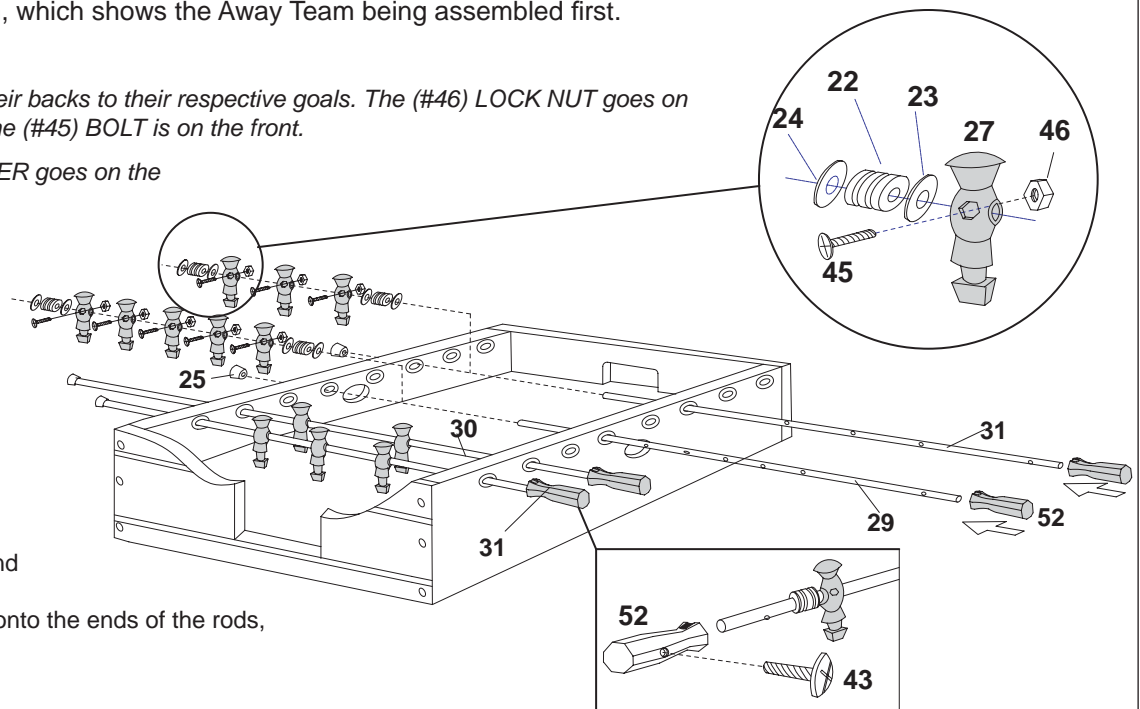

## STEP 5

Assemble each leg as shown below.  
Repeat this step for each leg.

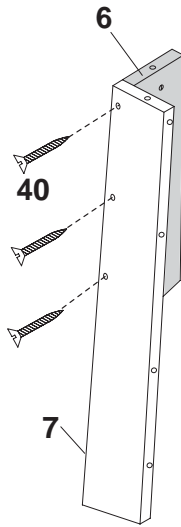

First attach the (#6) LEG PANEL D to the (#7) LEG PANEL C using (#40) SCREWS.

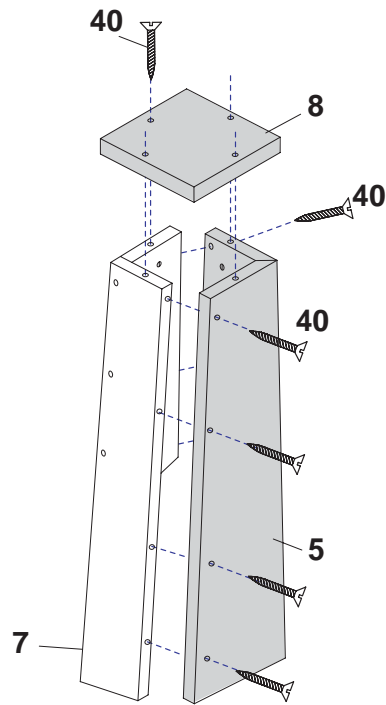

Next, attach (#5) LEG PANEL B to the assembly using (#40) SCREWS as shown, following with (#8) LEG BASES also using (#40) SCREWS.

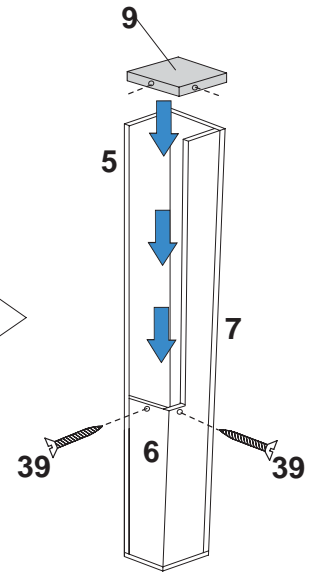

Finally, slide the (#9) LEG CAPS into the leg as shown, and secure using (#39) SCREWS.

## STEP 6

Attach an (#15) UPPER SIDE SUPPORT to one right leg and one left leg using four (#38) BOLTS and (#49) WASHERS as shown.

Now attach a (#14) LOWER SIDE SUPPORT to the assembly using four (#38) BOLTS and (#49) WASHERS.

Repeat this step for the other side supports and legs, and place the leg assemblies off to the side. Now you will build the end panel assemblies.

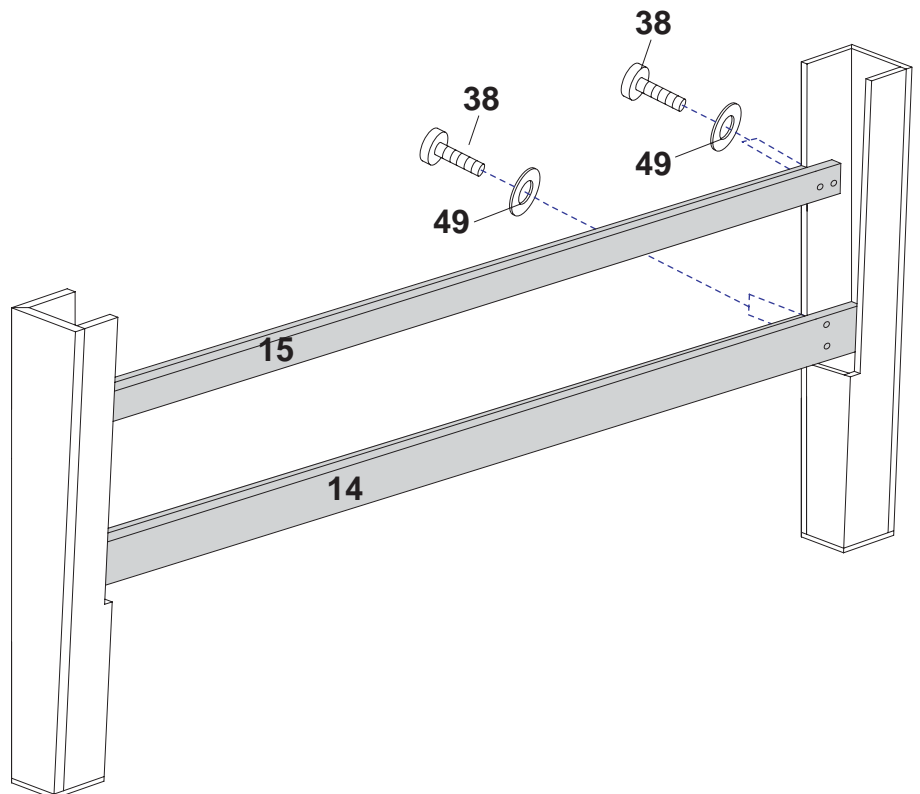

## STEP 7

Attach the (#36) LOCK PINS to the (#16) INSIDE END PANEL as shown using (#42) SCREWS.

Now attach the (#51) STOPPER BOLTS using (#48) BOLTS and (#50) WASHERS.

Please note the position of the STOPPER BOLTS on the end panels. These will have to mirror each other when attached to the leg frames.

Repeat this step for the other INSIDE END PANEL.

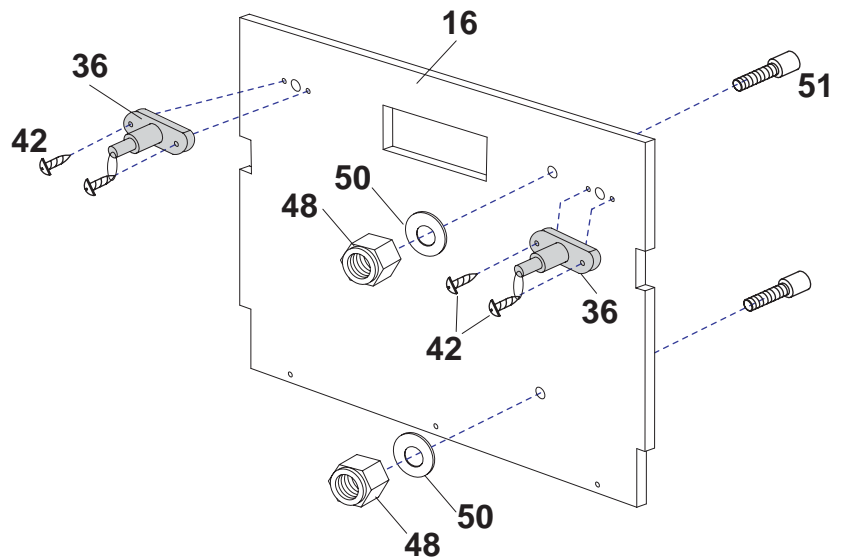

## STEP 8

First assemble the goal shelves by attaching the (#11) BALL CATCHERS to the (#10) BASE END RAIL.

Then attach one goal shelf to each of the INSIDE END PANELS (#16 & #17) as shown, using (#40) SCREWS.

Finally secure one (#20) ACCESSORY SHELF to each INSIDE END PANEL, also using (#40) SCREWS.

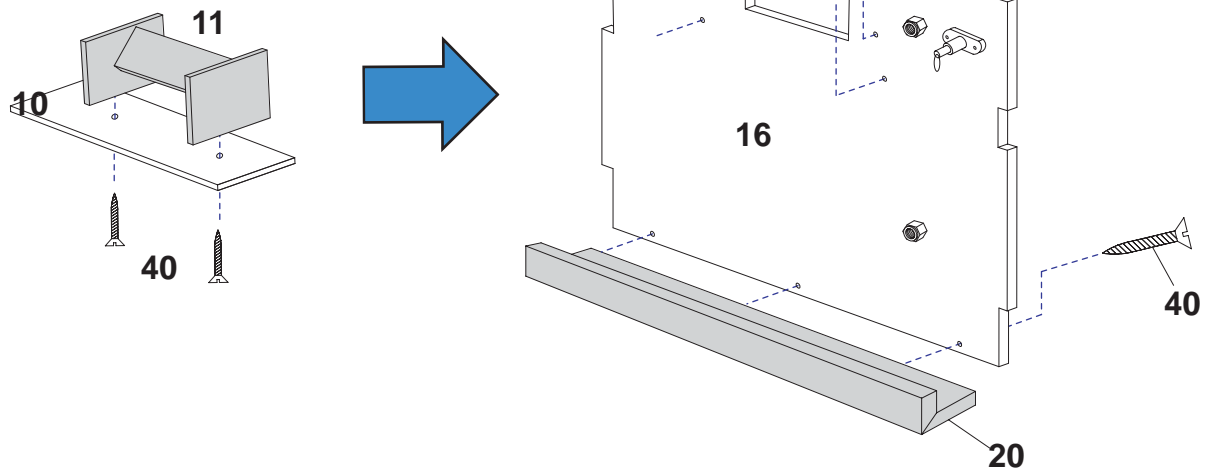

## STEP 9

Once again, note which side of the end panels the **STOPPER BOLTS** are located. When you place the end panel assemblies into the frame, the stopper bolts for each panel must be on the same side of the table.

Fit the end panel assemblies into the leg frames as shown, and secure them to the legs using (#40) SCREWS.

You will use 12 screws for each end panel assembly.

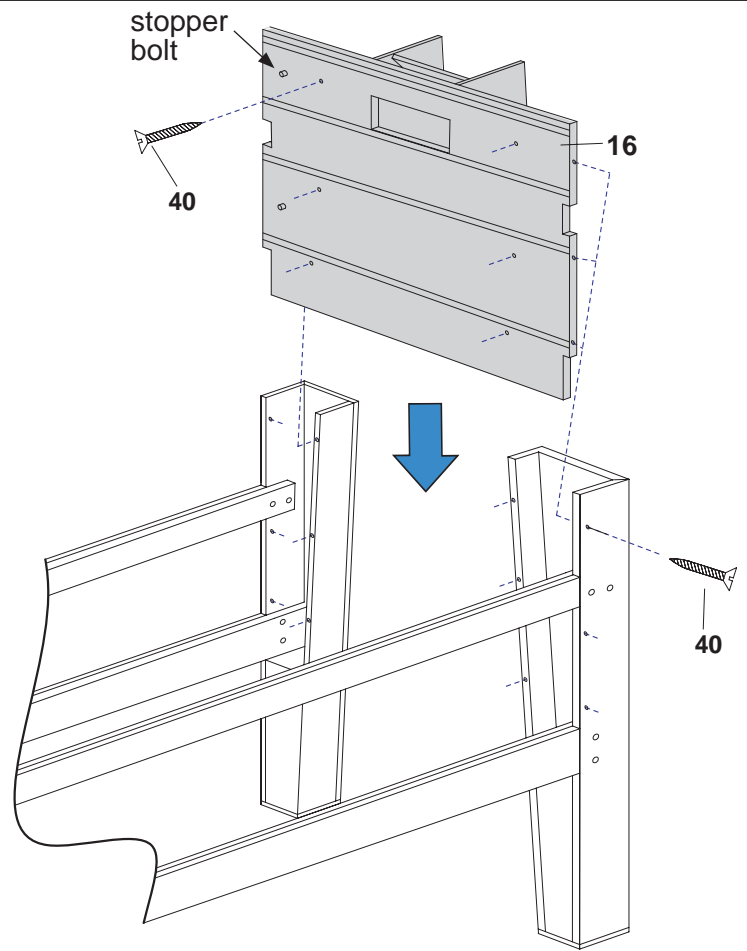

## STEP 10

Once the end panel assemblies are in place and secure, attach the (#19) TOP END RAILS using (#40) SCREWS.

Once the screws are in place, push one (#67) SCREW CAP down onto each screw head.

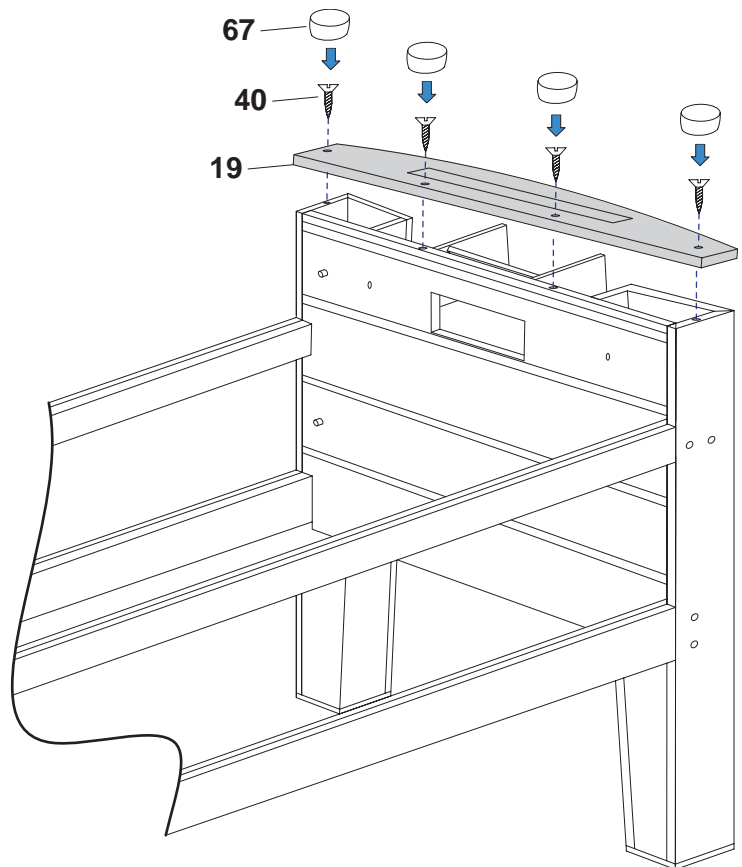

# STEP 11

Now attach the (#18) OUTSIDE END PANELS as shown, using (#39) SCREWS.

Slide the game "drawers" into the cabinet frame. Because of the stopper bolts, the drawers can only enter and exit the frame from one side.

*Before sliding the billiards cabinet in place, make sure the fan motor cord is bunched and secured inside the (#13) Drawer Door.*

The (#21) Multi-Gameboard surface fits onto the hockey or billiard surface for storage, and most of the accessories will fit onto the accessory shelves on the end panel.

*To easily slide the soccer table into the cabinet when it is in a non-playing position, turn each rod so the players are horizontal, then slide into place.*

Attach the (#37) DRAWER HANDLES to each of the cabinets as shown, using two (#44) SCREWS for each handle.

*Remember, to prevent injury, at least two adults are needed to interchange the game cabinets.*

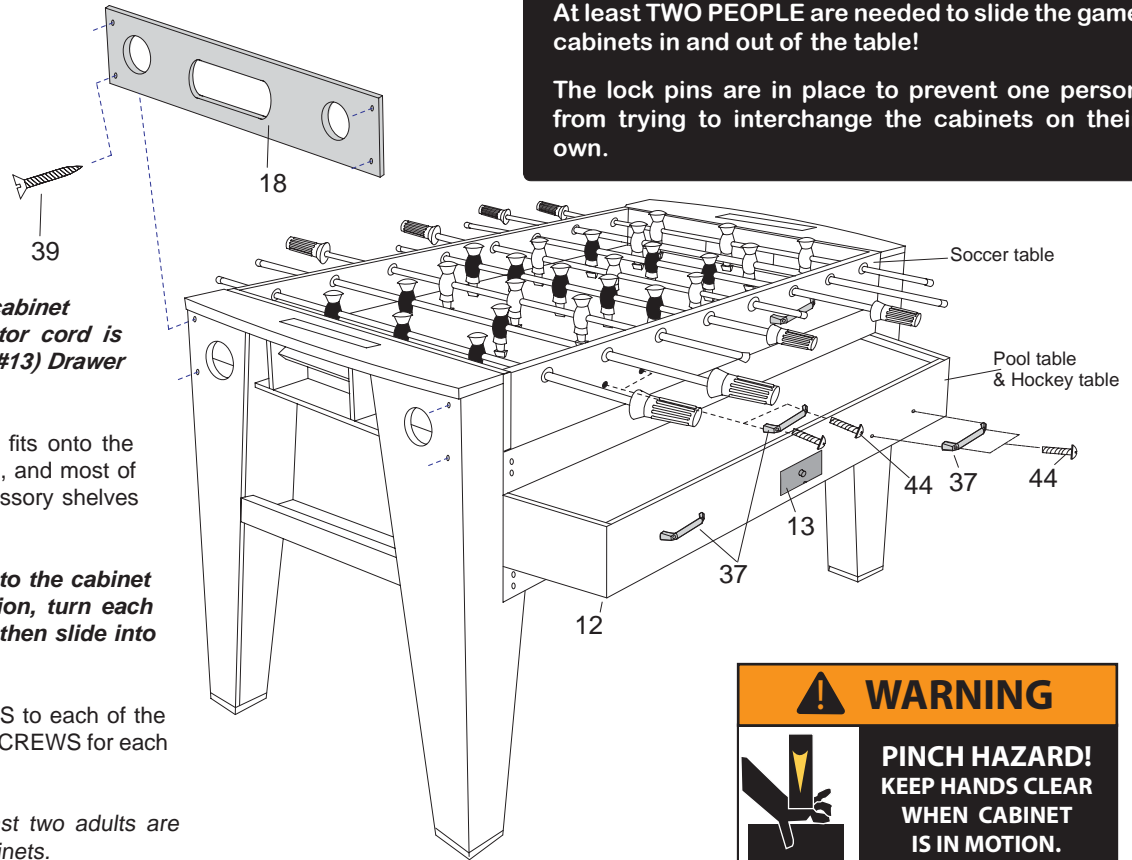

## CAUTION: HEAVY!

At least TWO PEOPLE are needed to slide the game cabinets in and out of the table!

The lock pins are in place to prevent one person from trying to interchange the cabinets on their own.

### 9-in-1 GAME TABLE CONFIGURATIONS

Each game must be played in the top drawer position. There are safety pins that lock each game into place in the top position. With the stopper bolts in place, the cabinets can only be slid into and out of the frame in one direction.

Table Soccer	Place the assembled soccer cabinet into the top drawer position. Push safety pins to lock in place.
Air-Powered Hockey	The air-powered hockey and the billiards games share the same cabinet. For best results, remove the billiard surface to allow the hockey fan to "breathe". Flip the cabinet so the air-powered hockey is upright, and slide it into the top position. Pull the fan motor cord out from the trap door in the side of the cabinet, and plug it into a wall outlet. Click the cord control to turn the air fan on.
Billiards	Slide the hockey cabinet out, flip it over so the billiards surface is on top, and slide back into the cabinet. Unplug the air-powered hockey cord from the wall and tuck it into the trap door in the side of the cabinet. Turn the knob to lock the door shut.
Shuffleboard / Bowling	Turn hockey fan off, and place gameboard onto the hockey board. Place game pieces onto board.
Chess / Checkers / Backgammon	Same as shuffleboard/bowling.

 **IMPORTANT NOTE:** If the game cabinets do not appear to fully slide into position, check that the cabinet was slid into the frame correctly; the stopper bolts on the inside end panels fit to the routed grooves on the ends of the game cabinets.

# GAME RULES

## TABLE SOCCER:

---

- To start play, flip a coin to see which team or player will serve first. To begin, serve the ball through the side entry cup or with the Ball Server.
- Pass and score by pushing and pulling rods and twisting grips. Spinning the rods is considered illegal in tournament play. If playing as teams (more than two players total), once the ball is served, players may not change position on the rods until: one team scores; a team requests a timeout (maximum 2 per round); the ball must be served again; or between rounds.
- A point is scored when the ball enters the goal. A serve, by the team last scored upon, follows each goal. Teams change table sides after each round.
- Intentional jarring or tapping of table during play is illegal, and reaching into the playing area during play is illegal (except for a dead ball). A ball is considered a DEAD BALL when it has completely stopped its motion or is unreachable by any player.
- If a ball stops between the goal and the two-man rod, then it is put back into play by placing it in the corner that is nearest the dead ball spot. If the ball completely stops anywhere else on the playfield between both two-man rods, it is put back into play with a serve by the team that originally served the ball.
- If a ball leaves the playing area during play (other than through the goals), the ball is considered OUT OF PLAY. The ball is returned to play with a serve by the team which originally served the ball.
- This table is designed to be played with either two or four players. We recommend that all others should stand clear of the playing area if they are not playing.

## HOCKEY:

---

- This game is designed to be played with two (2) players, one at each end, or with four (4) players, two at each end of the game table.
- Flip a coin to determine who will begin play, or a face-off can be held at the center of the table.
- Play begins when the puck is placed on the playing surface. Players must hit the puck with the hand-held pushers and attempt to shoot into the opponent's goal. The pusher must not come to rest in front of the goal during play, making it difficult to score a point.
- One point is awarded when a puck is shot into the opponent's goal.
- Winning the game: the winning score is accomplished by being the first player to reach a predetermined score or by being the player to score the most points within a given period.

## CHESS:

---

### ELEMENTS:

- In a game of chess there are two opponents taking turns making moves; one using white pieces, one using black pieces. White always moves first to begin the game. Each player has six different kinds of chessman: one queen, one king, two rooks, two bishops, two knights and eight pawns. The chessboard consists of sixty-four squares – eight horizontal rows (ranks) and eight vertical rows (files).
- Facing the board a white square is always at the lower, right corner. Set the white pieces on the board, from left to right on the first row as follows: rook, knight, bishop, queen, king, bishop, knight and rook. Set the eight pawns across the second row. Set the black pieces, from left to right, facing the player, on the first row as follows: rook, knight, bishop, king, queen, bishop, knight and rook. The two kings and two queens should be facing each other on the vertical rows. Set the eight pawns across the second row.

### MOVE:

- Each of the chessmen has a different way of moving.
  - KING:** can move one square in a direction-vertically, horizontally and diagonally. The king can capture and opposing chessman on an adjacent square and remove it.
  - QUEEN:** can move like the king, in any direction but with an important difference. The queen can keep on moving until she is blocked by some obstacle to her progress, such as a friendly or an opposing chessman. The queen captures by landing on the opponent's square and removing the captured piece.
  - ROOK:** can move vertically or horizontally, one direction at a time until blocked by the presence of a friendly or an opposing chessman. The rook captures by landing on the opponent's square and removing the opposing chessman from the board.
  - BISHOP:** can move only diagonally, one direction at a time until blocked by the presence of a friendly or an opposing chessman. The bishop captures by removing the opposing piece from the board.

# GAME RULES (cont.)

**KNIGHT:** can move – 1) one square forward or backward; then two squares to the right or left; or 2) one square to the right or left; then two squares forward or backward. The knight can leap over the chessman on its way to its third square and captures and removes only on the end-square of its move. The knight cannot capture any chessman that it leaps over.

**PAWN:** can move only in one direction to the square straight ahead unless the square is occupied by a friendly or hostile man. Each pawn only on its first move, has the choice of advancing one square or two squares. A pawn may capture a hostile piece only if it is in front of it to the left or right diagonally.

## CHECK

- When the king of a player can be taken by a piece of the opponent, one says that the king is in check. For instance, the white player moves his rook to a position such that it attacks the black king, i.e., if black doesn't do anything about it, the rook could take the black king in the next move: we say that the white rook gives check. It is considered good manners to say check when one checks ones opponent. It is not allowed to make a move, such that ones king is in check after the move. If a player accidentally tries to make such a move, he must take the move back and make another move (following the rules that one must move with the piece one has touched).

## MATE

- When a player is in check, and he cannot make a move such that after the move, the king is not in check, then he is mated. The player that is mated lost the game, and the player that mated him won the game.

## CHECKERS:

### OBJECTIVE:

- Each player tries to either move the pieces so that the opponent is unable to make a move, or capture all of the opponent's pieces and remove them from the playing board.

### BEFORE YOU BEGIN:

- Each player arranges the twelve pieces on the twelve dark squares in the first three rows on their side of the board. The game is played only on the dark squares. The player with the dark, or black pieces, always takes the first turn. Each player may move only one piece per turn. The pieces are moved one square at a time diagonally only. Once a player has touched a piece, it must be moved in that turn. Pieces may not be moved backward.

### THE GAME:

- An opponent's pieces are captured when a piece jumps over it to the next square, which must be vacant/ More than one piece may be captured each turn, as long as there is a vacant square to land on after each successive jump, but a piece may not be jumped more than once. A player has the choice whether to capture a small or large number of pieces. If the player decides to capture a large number of pieces, all the possible jumps and captures must be completed. Once a piece reaches the last row on the opponent's side of the board, it becomes a 'king'. The player's turn ends when the piece becomes a king. A king is 'crowned' by placing another piece of the same color on top of it. Once a piece becomes a king, it may be moved either forward or backward along the diagonal squares to a vacant square. A king may be captured by either a regular piece or by another king piece. If neither player can remove all the opponent's pieces or prevent the opponent from moving, then the game ends in a draw.

## BACKGAMMON: *Copied, with permission, from Backgammon Galore, <http://www.bkgm.com>.*

### OBJECTIVE:

- To be the first player to move all of your pieces to your inner table where they can be removed (borne off) from the board. The first player to remove or "bear off" all his or her pieces from the board wins.

### THE BOARD:

- The board consists of 24 points, or triangles, of alternating colors. A 'bar' divides the board down the middle. Players sit on opposite sides of the board. The first six points are called their 'inner table'. Points seven through twelve are the player's 'outer table'. Each player has 15 pieces of a different color from their opponent's pieces.

### BEFORE YOU BEGIN

- Pieces are placed on the board as illustrated below. Each player rolls a single die. The player rolling the highest number goes first, and decides which side of the board and color of pieces to play. This player moves first, combining the two single throws of the players as the first move. Throughout the rest of the game, each player throws the dice and moves accordingly in alternating turns.
- The two numbers of the two dice thrown on each turn may be used separately to move two pieces or combined to move one piece. A player's piece may be moved to any point except one already occupied by two or more of the opponent's pieces. When a player has two or more pieces on the point, this is called 'making a point'.

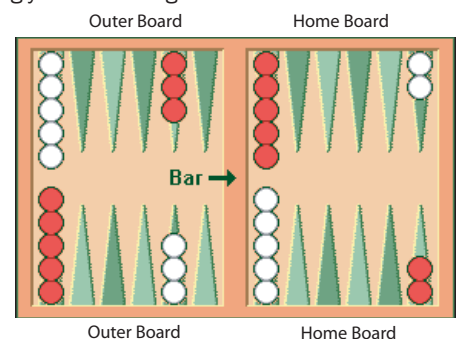

## GAME RULES (cont.)

- The opponent is barred from the landing on that point. If a player throws a pair, the player is allowed to move double the number thrown, the player may use the four numbers in any combination. A player must always use both numbers thrown whenever possible, but if only one of the numbers can be used, and there is a choice, the highest number must always be used.
- The two players move their pieces on opposite directions for example, white would move from black's home board towards white's home board. When all pieces are in a player's home board then the player may begin to 'bear off'.

### TO PLAY:

- A single piece occupying a point is a blot. If an opponent lands on a blot, the piece is removed from the board and placed on the 'bar', where it remains until it can be entered into the opponent's inner board. Pieces from the bar must be re-entered before any other moves are made. A piece may enter the board on points of the same number as shown on the dice. For example, if a 'five' and a "three" are thrown, a piece may be entered on a five point or a three point in the opponents inner board. If a point is 'made' by two or more opponent's pieces, a player may not enter on that point. If all of an opponent's inner-board points are made, the player forfeits that turn until the opponent's play opens up the inner board and makes entry possible. A player may land on two or more blots in the same throw. The player has a choice of landing on a blot or not unless no other move is possible.

### TO BEAR OFF:

- A player bears off by rolling a number that corresponds to the point on which the piece resides, and then removing that piece from the board. Thus rolling a 6 permits the player to remove a checker from the six point. If there is no piece on the point indicated by the roll, the player must remove one piece from the highest numbered point on which one of this pieces resides. A player is under no obligation to bear off if he can make a legal move (i.e. moving a piece closer to the end within the home board). If a piece is hit during the bear-off process, the player must bring that piece back to his home board before continuing to bear off.

### TO WIN:

- The winner may be determined in the following manner:  
A 'single game' – if the opponent has borne off at least one piece and has no pieces in the winner's inner board.  
A 'double game' or 'gammon' – if the opponent has not borne off any pieces.  
A 'triple game' or 'backgammon' – if the opponent has not borne off any pieces and has at least one piece still on the bar or in the winner's inner board.

## BOWLING:

---

- A game of American ten pins consists of ten frames. A player delivers two balls in each of the first nine frames unless a strike is scored. In the tenth frame, a player delivers three balls only if a strike or spare is scored. Every frame must be completed by each player bowling in regular order.
- **KEEPING SCORE** – Except when a strike is scored, the number of pins knocked down by the player's first delivery is to be marked next to the small square in the upper right hand corner of that frame, and the number of pins knocked down by the player's second delivery is to be marked inside the small square. If none of the standing pins are knocked down by the second delivery in a frame, the score sheet shall be marked with a (-). The count for the two deliveries in the frame shall be recorded immediately.
- **STRIKE** – A strike is made when the full setup of ten pins is knocked down with the first deliver in the frame. It is marked by an (x) in the small square in the upper right-hand corner of the frame when it was made. The count for one strike is 10 plus the number of pins knocked down on the player's next two deliveries.
- **DOUBLE** – Two consecutive strikes is a double. The count for the first strike is 20 plus the number of points knocked down with the first delivery following the second strike.
- **TRIPLE OR TURKEY** – Three successive strikes is a triple or turkey. The count for the first strike is 30. To bowl the maximum score of 300, the player must bowl 12 strikes in succession.
- **SPARE** – A spare is made when the second delivery knocked down all the standing pins, and the score sheet shall be marked with a (/). The count of a spare is 10 plus the pins knocked down in the following delivery.

## SHUFFLEBOARD:

---

- Shuffleboard can be played two ways: Singles and doubles. For singles, we recommend one scoring count. We also recommend, if space is limited, that you play doubles with one scoring court.
- Toss a coin to determine the choice of color.
- To start a game, the red disc is shot first. Play alternates – red then blue – until all discs are shot. Red shall always be played from the right side of the head of the court, and the left side of the foot of the court.
  - IN SINGLES*, after all discs are played, constituting a half round, the players walk to the opposite end of the court and start play. In this case, the discs are picked up and play starts again.
  - IN DOUBLES*, after all discs are played at the head of the court, players at the foot of the court start play. In this case, play resumes at the head of the court again; red leading, blue following. Color lead does not change until both ends have been played (ONE ROUND).
- A game is considered on a 50, 75, or a 100 point basis.
- Players shall place their three (3) discs within and not touching lines of their respective half of the -10 area. **Penalty is -5.** Penalty is not applied to a player until he has played a disc.
  - \* The disc must be played from clear within the respective half of the 10-off area.
  - \* If the disc played touches the front or back lines – penalty is -5.
  - \* If the disc played touches the side line, or triangle – penalty is -10, the offender's disc removed, and the opponent is credited with any disc displaced.
  - \* All displaced discs shall be removed from the court immediately after the scoring of the opponent's displaced discs.
  - \* No penalty is inflicted if the disc being played STARTED in clear, and touched or crossed the separation triangle. Discs may be moved and played from any spot within the respective -10 area. A disc is played when it leaves the starting area, except when jockeying.
- No hesitation shot is allowed. Forward motion of the disc must be continuous. **Penalty is -10**, the offender's disc is removed and the opponent is credited with a score of any of the discs displaced. All displaced discs shall be removed from the court immediately after the scoring of the opponent's displaced discs.
- No hook shall be allowed. The shot must be delivered in a straight line with continuous forward motion of the disc. **Penalty is -10**, the offender's disc is removed and the opponent is credited with the score of any of discs displaced. All displaced discs shall be removed from the court immediately after the scoring of the opponent's displaced discs.
- Players shall not step on or over the baseline of the court, or the extension of the baseline, except to gather and place their discs. **Penalty is -5** for this offense when not in the act of executing a shot. Players must not touch a foot, hand, knee, or any other part of their body to the court on or over the baseline or extension of the baseline at any time while executing a shot; **penalty is -10.**
- Players shall not stand in the way of, or have a cue in the way of, or interfere with the opponent while he is executing a play. **Penalty is -5.**
- Player shall not touch live discs at any time. **Penalty is -5.**
- A disc or discs returning or remaining on the player area of the court, after having struck any object outside the playing area, shall be removed before further play. It is called a dead disc.
- If a dead disc rebounds and touches a live disc, or causes another dead disc to touch a live disc, the half-round shall be played over. EXCEPT if it was the result of the last disc (the 8th disc) played in the half-round. In this case the half-round is not replayed, and any score that was on the board immediately before the rebound shall count.
- A disc that stops in the area between the farthest deadline and the starting area is dead and shall be removed before further play. If the disc is touching the farthest deadline it is in play.
- Any disc that clearly leaves the court beyond the farthest baseline, or goes off the side of the court is a dead disc.
- A disc that is leaning over the edge of the court and touching the alley shall be immediately removed.
- Any player shooting before the opponent's disc comes to rest; **penalty is -10.** The offender's disc is removed, and the opponent is credited with any of his discs displaced. All displaced discs shall be removed from the court immediately after the scoring of opponent's displaced discs.

# GAME RULES (cont.)

## BILLIARDS (8 BALL):

---

### OBJECT OF THE GAME:

- 8 Ball is a simple game enjoyed by players of all skill levels. It is a Called Shot Game, meaning that the players must announce their intended shot in advance in order for it to count. In 8 Ball, one player shoots at solid balls (numbers 1 through 7), while the opponent shoots at striped balls (numbers 9 through 15). The player who pockets his or her ball groups first and then sinks the 8 Ball is the winner.

### THE BREAK:

- The balls are racked in the triangle. A flip of a coin determines which player gets to break. In subsequent games, the loser of the previous game gets to break. The cue ball must be placed behind the head string and the shooter must either: (a) pocket a ball, or (b) drive four balls to the rails. If the shooter fails to make a legal break, the opponent has the option of accepting the balls in the position or re-racking the balls and shooting the opening break again.
- If any balls are pocketed on the break: the shooter stays on the table, however the table is still open, meaning that the choice of the stripes or solids is not yet determined. The choice of stripes or solids is determined by the first called shot made after the break.
- If the 8-ball is pocketed on the break: the shooter stays on the table with the option of spotting the 8-ball and continuing play, or re-racking the balls and breaking again.
- If the shooter scratches on the break (cue ball is pocketed): **(a)** all balls pocketed remain pocketed, except the 8 ball which is spotted, **(b)** the table is open, **(c)** the opposing player has the cue ball in hand and may place it anywhere behind the head string and shoot at any ball that is not behind the head string.

### PLAYING THE GAME:

- After the break, regardless of whether any balls were pocketed on the break, the table is Open, with the choice of stripes or solids determined by the next legally pocketed ball.
- In the course of play, a shooter must call each shot in advance by indicating the ball to be made and the pocket into which it will be made. It is not necessary to indicate details such as cushions, banks, caroms, etc.; failure to make the shot as called results in a loss of turn. If the shot is made as called, then any other balls pocketed remain pocketed. However, if the called shot is not made and any other balls are pocketed, then the shooter's ball(s) that were pocketed would be spotted and any of the opponent's balls would remain pocketed.
- In order to execute a Legal Shot, the first ball hit must be one of the balls in the shooter's group (stripes or solids) and the object ball must be pocketed or the cue ball or any object ball must come into contact with a rail. (Noted: It is legal for the shooter to bank the cue ball off a rail before hitting the object ball.)
- A player who legally pockets a ball continues play until missing or committing a Foul. Once a player's ball group (stripes or solids) is pocketed, the player may play the 8 Ball. Again, the player must clearly indicate the intended pocket, even if it appears obvious. A player who legally pockets all of his ball group and the 8 Ball is the winner.
- **FOULS:**
  1. Failure to execute a legal shot as defined above.
  2. A scratch shot (shooting the cue ball into a pocket or off the table)
  3. Moving or touching any ball by means other than legal play.
  4. Shooting an intentional jump shot over another ball by scooping the cue stick under the cue ball. A jump shot executed by striking the cue ball above center is legal.
  5. Using the 8 Ball first in a combination shot when the table is not open.

### FOUL PENALTY:

Opposing player gets "cue ball in hand". This means that the player can place the cue ball anywhere on the table (does not have to be behind the head string except on the opening break).

### SPOTTING BALLS:

Whenever an object is to be spotted, the object ball is spotted on the long string as close to the foot spot as possible.

### LOSS OF GAME:

A player committing any of the following infractions loses the game:

1. Fouls when pocketing the 8 Ball.
2. Pockets the 8 Ball on the same stroke as the last of his group of balls.
3. Scratches when the 8 Ball is his legal object ball.
4. Jumps the 8 Ball off the table at any time.
5. Pockets the 8 Ball in a pocket other than the one designated.
6. Pockets the 8 Ball when it is not the legal object ball (except on the break).

## **BILLIARDS (9 BALL):**

---

- **OBJECT OF THE GAME:**

Nine-Ball is a popular game enjoyed by players of all skill levels. In 9 Ball, the shooter must make contact with the lowest numbered ball first. The player who sinks the 9-ball is the winner.

- **THE BREAK:**

Balls numbered 1 through 9 are racked in a “diamond” shaped with the 1 Ball at the top of the diamond and on the foot spot and the 9 Ball in the center. The cue ball must be placed behind the head string and the shooter must make contact with the 1 Ball first and either: (a) pockets a ball, or (b) drives four balls to the rails. If the shooter fails to make a legal break, the opponent has the option of accepting the balls in this position or re-racking the balls and shooting the opening break again. If the cue ball is scratched on the break, the incoming player may not play a “Push Out” (see PUSH OUT), but places the “cue ball in hand” anywhere on the table.

- **PLAYING THE GAME:**

After the break, the next shot may be played as a “Push Out”, or, if the breaker pockets one or more balls, he continues to shoot until he misses, fouls, or wins the game. Once a player misses or fouls, the opponent begins to shoot until missing, committing a foul, or winning. The game ends when a 9 Ball is pocketed on a legal shot.

- **PUSH OUT:**

The player shooting immediately following a legal break may play a Push Out in an attempt to move the cue ball into a better position. In a Push Out, a ball does not have to make contact with any ball or rail and is not considered a foul unless other foul rules apply. The player must announce the intention of playing a Push Out before the shot, or it is considered normal play. Any ball pocketed on a Push does not count and remains pocketed (except the 9 Ball). Following a Push Out, the incoming player: a) must shoot from that position or b) may pass the shot back to the other player.

- **FOULS:**

1. Failure to execute a legal shot as defined.
2. Failure to make first contact with the lowest numbered ball on the table.
3. A scratch shot (shooting the cue ball into a pocket or off the table)
4. Moving or touching any ball by means other than legal play.
5. When the object ball is not pocketed, failure to drive the ball to a rail after the cue ball has made contact with the object ball.
6. Shooting an intentional jump shot over another ball by scooping the cue stick under the cue ball. A jump shot executed by striking the cue ball above center is legal.
7. Driving any ball off of the table. The object balls are not re-spotted (except the 9 Ball)

- **FOUL PENALTY:**

Opposing player gets “cue ball in hand”. This means that the player can place the cue ball anywhere on the table. Balls pocketed on the foul are NOT re-spotted (except the 9 Ball). Any player that commits a foul three consecutive times on three successive shots without making a legal shot in between loses the game.

## LIMITED WARRANTY

We warrant to the original consumer that the table is to be free from defects in workmanship or materials under normal use and conditions for a period of ninety (90) days from the date of original purchase.

## PRODUCT REGISTRATION

Your table should be registered within 30 days from the date of original purchase. Registration may be submitted through the following means:

**Phone:** 1-800-526-0244  
**Website:** www.sportcraft.com  
**Mail:** Sportcraft, Ltd.  
**Attn:** Product Registration  
313 Waterloo Valley Road  
Budd Lake, NJ 07828 USA

## WARRANTY COVERAGE

Except as provided below, this Limited Warranty covers all defects in materials and workmanship in a residential, single-family home environment. This Warranty is void if the table is:

- damaged through unreasonable usage, negligence, misuse, abuse, acts of nature, transportation or third-party freight handling damage, or by accident
- used in commercial applications (store display models, etc.) or rentals
- improper service

What is NOT covered: accessories, cosmetic parts (graphics, laminates, polish) and other items that wear out with normal usage.

## WARRANTY CLAIMS

If during the 90 day Limited Warranty period, any part or component of the table is found by Sportcraft, Ltd. to be defective, we will replace that part or component without charge (including non-expedited shipping and handling). Proof of purchase and pictures of defects may be required for certain claims.

For all claims, please have receipt and model number readily available when contacting our Customer Relations Department:

**Phone:** 1-800-526-0244 (Mon-Fri, 9:00a.m. - 5:00p.m. EST)  
**Online:** www.sportcraft.com  
**Mail:** Sportcraft, Ltd.  
**Attn:** Customer Service  
313 Waterloo Valley Road  
Budd Lake, NJ 07828 USA

This warranty gives you specific legal rights, though you may have other rights that vary by state.

Attention: We need your help! Our goal is to produce the finest product possible. Unfortunately, there are times when a product malfunctions or a part breaks. We are happy to replace the part, and this can be done by ordering from our web site or by calling our toll free number. However, we also want to know why the part malfunctioned or broke so that we can improve it in the future. To that end, please take a picture of the broken part and email it to us a photos@sportcraft.com. The email should include your name, address, phone number, and model number. We appreciate your assistance.

Send this form along with your check or money order payable to:

Name: \_\_\_\_\_ Date: \_\_\_\_\_

Address: \_\_\_\_\_ Phone Number: \_\_\_\_\_

City: \_\_\_\_\_ State: \_\_\_\_\_ Zip Code: \_\_\_\_\_

**Sportcessories**

313 Waterloo Valley Rd  
Budd Lake, NJ 07828  
www.sportcraft.com

REF	QTY ORDERED	PART #	DESCRIPTION	Unit Price	Total Amount
1		9-3-35-7X4SS034	SIDE PANEL, SOCCER, X7535	\$12.00	
2		9-3-35-7X4SS035	END PANEL, SOCCER, X7535	\$12.00	
3		9-3-35-7X4SS036	PLAYING SURFACE, TBL. SOCCER, GREEN	\$15.00	
4		9-3-35-7X4SS037	SUPPORT BRACE, FOR FIELD	\$8.00	
5		9-3-35-7X4SS038	LEG PANEL A, X7535	\$10.00	
6		9-3-35-7X4SS039	LEG PANEL B, X7535	\$10.00	
7		9-3-35-7X4SS040	LEG PANEL C, X7535	\$10.00	
8		9-3-35-7X4SS041	LEG BASE, X7535	\$4.00	
9		9-3-35-7X4SS042	LEG CAP, X7535	\$4.00	
10		9-3-35-7X4SS043	END RAIL, BASE, X7535	\$10.00	
11		9-3-35-7X4SS044	BALL CATCHER, X7535	\$4.00	
12		9-3-35-7X4SS045	CABINET, BILLIARDS/HOCKEY, 54 IN, X7535		
13		9-3-35-7X4SS046	DRAWER DOOR, X5735	\$3.00	
14		9-3-35-7X4SS047	SIDE SUPPORT, LOWER, X7535	\$8.00	
15		9-3-35-7X4SS048	SIDE SUPPORT, UPPER, X7535	\$8.00	
16		9-3-35-7X4SS049	END PANEL, INSIDE-R, X7535	\$15.00	
17		9-3-35-7X4SS050	END PANEL, INSIDE-L, X7535	\$15.00	
18		9-3-35-7X4SS051	END PANEL, OUTSIDE, X7535	\$15.00	
19		9-3-35-7X4SS052	END RAIL, TOP, X7535	\$8.00	
20		9-3-35-7X4SS053	SHELF, X7535	\$10.00	
21		9-3-22-895RP18	BOWLING/SHUFFLE/BACKGAMMON/SURFACE	\$6.00	
22		9-3-22-698K	BUMPER, BLACK.	\$0.50	
23		9-3-22-853RP27	WASHER, 5/8" X 1-1/2", STEEL	\$0.50	
24		9-3-22-853RP28	WASHER, 5/8" X 1-1/2", PLASTIC	\$0.50	
25		9-3-22-767RP29	ROD END CAP, BLACK.	\$0.50	
26		9-3-22-900M	BALL ENTRY CUP, BLACK.	\$4.00	
27		9-3-22-853RP25	PLAYER, ROBOT STYLE, MAROON.	\$4.00	
28		9-3-22-9000a	PLAYER, ROBOT STYLE, CREAM.	\$4.00	
29		9-3-35-7X1SS024	ROD, 5-PLAYER, HOLLOW, CHROME,40.25 IN	\$11.00	
30		9-3-35-7X1SS022	ROD, 2-PLAYER, HOLLOW, CHROME,49.25 IN	\$13.00	
31		9-3-35-7X1SS023	ROD, 3-PLAYER, HOLLOW, CHROME,44.50 IN	\$12.00	
32		9-3-22-895RP81	CABINET ROD, 1/4", 24" LONG	\$3.00	

\*\*NOTE: PRICES IN US DOLLARS AND SUBJECT TO CHANGE WITHOUT NOTICE.

Attention: We need your help! Our goal is to produce the finest product possible. Unfortunately, there are times when a product malfunctions or a part breaks. We are happy to replace the part, and this can be done by ordering from our web site or by calling our toll free number. However, we also want to know why the part malfunctioned or broke so that we can improve it in the future. To that end, please take a picture of the broken part and email it to us a photos@sportcraft.com. The email should include your name, address, phone number, and model number. We appreciate your assistance.

Send this form along with your check or money order payable to:

Name: \_\_\_\_\_ Date: \_\_\_\_\_  
Address: \_\_\_\_\_ Phone Number: \_\_\_\_\_  
City: \_\_\_\_\_ State: \_\_\_\_\_ Zip Code: \_\_\_\_\_

**Sportcessories**  
313 Waterloo Valley Rd  
Budd Lake, NJ 07828  
www.sportcraft.com

REF	QTY ORDERED	PART #	DESCRIPTION	Unit Price	Total Amount
33		9-3-22-763RP33	RAMP, SIDE, MAROON.	\$4.00	
34		9-3-22-763RP32	RAMP, LEFT END, MAROON.	\$2.00	
35		9-3-22-763RP31	RAMP, RIGHT END, MAROON.	\$2.00	
36		9-3-36-7X3SS026	LOCK BOLT, X7535	\$0.50	
37		9-3-22-853RP39	DRAWER HANDLE, X6535.	\$1.00	
38		9-3-22-853RP46	BOLT, 1/4" x 2-1/2".	\$0.50	
39		9-3-36-7X3SS025	SCREW, 1-1/4", FLAT	\$0.50	
40		9-3-22-425RP007	SCREW, 1-3/4".	\$0.50	
41		9-3-22-853RP20	SCREW, 1/2" PHILLIPS HEAD.	\$0.50	
42		9-3-22-924RP15	SCREW, 1/2".	\$0.50	
43		9-3-36-7X3SS024	BOLT, 5/8"	\$0.50	
44		9-3-36-7X3SS023	BOLT, 1/8"	\$0.50	
45		9-3-22-907RP28	SCREW, #8 X 1-1/8".	\$0.50	
46		9-3-22-767RP24	LOCK NUT, 8#.	\$0.50	
47		9-3-22-908RP27	LOCK NUT, 1/4".	\$0.50	
48		9-3-22-568RP022	LOCK NUT, 5/16".	\$0.50	
49		9-3-22-767RP15	WASHER, 1/4".	\$0.50	
50		9-3-22-425RP009	WASHER, 5/16".	\$0.50	
51		9-3-36-7X3SS022	BOLT, STOPPER BOLT	\$0.50	
52		9-3-22-853RP29	HANDLE, DK MAHOGANY, WOOD.	\$3.00	
53		9-3-22-853RP65	PUCK, 2-1/2", 11.2g, RED.	\$1.50	
54		9-3-22-425RP016	FELT, GREEN.	\$0.50	
55		9-3-22-425RP015	PUSHER, RED, PLASTIC, 96MM	\$1.25	
56		9-3-22-424RP032	SOCCER BALL.	\$1.00	
57		9-3-22-853RP63	BILLIARD CUE STICK, 36".	\$6.00	
58		9-3-22-425RP013	CHALK, BILLIARDS.	\$1.00	
59		9-3-22-853RP61	BILLIARD BALLS, SET, 1-1/2".	\$12.00	
60		9-3-22-853RP62	TRIANGLE, BILLIARDS, SMALL 7".	\$2.00	
61		9-3-22-853RP55	CARD DECK.	\$4.00	
62		9-3-22-853RP56	BOWLING BALL, MINI, RED.	\$2.00	
63		9-3-22-853RP57	BOWLING PIN, 6".	\$2.00	
64		9-3-22-853RP58	CHECKER SET / BACKGAMMON.	\$3.00	

\*\*NOTE: PRICES IN US DOLLARS AND SUBJECT TO CHANGE WITHOUT NOTICE.







**Sportcraft, Ltd.**  
313 Waterloo Valley Rd.  
Budd Lake, NJ 07828  
[www.sportcraft.com](http://www.sportcraft.com)  
1-800-526-0244  
1-973-347-1541 fax

**CLASSIC**  
**SPORT**®