

**SPEAKMAN COMPANY**  
**VS-2000-BP Installation, Maintenance & Operation Instructions**  
**ANYSTREAM 2000® SHOWERHEAD**

**DESCRIPTION**

Polished chrome plated ANYSTREAM 2000 hand held shower. Includes extra long six-foot reinforced hose and swivel ball bracket for shower arm mounting. Spray adjusting T-handle. 3-1/4" face. 5 self cleaning plunger nozzles resist scale build-up and provide 50 spray streams for a full body coverage pattern. Center core nozzle delivers nine vibra-massage jets. Combination spray included. Water conserving pressure compensating AUTOFLO® device reduces flow to 2.5 GPM/9.46LPM maximum, to meet existing ANSI A112.18.1M Standard. 1/2" NPSM inlet.

**SPECIFICATIONS**

SUPPLY INLET: 1/2" NPSM

FLOW RATE: 2.5 GPM/9.46 LPM MAX.

FLOW CONTROL: VARIABLE

SHIPPING WEIGHT: 1.43 LBS.

**OPTIONS**

**BB** Bright Brass Finish

**MH** Metal Hose

**WHT** White/Chrome Combination Finish

**INSTALLATION**

Install rubber washers in the ends of the hose. Turning in a clockwise direction, thread the hose swivel on to the hand held shower. Attach shower arm mount to shower arm. Connect hose to shower arm mount. Hand tighten firmly all connections. Turn the water supply on and check for leaks.

**OPERATION**

To adjust the spray pattern of the showerhead, simply rotate the handle to the desired spray (needle spray, gentle rain or vibra-massage).

**MAINTENANCE (CARE AND CLEANING)**

The gleaming finish of your SPEAKMAN ANYSTREAM 2000 showerhead can be cleaned by using mild soap and warm water. Dry immediately with a soft, clean cloth for best results. The flow control device limits water flow to 2.5 gallons per minute. The small orifices may become clogged with scale and other minerals found in potable water. To clean the flow regulator, simply remove the shower arm mount from the bent arm, pull out the rubber washer from the ball, dislodge the flow regulator and clean as necessary.

**ROUGH-IN MEASUREMENTS**

NOTE: ACCESSORIES NOT SHOWN

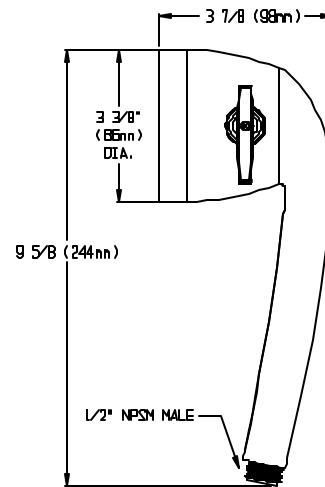
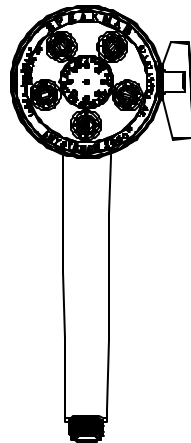
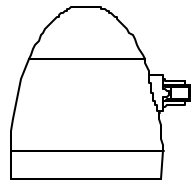

Product improvements may cause specification and dimensional changes without notice.



**SPEAKMAN COMPANY**  
The Difference Is The Experience  
P.O. Box 191, Wilmington, DE 19899  
Phone: 800-537-2107 Fax: 800-977-2747