



STYLE NO. CK9910











“DAVENPORT”

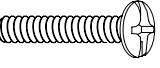

COCKTAIL TABLE

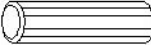
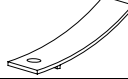
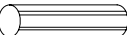
SOUTHERN ENTERPRISES INC.

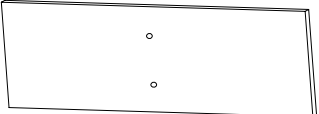
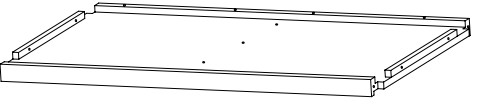
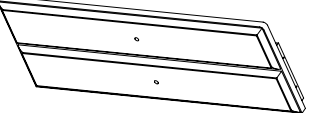
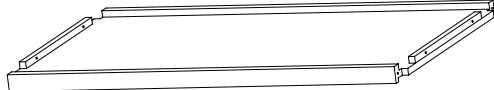
RELAX...If you can follow a few easy, step-by-step directions in order .YOU CAN ASSEMBLE THIS ITEM.

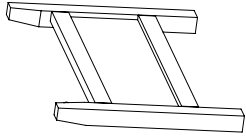
PLEASE FIND HARDWARE IN RED POLYBAG BEFORE DISCARDING PACKING MATERIAL.

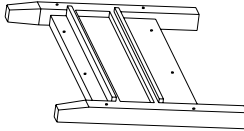
HARDWARE LIST			
(1) METAL KNOBS	8PCS	(7) COVERS	8PCS
			
(2) SMALL MACHINE SCREWS	8PCS	(8) CAM-LOCKS	8PCS
 Ø5/32”X3/4”			
(3) LARGE WOOD SCREWS	16PCS	(9) LARGE MACHINE SCREWS	8PCS
 Ø4X19mm		 Ø1/4”X1-1/4”	
(4) CAM-BOLTS	8PCS	(10) WASHERS	8PCS
			
(5) LARGE WOOD DOWELS	14PCS	(11) DRAWER STOPPER	2PCS
 Ø8X30mm			
(6) SMALL WOOD DOWELS	8PCS	(12) SMALL WOOD SCREWS	2PCS
 Ø6x30mm		 Ø3X12mm	
PARTS LIST			
(A) FAUX DRAWER FRONT PANEL	2PCS	(H) SHELF	1PC
			
(B) DRAWER FRONT PANEL	2PCS	(I) BOTTOM PANEL	1PC
			
(C) DRAWER RIGHT SIDE PANEL	2PCS	(J) LEFT SIDE FRAME	1PC
			

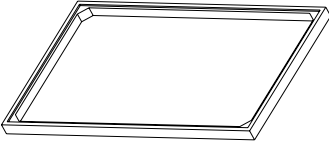
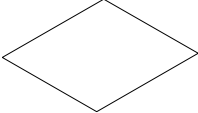
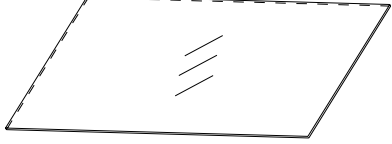
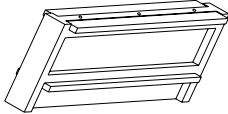
(D) DRAWER BACK PANEL 	2PCS	(K) RIGHT SIDE FRAME 	1PC
(E) DRAWER LEFT SIDE PANEL 	2PCS	(L) TOP FRAME 	1PC
(F) DRAWER BOTTOM PANEL 	2PCS	(M) GLASS TOP 	1PC
(G) DIVIDER 	1PC		

ASSEMBLY INSTRUCTIONS

1. SELECT A SMOOTH, SOFT SURFACE TO PREVENT SCRATCHING FINISH.
2. YOU MAY NEED A PHILLIPS SCREWDRIVER.
3. INSERT SMALL MACHINE SCREWS (2) THROUGH PREDRILLED HOLES ON BACK OF DRAWER FRONT PANEL (B) AND TIGHTEN INTO METAL KNOBS (1). INSERT LARGE WOOD SCREWS (3) THROUGH PREDRILLED HOLES ON OUTSIDE OF DRAWER RIGHT SIDE PANEL (C) AND TIGHTEN INTO CORRESPONDING HOLES ON ENDS OF DRAWER FRONT AND BACK PANELS (B, D). SLIDE DRAWER BOTTOM PANEL (F) INTO GROOVES ON INSIDE OF DRAWER FRONT AND BACK PANELS (B, D) AND ALIGN WITH THE GROOVE ON DRAWER RIGHT SIDE PANEL (C). PERFORM THE SAME WAY TO ASSEMBLE DRAWER LEFT SIDE PANEL (E). AND ASSEMBLE ANOTHER DRAWER IN SAME MANNER. (AS SHOWN IN FIGURE 1)

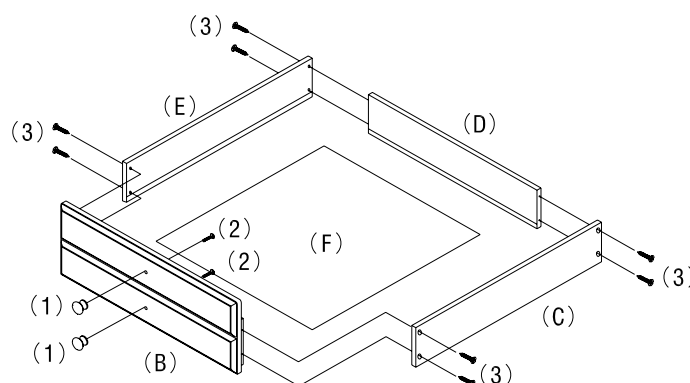

FIGURE 1

4. TIGHTEN SMALL WOOD SCREWS (12) THROUGH DRAWER STOPPER (11) INTO PREDRILLED HOLES ON BOTTOM PANEL (I). INSERT SMALL MACHINE SCREWS (2) THROUGH PREDRILLED HOLES ON FAUX DRAWER FRONT PANELS (A) AND TIGHTEN INTO METAL KNOBS (1). (AS SHOWN IN FIGURE 2 & 3)

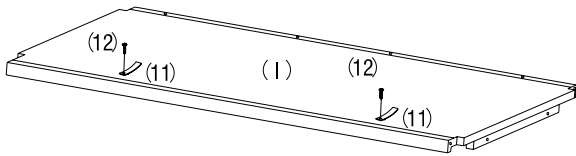

FIGURE 2

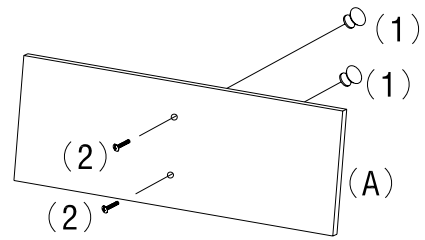

FIGURE 3

5. INSERT CAM-BOLTS (4), LARGE WOOD DOWELS (5) INTO PREDRILLED HOLES ON SHELF (H) AND FIT INTO CORRESPONDING HOLES ON EDGE OF DIVIDER (G). INSERT CAM-LOCKS (8) INTO LARGE HOLES ON DIVIDER (G) WITH ARROW FACING TOWARDS HOLE. ROTATE CAM-LOCKS (8) CLOCKWISE TO SECURE CAM-BOLTS (4). PUSH COVERS (7) INTO CAM-LOCKS (8). INSERT SMALL WOOD DOWELS (6) INTO PREDRILLED HOLES ON FAUX DRAWER FRONT PANELS (A) AND FIT INTO CORRESPONDING HOLES ON SHELF (H). ASSEMBLE BOTTOM PANEL (I) IN SAME MANNER. (AS SHOWN IN FIGURE 4 & 5)

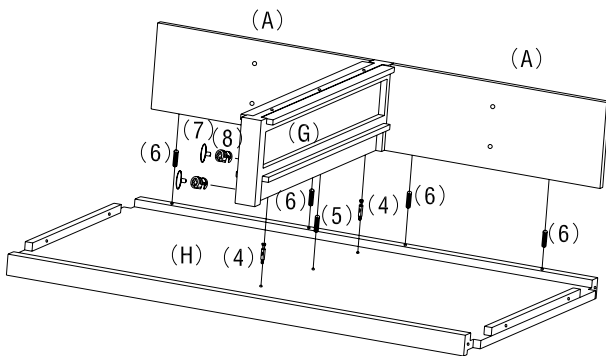

FIGURE 4

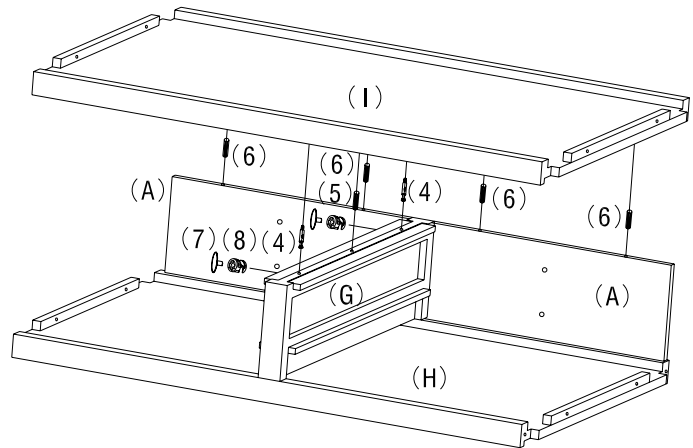

FIGURE 5

6. INSERT LARGE WOOD DOWELS (5) INTO PREDRILLED HOLES ON SIDE FRAMES (J, K) AND FIT INTO CORRESPONDING HOLES ON ENDS OF PARTS (H, I). INSERT LARGE MACHINE SCREWS (9) THROUGH WASHERS (10), PREDRILLED HOLES ON ENDS OF PARTS (H, I) AND TIGHTEN INTO PRETHREADED HOLES ON SIDE FRAMES (J, K). (AS SHOWN IN FIGURE 6)

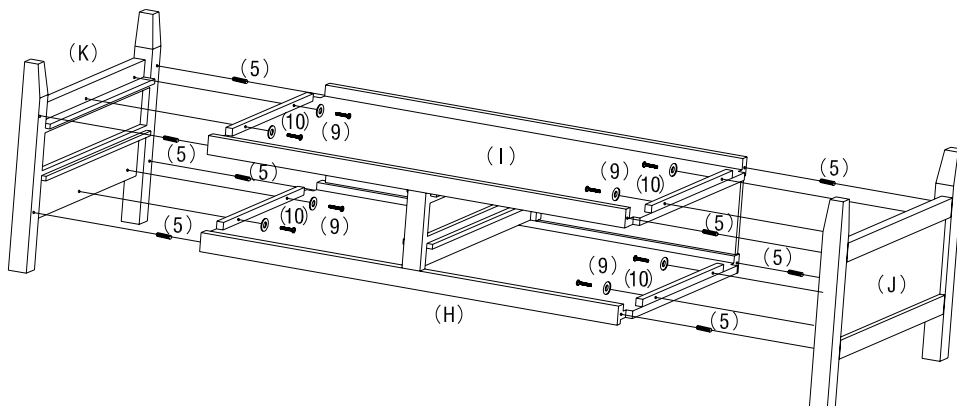

FIGURE 6

- UPRIGHT THE ABOVE UNIT, INSERT CAM-BOLTS (4), LARGE WOOD DOWELS (5) INTO PREDRILLED HOLES ON TOP FRAME (L) AND FIT INTO CORRESPONDING HOLES ON TOP OF SIDE FRAMES (J, K). INSERT CAM-LOCKS (8) INTO LARGE HOLES ON SIDE FRAMES (J, K) WITH ARROW FACING TOWARDS HOLE. ROTATE CAM-LOCKS (8) CLOCKWISE TO SECURE CAM-BOLTS (4). PUSH COVERS (7) INTO CAM-LOCKS (8). (AS SHOWN IN FIGURE 7)

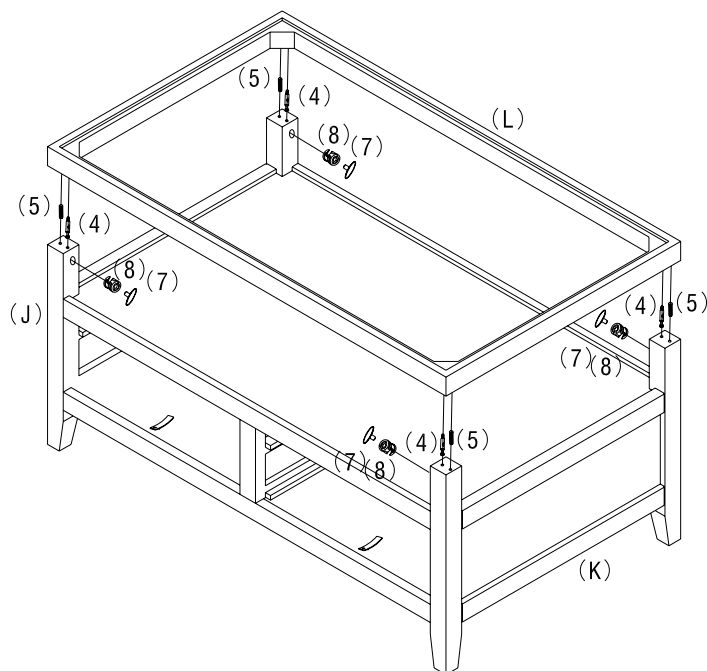

FIGURE 7

- INSERT THE ASSEMBLED DRAWERS INTO THE SPACE OF UNIT. AND PLACE THE GLASS TOP (M) ONTO SLOT OF TOP FRAME (L). (AS SHOWN IN FIGURE 8 & 9)

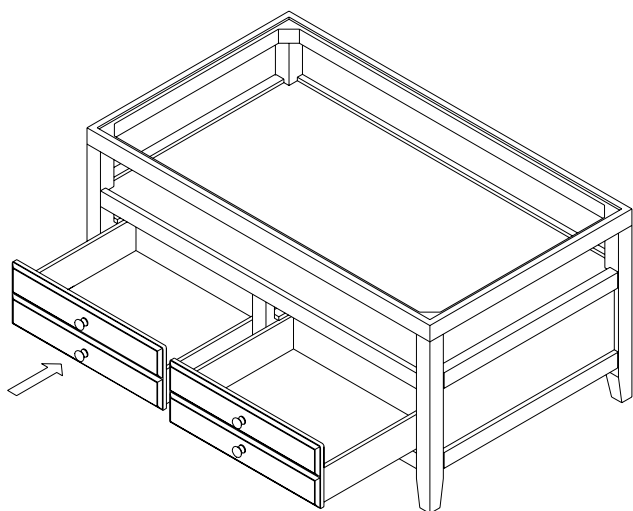

FIGURE 8

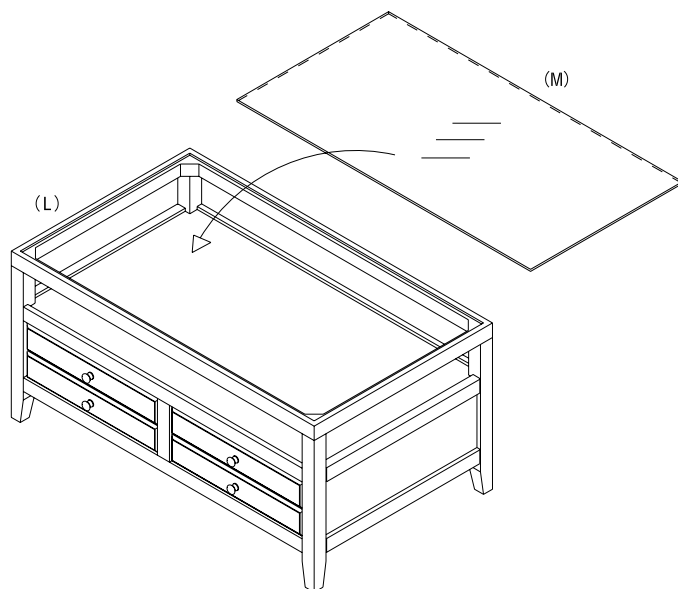



FIGURE 9

YOUR NEW “DAVENPORT” COCKTAIL TABLE IS FINISHED AND READY TO USE.

Please count, identify and compare parts and hardware list to be sure all parts are present. It may help to divide parts and label them to correspond with part list. Extra hardware may be included. If any items are missing, please contact our parts/service department at (800) 633-5096 or in Dallas (972) 869-0111/ 9am – 4pm Mon-Fri Central time. Missing or damaged hardware and/ or parts will be replaced free of charge. WE DO NOT SELL PARTS. WE DO NOT RECOMMEND MODIFYING PRODUCT(S) AND WE ARE NOT RESPONSIBLE FOR ANY DAMAGES DUE TO PRODUCT MODIFICATION(S). If this product has not been purchased from our retail affiliates (within 9 months), we are under no obligation to provide parts or replacement merchandise. Parts will not be available for items arriving fully assembled.

We will ship parts if available. This is not a warranty.

PARTS REPLACEMENT FORM			
STYLE NO: CK9910			
Customer Name	PARTS LETTER	PART DESCRIPTION	QUANTITY NEEDED
Street, City, State, Zip			
Phone#			
<div style="display: flex; justify-content: space-between; align-items: center;"> <div style="text-align: center;">  </div> <div style="width: 60%;"> <p style="margin: 0;">Please indicate where you purchased this item.</p> <p style="margin: 0;">Store/website/catalog</p> <p style="text-align: center; margin: 5px 0 0 100px;">/ /</p> <p style="margin: 0;">Please indicate color/size/style number</p> <p style="text-align: center; margin: 5px 0 0 100px;">/ /</p> </div> </div>			
SOUTHERN ENTERPRISES INC. P.O. Box 59996 Dallas, Texas 75229			