

User Information

Welcome to this exciting table soccer game with new, practical, and user-friendly features designed to enhance flexibility, safety, and functionality. This product comes with the basic game structure pre-installed and all playing figures pre-assembled on the rods. Please read all the important information in this instruction booklet before installing the game and follow the necessary procedures to ensure quality installation and product satisfaction.

All installations should be done by adults. Tools include wrenches, screwdriver, or pliers, easily found in common toolboxes. Install the legs or suction cups before installing the rods when the game structure is lighter and easier to move around without the rods on.

Leg Structure Installation (Full-size version)

- Refer to the drawing below. Connect the side support arms to the 4 legs as illustrated in the drawing. A nut has been mounted inside each leg, so just drive the screw inside and tighten it.

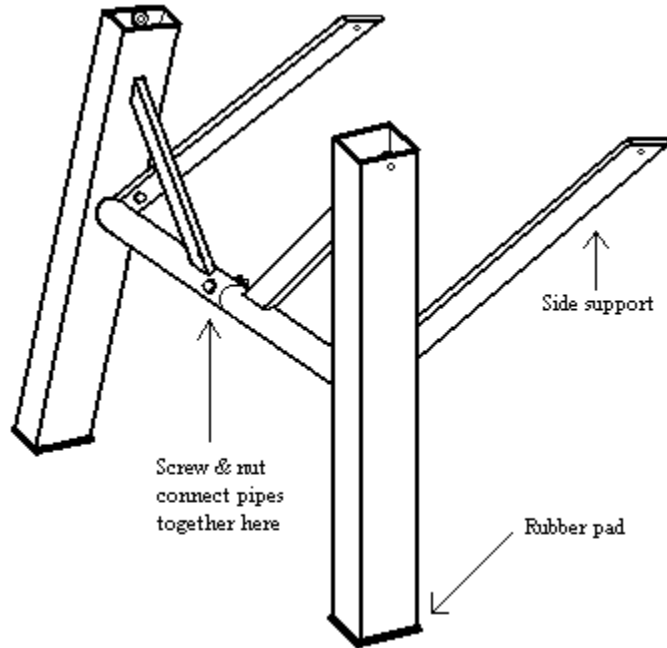

- These legs can be sand filled to increase weight (by 40 - 60 lb.) to provide extra stability to endure vigorous play, while shipping weight remains lowest possible to save consumers shipment costs. Filling sand or rice into the legs is recommended if the game table is used in public recreation centers. Use Dry Sand. Wet sand can make the inside of the legs rusty. Fill sand or rice after side support arms have been connected to the legs.
- Connect 2 legs with both side support arms pointing at the same direction. Join the round pipes by inserting one into the other. Put screw through the holes and fasten it with lock nut. Repeat the above process to connect the other pair of legs.
- Place the game table on a table of similar height to the legs. Pull one half of the game table length off the table and place a pair of legs under it. Mount the screws sideways. A nut is mounted inside

the leg for easy installation. Then connect the side support arms to the side walls. Fasten all screws and nuts.

Leg Structure Installation (Family Version with foldable metal legs)

The foldable metal legs consist of 2 Type **A** legs and 2 Type **B** legs. There are also 2 folding arms assemblies (triangle-shaped) marked "A" and "B" under the game table.

1. Lay the game structure upside down on a clean, flat and soft surface (carpet, bed, or sofa) where no sharp and hard objects are present to scratch the game surfaces.
2. Connect the 2 Type **A** legs together by joining the round pipes. Put screw through the holes on the pipes and fasten it with the lock nut.
3. Connect the 2 Type **B** legs the same way as above.
4. Mount each leg to the bottom of the side walls as illustrated below. Put Type **A** legs on the same side as Type **A** folding arms. Put Type **B** legs on the same side as Type **B** folding arms. Place the Protection Plate between the side wall and the leg with the arrow pointing to the center of the table (Protection Plate is not shown on the pictures in the packing). It **MUST** be installed this way to prevent possible finger injury when the folding legs open up or fall down by themselves. Then test to see if the legs can fold towards the center of the game table.

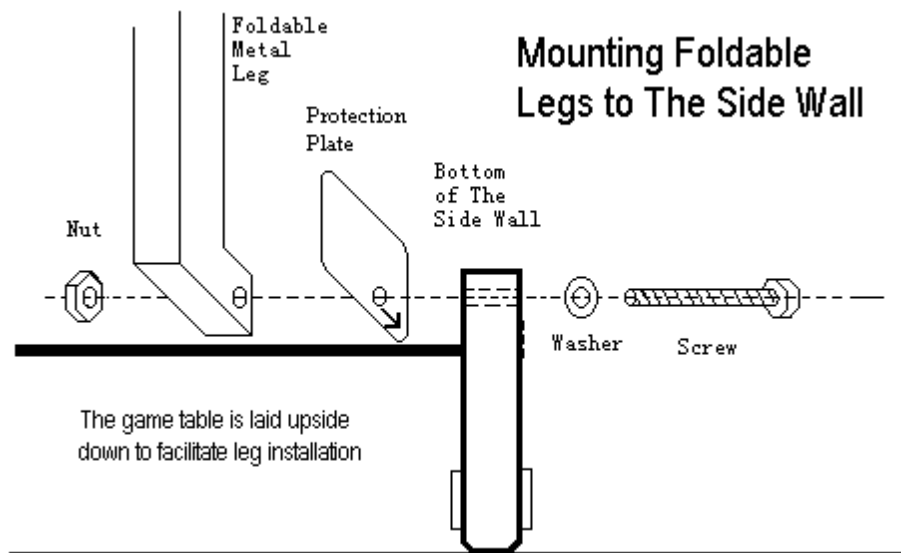

5. Connect Type **A** folding arms (triangle-shaped) to the Type **A** leg assembly. Fasten 2 lock nuts.
6. Connect Type **B** folding arms to the Type **B** leg assembly. Fasten 2 lock nuts.
7. Try out the folding motion and adjust nut tightness to a point where the legs can fold down and open up in a **CONTROLLED** manner. Loose nut connection can cause the legs to fold or open freely and may injure fingers if they happen to be in the way.
8. Turn the table up with all legs fully open. Make sure all folding arms are in position and the locking springs fall to the lower end to prevent the folding arms from folding while the game table is standing.
9. When folding the legs down for storage or carrying away, make sure legs on one side must fold down first to be in touch with and in parallel to the bottom of the side walls. Legs on the other side can then fall flat on the outside.

Rod Installation

Rod installation is easy and intended to be permanent. Therefore, please take special care to install each rod to the right position according to color and number of playing figures.

- Refer to the picture on the packing and study rod positions. Start with one goalkeeper rod (one-man rod). Install red goalkeeper next to the red scoreboard and the blue goalkeeper next to the blue scoreboard.
- With the inner rod inserted inside the playing rod and one spring on, slide the whole rod assembly through the nylon bearing on the side wall while holding the other end of the rod to avoid scratching the top of the opposite side wall.
- Push the plastic plug on the inner rod into the socket on the opposite side wall till it is fully locked tightly inside. The plug can be pulled out in case of wrong installation.
- Place the other spring on the rod with the bigger circle facing the side wall.
- To facilitate handle installation, **ALL HANDLES MUST BE WARMED UP FOR 10 MINUTES IN HOT WATER TO SOFTEN**. Use drops of water -- not lubricant of any kind -- to moisten the portion of the rod extending outside the side wall AND the inner surface of the hole in the handle to be installed. This is a **MUST** since lack of water lubrication may result in incomplete installation and will sacrifice rod handling. Push the handle fully onto the rod until it reaches the end of the hole (10cm or 4 inches deep). Indication that the handle is properly installed is that the spring flattens when the playing figure at the opposite end of the rod is just about to touch the plastic plug inserted in the opposite side wall. Moisture between the rod and the handle will dry up in 2 hours, and the handle will be tightly positioned on the rod. Check the handle position again in 2 hours since immediate playing after installation may cause the handle to slide back off its full inserted length when moisture still exists between the rod and the handle to make handle slipping easy.
- Repeat the above process with all the rods and inspect whether rod positions are right by comparing to the picture.

Rod Un-installation

Rods may need to be taken off the game table in some situations. These situations include removal of wrongly installed rods or need of re-packing for shipping.

- Pull the inner rod out of the socket on the side wall by grabbing it near the plastic plug. Turn back and forth while pulling. Use both hands if necessary. See below.

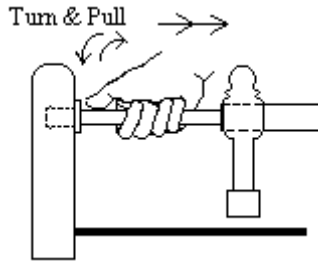

- Hold the free end of the rod just above the side wall to avoid scratching the aluminum surface. Grab the playing figures and pull the rod as indicated below.

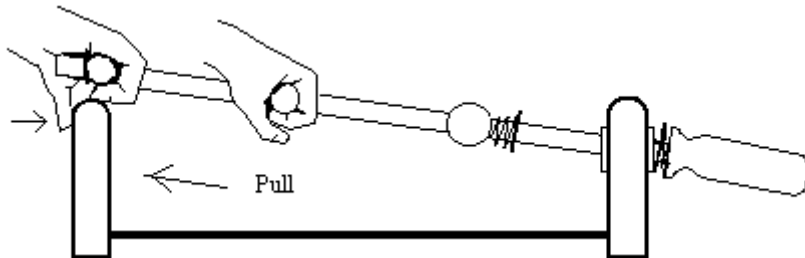

As the rod is pulled slowly but forcefully, grip of the handle on the rod becomes loose. If the handle is too tight on the rod, another person can hold the handle from the other side and try to turn and pull it to get it off. The handle and the spring eventually come off the rod.

Suction Cup Installation

If the end-user chooses to use the table-top setup instead of legs, the suction cups are a perfect solution. As an option, the suction cups and all fasteners are shipped with the game. Since pre-installed suction cups are easily distorted in shape due to excessive weight compiling during shipment and storage, the suction cups are supplied for installation by the end-user for best suction effect.

- Install the suction cups before installing the rods when the game structure is lighter and easier to handle without the rods on.
- Lay the game structure upside down on a clean and flat surface (carpet, bed, or sofa) where no sharp and hard objects are present to scratch the game surfaces.
- Insert the suction cup into the mounting hole in the bottom of the aluminum wall, turn back and forth while pushing if necessary to facilitate insertion till all the holes are aligned.
- Use screwdriver and wrench or pliers to fasten screw and nut. Hold the screwdriver steadily and drive forward slowly to avoid slipping or scratching the surface of the aluminum wall.
- After all the suction cups are installed, turn the game up and place it on a flat and smooth-surfaced table of proper height for rod installation.

Playing & Maintenance

This is a low-maintenance product. However, following the simple procedures below will ensure that the game functions in its best conditions.

- Basic rule of play: NO SPINNING. Avoid spinning of the rods in full circles since scoring by spinning is random (not skill) and illegal in this game and is a safety hazard.
- Lubrication of the rods is helpful and necessary. A thin layer of lubricant reduces friction and makes the rod handling and playing smoother. Certain oil-based lubricants work well and can be found in local hardware stores, such as Teflon or Silicone lubricants. Yet they often have an irritating and harmful smell for use inside the house. After numerous testing, **common hand cream or moisturizer often in the form of petroleum gel or jelly (such as Vaseline) has been found to be a cheap but very effective lubrication material that is easy to find and does not pollute the air inside the room.** Never use WD40 since it can damage the nylon bearing over time.
- The telescopic structure of the rods is adopted for safety considerations to prevent the rods from going through the side walls to poke players or onlookers (safety for children). Do not press the rods hard unnecessarily to cause bending.
- Hold the side walls to move the game. MUST NOT hold the rods to carry the game at any time.
- Do not spill liquid on the game table or expose the game to rain.
- Check the screws and nuts on the legs occasionally to make sure they are still tight in place.

Safety Considerations

- Always have an adult install the game, carry it, and set it up on legs.
- Use proper space around the game table for players to stand and move freely. Standing on feet with playing rods at waist height is the most comfortable playing position and is thus recommended.
- Do not leave the game on the ground since children may stumble over it or step on it.
- Do not spin the rods. Avoid putting hands inside the playing area during the game.
- Do not rush to retrieve the ball from the goal by putting hands inside it to reach the ball. Hands may get stuck, especially children's. Wait until the ball comes down the slope to the opening and use left index finger to retrieve it.
- Children aged under 5 are not recommended to play this game, or they should always be accompanied by an adult when playing.
- Prevent small children from playing under the game table.