

## ASSEMBLY/INSTALLATION INSTRUCTIONS

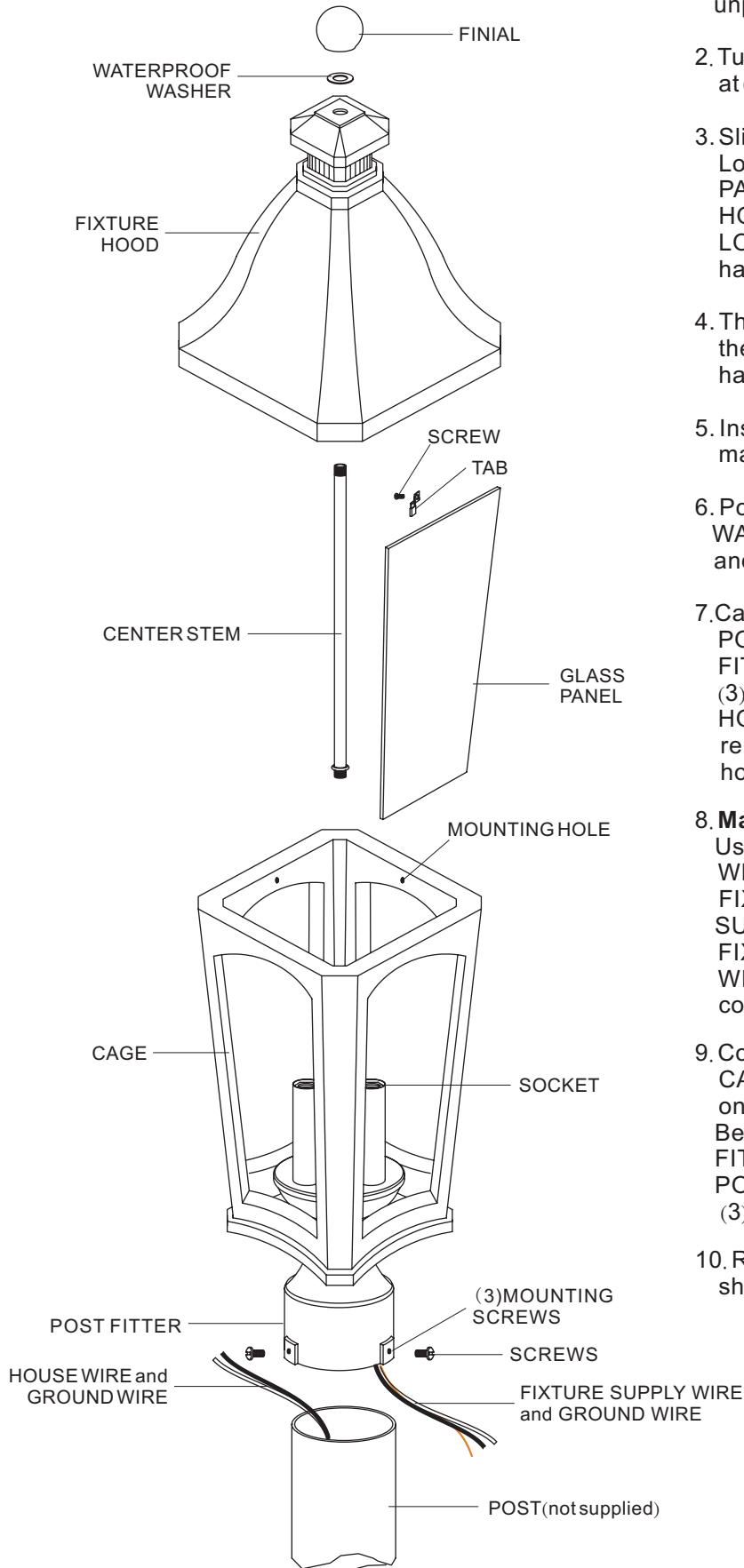

1. Before beginning the assembly/installation, carefully unpack and identify parts, referring to the illustration.
2. Turn the electrical power to the installation point OFF at circuit breaker.
3. Slip down the GLASS PANELS inside of the CAGE. Locate the TABS onto the top edge of the GLASS PANELS and align the hole to the MOUNTING HOLES on the top edge of the CAGE. Thread the LOCK SCREWS into the MOUNTING HOLES and hand tighten until snug to secure the panels.
4. Thread the beaded end of the CENTER STEM into the HEX COUPLING in the center of the CAGE and hand tighten until snug.
5. Install the correct bulbs referring to the fixture markings and/or labels for maximum wattage.
6. Position the FIXTURE HOOD, the WATERPROOF WASHER over the top end of the CENTER STEM and secure with the FINIAL. Hand tighten until snug.
7. Carefully fit the POST FITTER over the end of the POST (not supplied), making sure the POST FITTER is fully seated. Mark the drill point for the (3) MOUNTING SCREWS, using (3) MOUNTING HOLES as reference. After marking hole locations, remove FIXTURE from POST and drill 1/8" pilot holes for screws.
8. **Makin the wiring connections:**  
Using wire connectors (not supplied), connect the WHITE SUPPLY WIRE from the POST to the WHITE FIXTURE WIRE; connect the BLACK (or RED) SUPPLY WIRE from the POST to the BLACK FIXTURE WIRE. Connect the SUPPLY GROUND WIRE to the FIXTURE GROUND WIRE. Wrap each connection with approved electrical tape.
9. Coat the top 1" of the POST with CLEAR SILICONE CAULK (not supplied) and position the POST FITTER onto the POST.  
Be sure to seat it completely, aligning the holes in the FITTER with the 1/16" PILOT HOLES drilled into the POST. Secure the FIXTURE to POST with (3) MOUNTING SCREWS (supplied).
10. Restore power to installation point ON. Retain this sheet for future reference.

**IF IN DOUBT ABOUT ELECTRICAL INSTALLATION,  
CONSULT A LICENSED ELECTRICIAN!**