

CEILING INSTALLATION INSTRUCTIONS FOR FIXTURES WEIGHING OVER 45 LBS.

NOTE: DUE TO THE HANGING WEIGHT OF THIS FIXTURE, QUOIZEL HIGHLY RECOMMENDS YOU CONSULT A LICENSED ELECTRICIAN OR QUALIFIED CONTRACTOR FOR THIS INSTALLATION. QUOIZEL RECOMMENDS (2) PEOPLE FOR THIS INSTALLATION

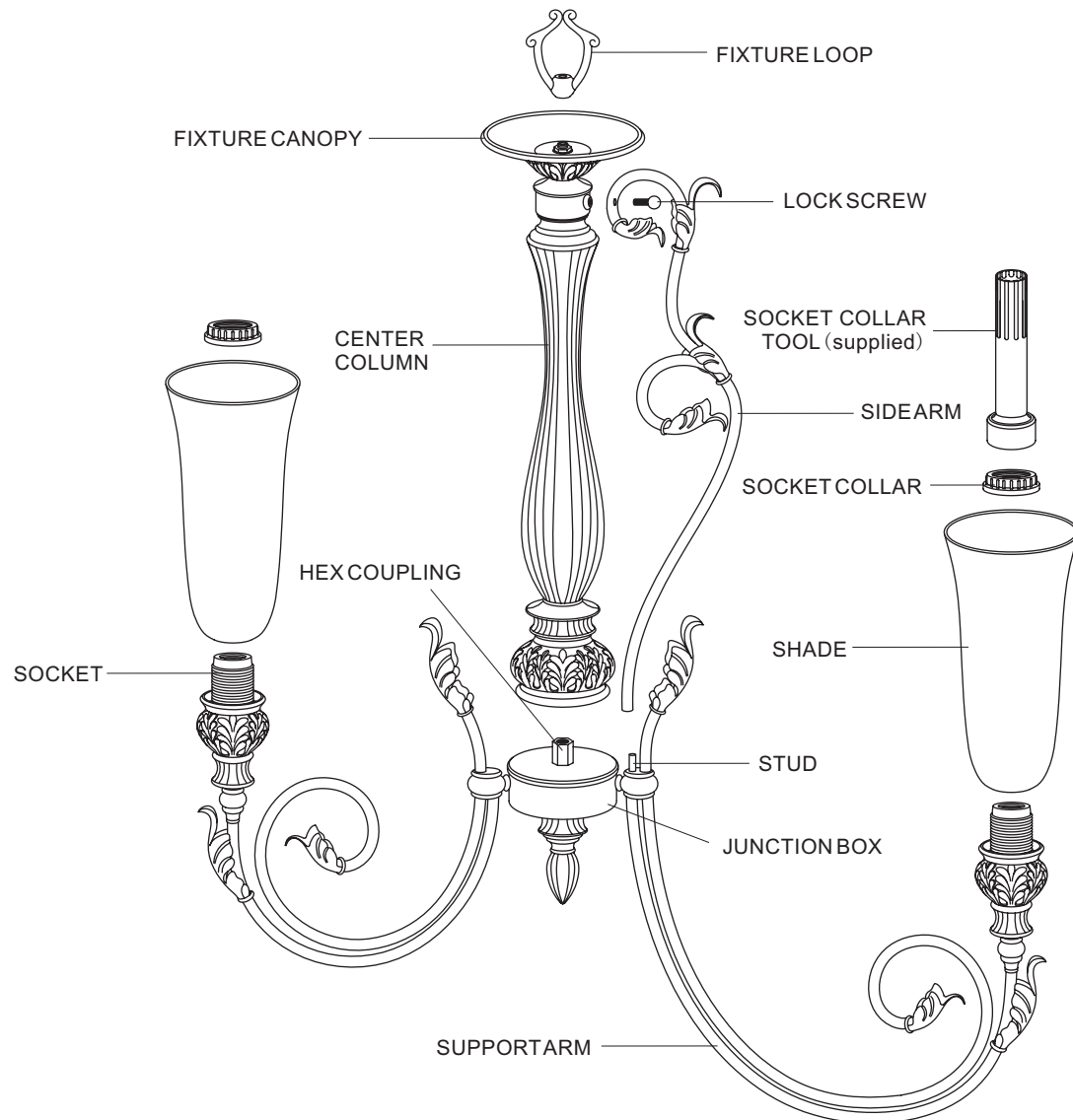

1. Before beginning fixture assembly, carefully unpack all of the parts referring to the illustration for parts identification.
2. Turn the power to installation point OFF at the circuit breaker.
3. Thread the bottom of the CENTER COLUMN onto the HEX COUPLING, located on the top center of the JUNCTION BOX. Hand tighten until snug. Please make sure the mounting holes on the side of the CENTER COLUMN line up the STUDS on the SUPPORT ARMS. Proceed to thread the FIXTURE LOOP onto the nipple on the top center of the FIXTURE CANOPY. Hand tighten until snug.
4. Locate the end of the SIDE ARM over the STUD on the SUPPORT ARM and match the hole on the SIDE ARM with the mounting hole on the side of the CENTER COLUMN. Thread the LOCK SCREW into the mounting hole and hand tighten until snug to secure the SIDE ARM.
- 5. STOP HERE! YOU MUST NOW REFER TO PAGE 2 FOR SPECIFIC CEILING MOUNT INSTALLATION INSTRUCTIONS AND PAGE 3 FOR SAFETY CABLE INSTALLATION INSTRUCTIONS.**
6. Position the SHADE over the SOCKET as shown. Use the SOCKET COLLAR TOOL (supplied), thread the SOCKET COLLAR onto the SOCKET and hand tighten until snug to secure the SHADE.
7. Install the correct bulbs referring to the fixture marking and/or labels for maximum wattage.
8. Restore power to the installation point ON. Retain this sheet for future reference.

**CEILING INSTALLATION INSTRUCTIONS
FOR FIXTURES WEIGHING OVER 45 LBS.**

NOTE: DUE TO THE HANGING WEIGHT OF THIS FIXTURE, QUOIZEL HIGHLY RECOMMENDS YOU CONSULT A LICENSED ELECTRICIAN OR QUALIFIED CONTRACTOR FOR THIS INSTALLATION. QUOIZEL RECOMMENDS (2) PEOPLE FOR THIS INSTALLATION

1. The weight of this fixture will require a means of support **INDEPENDENT** of the **OUTLET BOX**. This fixture must be supported by a 3/8-18 NPSM PIPE (supplied). Assemble the 3/8-18 NPSM PIPE to the HEX COUPLING until it is visible in the side hole opening. (Note that the PIPE has a cotter pin hole on one end, do not thread that end into the HEX COUPLING). Tighten the **SET SCREW** which will lock the pipe in place.

Note: the opposite end of the PIPE must be attached to a structural or bridging member of sufficient strength to support the fixture weight. **NOTE: IT IS RECOMMENDED THAT THE STRUCTURAL OR BRIDGING MEMBER SUPPORT 4 TIMES THE ACTUAL WEIGHT OF THE FIXTURE.**

A 5/8" diameter clearance hole must be drilled on the top inside center of the **OUTLET BOX AND THROUGH THE STRUCTURAL SUPPORT MEMBER**. Slip the PIPE up through the clearance hole in the outlet box and the structural member. Install the **LARGE FLAT WASHER, LOCK WASHER AND LARGE HEX NUT** onto the top side of the PIPE and hand tighten until the coupling touches the top inside of the outlet box. Now install the cotter pin.

2. With your fixture still not mounted yet, proceed to unravel the **FIXTURE WIRES, GROUND WIRE** and the **SAFETY CABLE**.
Locate the **FIXTURE CHAIN** and attach one end of it to the **FIXTURE LOOP** at the top of the **FIXTURE** with a **QUICK-LINK CONNECTOR**. Next decide the length of chain needed for your application. You will be required to remove excess links with bolt cutters.
Proceed to pass the **FIXTURE WIRES, GROUND WIRES** and **SAFETY CABLE** through alternating links on the chain. Proceed to pass the wires through the following mounting components in this order and how it is shown in the illustration on the left:
1) **CANOPY LOCK RING**; 2) **CEILING CANOPY**; 3) **CANOPY CHAIN LOOP**; 4) **LOCK WASHER B** and **LOCK NUT B**;
5) **NIPPLE**; 6) **LOCK NUT A** and **LOCK WASHER A**. Thread **LOCK NUTS A** and **B** approx. 1/2" onto each end of the **NIPPLE**, also slip on **LOCK WASHERS A** and **B**.

3. Position the fixture under the **OUTLET BOX** and pass the fixture wires through the bottom center of the **COUPLING**.
Pull wires through the wire way hole on one side of the **COUPLING**. **STOP HERE! For SAFETY CABLE ROUTING, go to page 3 and choose either OPTION A or OPTION B. If you choose OPTION B, the cable must exit the HEX COUPLING from the opposite side hole of the wiring. Once that is determined and applied, return back to the steps below.**

Assemble the threaded **NIPPLE** into the bottom of the **HEX COUPLING** until it is visible in the side hole opening. Thread **LOCK NUT A** and **LOCK WASHER A** up the **NIPPLE** until they are against the bottom of the **HEX COUPLING** and tighten with pliers or a wrench. **NOTE: DO NOT THREAD NIPPLE BEYOND SIDE HOLE OPENING, DAMAGE TO WIRING AND POSSIBLE ELECTRICAL SHOCK COULD OCCUR!**

4. Next thread the **CANOPY CHAIN LOOP** into the bottom of the **NIPPLE**. Tighten down **HEX NUT B** and **LOCK WASHER B** against it with pliers or a wrench.
Raise the fixture and attach the **FIXTURE CHAIN** to the **CANOPY CHAIN LOOP** with a **QUICK-LINK CONNECTOR**. Pull up all the slack in the wire and the safety cable. You can now trim the wires down to no less than 6" and begin splicing them together.

NOTE: DO NOT CUT THE SAFETY CABLE AT THIS TIME!

Using wire connectors (not provided) connect the **HOUSE GROUND WIRE** to the **FIXTURE GROUND WIRE**; connect the **HOUSE WHITE WIRE** to the **FIXTURE SUPPLY WIRE** (white or ribbed side); connect the **HOUSE BLACK** (or red) **WIRE** to the **FIXTURE SUPPLY WIRE** (black or smooth side). Wrap each connection with approved electrical tape.

5. **STOP HERE!** Before securing the **CEILING CANOPY** to the ceiling, refer to **Page 3** for the **SAFETY CABLE / TUCK WASHER INSTALLATION STEPS**. Once that assembly is completed and the cable is secured, you can refer back to **Step #6** below to complete your fixture installation.

6. Push the **CEILING CANOPY** up over the **OUTLET BOX**. Be sure that all the wires are carefully tucked into the **OUTLET BOX** cavity. Secure the **CEILING CANOPY** against the ceiling by threading the **CANOPY LOCK RING** onto the **CANOPY LOOP**. Tighten until snug.

7. Refer back to **Page 1**, **Step 6** and finish installation.

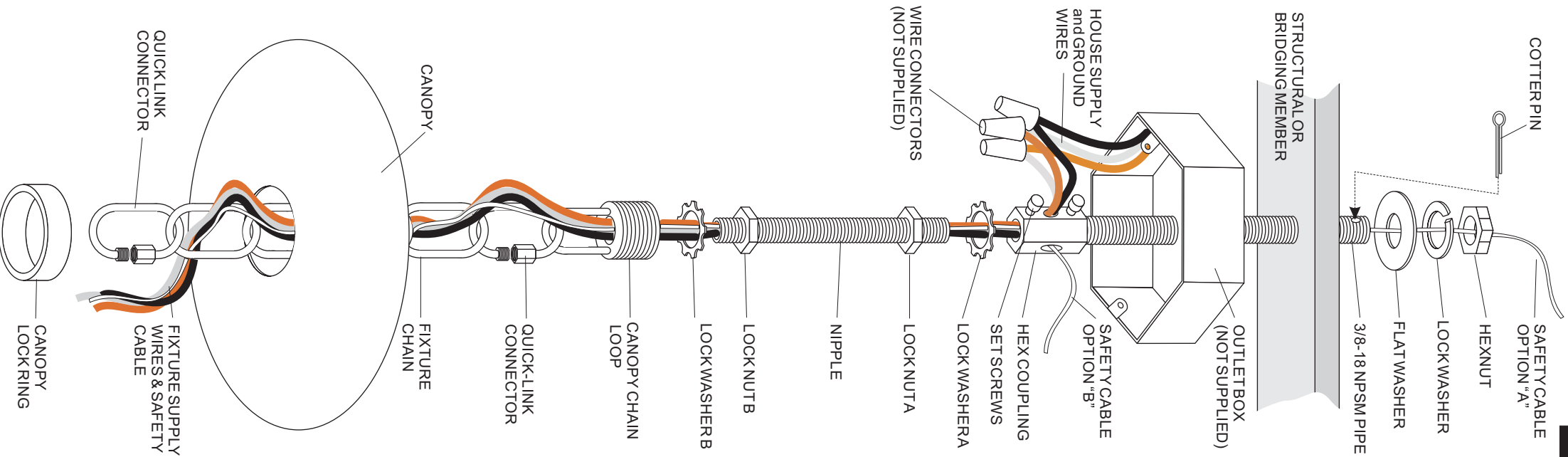

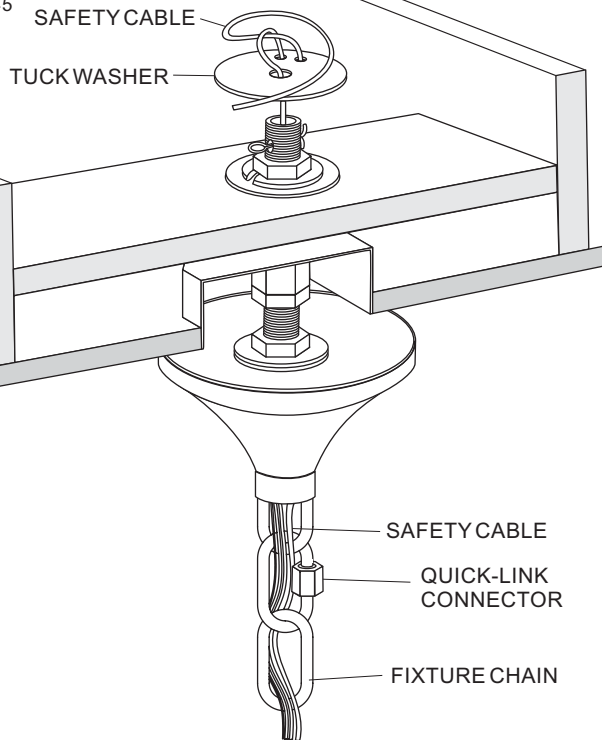
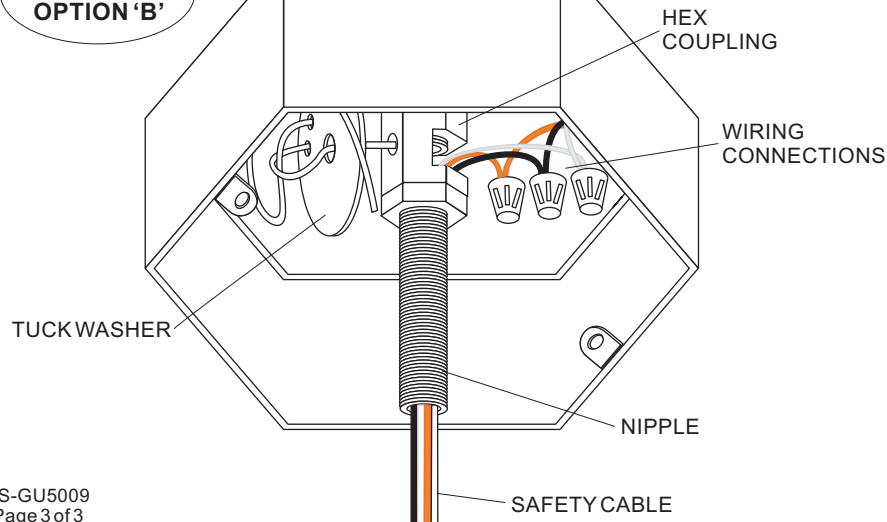

FIGURE #1
OPTION 'A'

FIGURE #2
OPTION 'B'



SAFETY CABLE INSTALLATION INSTRUCTIONS

THIS SAFETY CABLE IS REQUIRED ON ALL SINGLE CHAIN SUSPENDED CEILING FIXTURES WEIGHING OVER 45 POUNDS. IMPROPER INSTALLATION OF THIS SAFETY CABLE COULD RESULT IN FIXTURE FALLING OR SERIOUS INJURY. IF IN DOUBT ABOUT INSTALLATION, YOU MAY NEED TO CONSULT A LICENSED ELECTRICIAN OR QUALIFIED CONTRACTOR.

OPTION 'A' (see FIGURE #1)

Work the SAFETY CABLE END through the FIXTURE CHAIN, alternating every other link. Proceed to pass the SAFETY CABLE END through the NIPPLE, COUPLING and 3/8-18 PIPE. Make up the TUCKWASHER KNOT, referring to Figure #3.

OPTION 'B' (see FIGURE #2)

Pull the SAFETY CABLE through alternating links on the FIXTURE CHAIN and then through the NIPPLE. Pull the SAFETY CABLE out of the **small hole on the side** of the COUPLING. **(NOTE: SAFETY CABLE MUST NOT EXIT COUPLING ON THE WIRE CONNECTION SIDE)** Make up a TUCKWASHER KNOT, referring to Figure #3.

SAFETY CABLE / TUCKWASHER INSTALLATION STEPS - See FIGURE #3

- 1) First, push all of the SAFETY CABLE up through the center hole.
- 2) Next, push the cable down through the 12 o'clock hole, leaving about 1/2" of slack.
- 3) Finally, push the cable up through the 1 o'clock hole and tuck it under the cable between the center hole and the 12 o'clock holes.
- 4) For OPTION 'A': Pull all of excess cable through all of the holes until the TUCK WASHER is very close to the opening at the end of the 3/8-18 NIPPLE. Remove as much slack as possible out of the TUCK WASHER. About 1/2" of slack between TUCK WASHER and the hole is acceptable. (See FIGURE #1)
- 5) For OPTION 'B': Pull all of the excess cable through all of the holes in the TUCK WASHER until the TUCK WASHER is very close to the COUPLING. Remove as much slack as possible. About 1" or less is acceptable. (See FIGURE #2)
- 6) Coil and stow the excess cable near the TUCK WASHER. For excessive cable, the cable can be cut down to a minimum of 12" from the washer. At the COUPLING keep the electrical wiring away from the TUCK WASHER and SAFETY CABLE.

NOTE: THE SLACK IN THE SAFETY CABLE NEEDS TO BE LESS THAN THE SLACK IN THE SUPPLY WIRING.

FIGURE #3
TUCKWASHER

