



Incandescent

Cranbrook  
Motion Sensor  
Energy Star

Outdoor

Type \_\_\_\_\_  
-71  
P5661

Catalog No.	Finish Gilded Iron	Lamping	Dimensions (Inches)			
			A	B	C	D
P5661	-71	1 (m) 60w	6-1/2	12-3/4	8	2-3/4

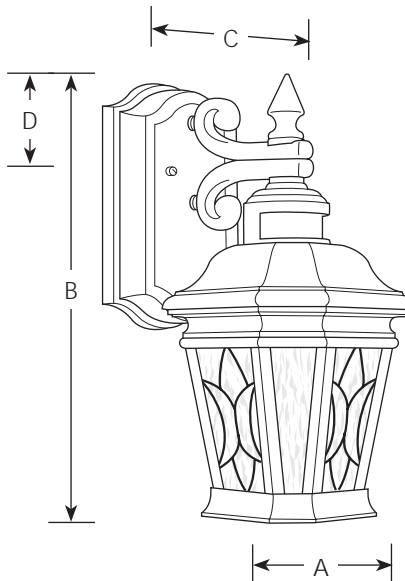

**Specifications:**

General

- Tiffany style water seeded glass panels
- Painted finish
- Socket cover matches fixture finish
- Die cast aluminum construction
- Energy star certified
- Matching post top, chain hung, and wall mounted units without motion sensors

Electrical

- Ceramic medium based socket
- Motion sensor can be set to leave unit on for 5 to 15 minutes after motion ceases
- Integrated photocell included to turn off unit during the daytime
- Pre-wired

Mounting

- Wall mounted outdoor
- Covers standard 4" recessed hexagonal outlet box
- Mounting strap for outlet box included

Labeling

- UL-CUL "Wet Location" listed



Progress Lighting  
701 Millennium Blvd.  
Greenville, South Carolina  
29607

www.progresslighting.com