

Type _____

-101

P4556

P4557

P4558

Catalog No.	Finish	Lamping	Dimensions (Inches)		
	Classic		A	B	C
P4556	Silver -101	3 (c) 60w G16-1/2	26	24-1/4	99
P4557	-101	5 (c) 60w G16-1/2	29-1/2	30-1/4	106
P4558	-101	9 (c) 60w G16-1/2	42	41-1/8	164

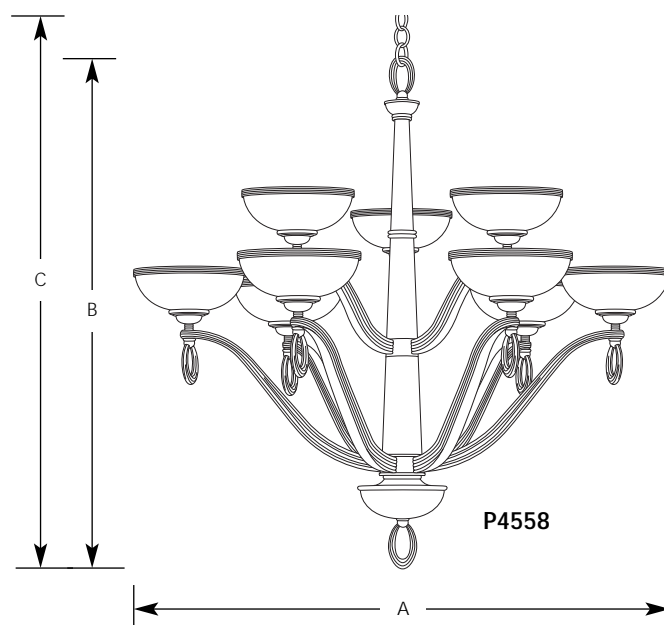
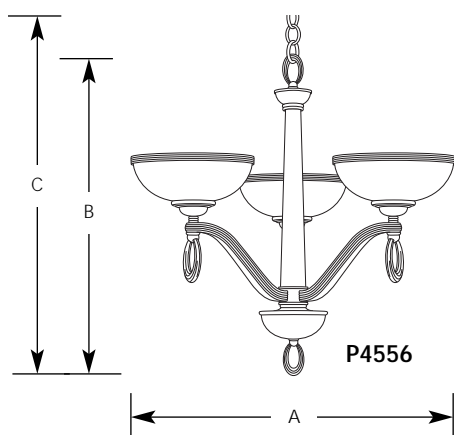

Specifications:

General

- Etched white opal shades with ribbed trim rings
- Uplight style chandeliers
- P4558 is a two tier (6/3) unit
- Brown leather wrapped center columns
- Layered affect curved arms with bottom rings
- Plated classic silver finish
- 10 feet of 9 gauge chain on P4558, 6 feet of 9 gauge chain on P4556 & P4557
- Steel Construction
- Companion hall and foyer, pendant, close to ceiling, and bath and vanity units

Mounting

- Ceiling chain mounted
- Canopy covers a standard 4" hexagonal outlet box
- Mounting strap for outlet box included
- Threaded socket ring secures glass

Electrical

- Phenolic candelabra based sockets, G16-1/2 lamps recommended
- 15 feet of wire supplied
- Pre-wired

Labeling

- UL-CUL listed

Progress Lighting
 Post Office Box 5704
 Spartanburg, South Carolina
 29304-5704