

Type _____
 -31
 P5205

Catalog No.	Finish Black	Lamping	Dimensions (Inches)	
			A	B
P5205	-31	1 (m) 60w	5	7-1/4

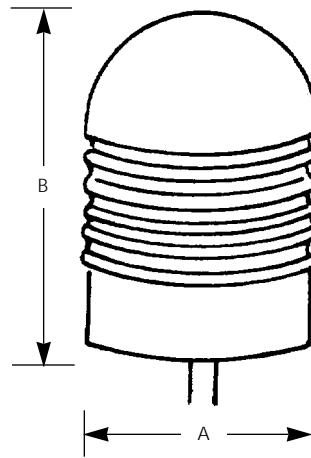

Specifications:

General

- Etched one piece glass with black painted top
- Black finish
- Aluminum construction

Electrical

- Medium based porcelain socket.
- Pre-wired

Labeling

- UL-CUL wet location listed

Mounting

- Mounts on landscape post (P8562-31), stake (P5233-31), or approved weatherproof box (order separately)
- 1/2" NPS thread