

Type _____
-09
P4265

Catalog No.	Finish Brushed Nickel	Lamping	Dimensions (Inches)		
			A	B	C
P4265	-09	18 (c) 60w	34-1/2	21	180

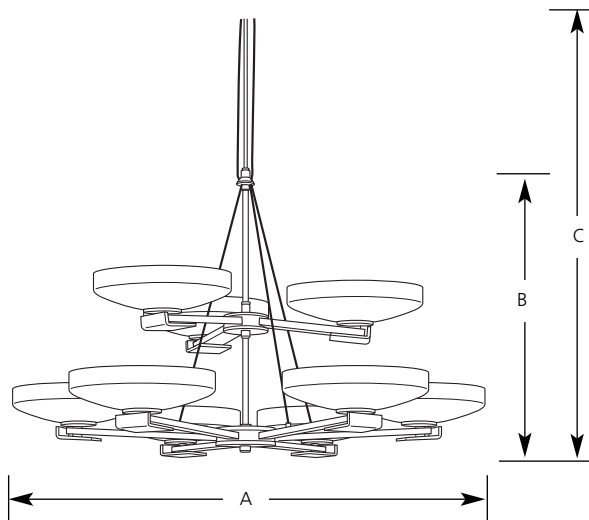

Specifications:

General

- Scroll arms and back plate with decorative leaves
- Optional shades available (see accessories)
- Hand painted finish
- Companion chandelier, hall and foyer, close to ceiling, and table lamp units

Mounting

- Wall mount
- Covers outlet box
- Wall plate covers a standard 4" hexagonal outlet box

Mounting hardware is included

Electrical

- Pre-wired
- Phenolic candelabra base sockets

Labeling

- UL-CUL listed