

Type _____
 -09
 P2982

Catalog No.	Finish	Lamping	Dimensions (Inches)			
	Brushed Nickel		A	B	C	D
P2982	-09	1 (m) 100w	7-3/8	14-1/8	9	10-1/8

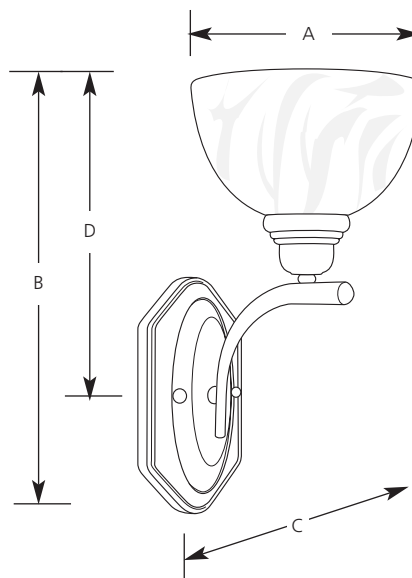

Specifications:

General

- White alabaster glass
- Can be mounted in "up" or "down" position
- Steel construction
- Companion fixtures: Chandeliers, Close to ceiling, and pendant

Electrical

- Pre-wired
- Threaded socket ring secures glass
- Medium based ceramic socket

Labeling

- UL-CUL listed

Mounting

- Wall mount
- Covers outlet box
- Canopy is 4-1/2" wide by 8" high
- Mounting strap for outlet box included