

Type _____
-87
P2962

Catalog No.	Finish Field- stone	Lamping	Dimensions (Inches)			
			A	B	C	D
P2962	-87	3 (m) 100w	24	11-1/4	8	6-3/4

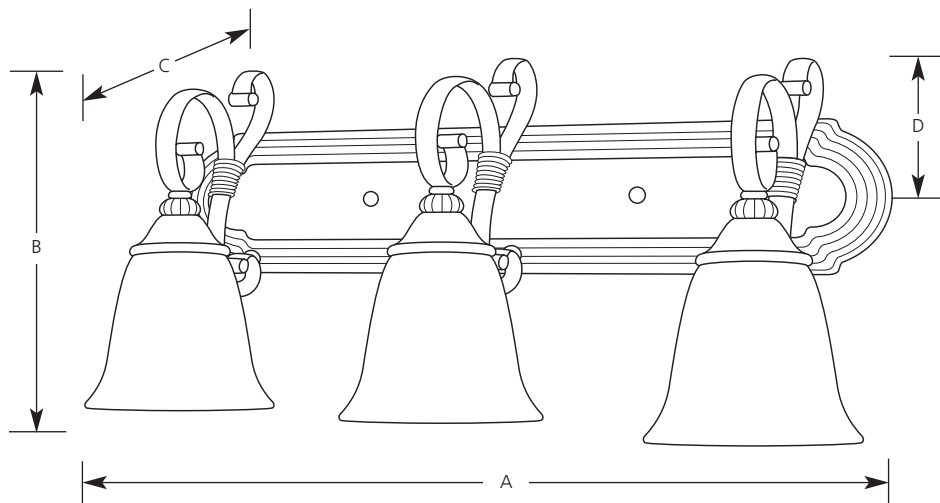

Specifications:

General

- Etched jasmine mist glass shades
- Hand painted finish
- Oval tubing scrolls with wire wrap
- Steel construction
- Companion fixtures: Chandeliers, wall bracket, hall and foyer, pendant, and close to ceiling.

Electrical

- Pre-wired
- Medium based ceramic sockets
- Threaded socket ring secures glass

Labeling

- UL-CUL "Damp Location" listed

Mounting

- Wall mount
- Unit covers a standard 4" octagonal recessed outlet box
- Mounting strap for outlet box included