

Type _____

P745-IC

Catalog No.	Lamping	Dimensions (Inches)			
		A	B	C	D
P745-IC	75w Par30LN/65w BR30	7	7-1/4	8-1/4	19
		Ceiling opening = 7-3/8			
		Maximum Ceiling Thickness = 1-1/4			

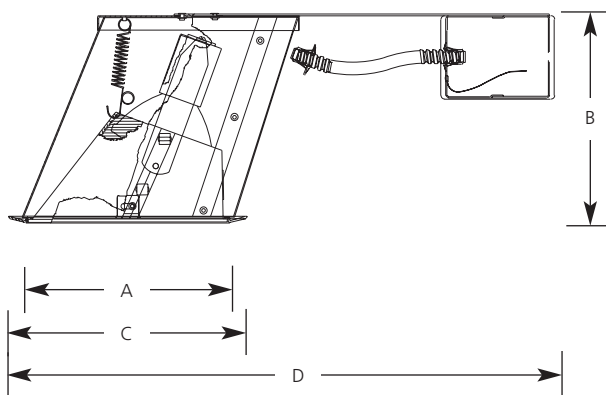

- Trim must be ordered separately.

Specifications:

Wiring

- Universal heavy gauge junction box screw-lock door
- Grounding pigtail
- 1/2" pryouts

Construction

- Galvanized steel construction
- Housing adjusts from 1/2" to 1-1/2" thick ceilings
- Adjustable slide bars lock unit into ceiling
- Porcelain socket with nickel-plated brass screw shell

Labeling

- UL-CUL listed for damp location and feed through wiring (2in, 2out, 12ga.)
- IC rated

Lamp/Trim

- Lamp in vertical position from 9-45 degree sloped ceiling (2/12 to 12/12)
- Lamp is adjustable from below ceiling
- Single spring attachment of trim
- Trim flange is pre-assembled to housing with two sheet metal screws