



Incandescent Trim

6" Shower Light
Non-IC

Recessed

Type _____
-60
P6622

Catalog No.	Finish White	Dimensions (Inches)		
		A	B	C
P6622	-60	7-7/16	1-5/8	8-1/4

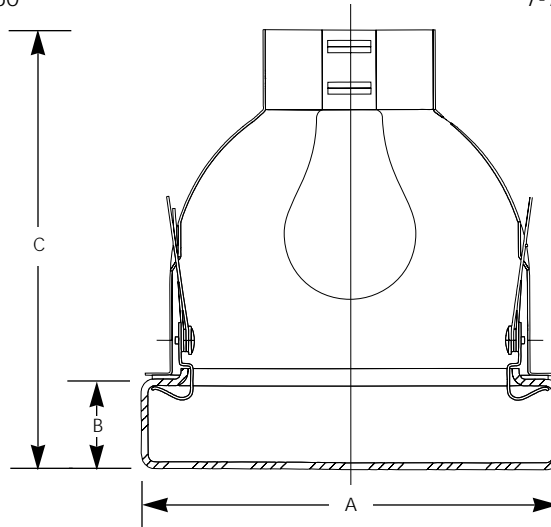

Lamp Wattage

Housing	IC	Non-IC
P11TG	N/A	75A19
P111TG	N/A	75A19

Specifications:

Lens

- Polycarbonate opal diffuser
- Held in place with two torsion springs that lock into the trim
- Supplied with a urethane ceiling gasket

Labels

- UL-CUL wet location listed

Trim

- Full aluminum interior reflector
- Retention clips on housing secure trim snugly against ceiling line
- Designed for use with a 75w A19 lamp maximum
- Socket cup mounts to trim for optimum performance and consistent lamp position

Progress Lighting
Post Office Box 5704
Spartanburg, South Carolina
29304-5704

www.progresslighting.com



Compact Fluorescent

6" Shower Light
Vertical Lamp
Non-IC

Recessed

Type _____
-60
P6622

Catalog No.	Finish White	Dimensions (Inches)		
		A	B	C
P6622	-60	7-1/2	1-5/8	8-1/4

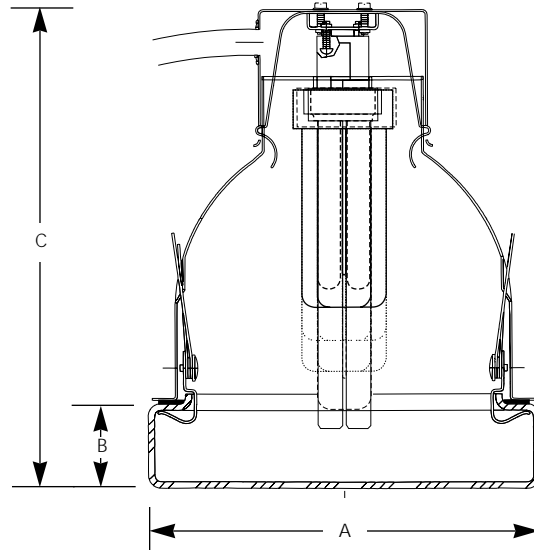

Lamp Wattage

Housing	IC	Non-IC
P13	N/A	1/13w Twin-Tube or Quad (2-pin)
P26	N/A	1/26w Quad (2-pin)
P13-EB	N/A	1/13w Quad (4-pin)
P26-EB	N/A	1/26w Quad (4-pin)
P632-EB	N/A	1/26w or 32w Triple Tube (4-pin)

Specifications:

Trim

- Full aluminum interior reflector
- Retention clips on housing secure trim snugly against ceiling line
- Socket cup mounts to trim for optimum performance and consistent lamp position

Lens

- Acrylic opal diffuser
- Shatter resistant
- Includes gasket

Labels

- UL-CUL wet location listed
- Meets Energy Star requirements when used with P632-EB housing



Progress Lighting
Post Office Box 5704
Spartanburg, South Carolina
29304-5704

www.progresslighting.com

Rev. 5/99

