

**ASSEMBLY
INSTRUCTIONS (RK)**

MODEL NO. **Y32**

Thank you for purchasing this quality product. Be sure to check all packing material carefully for small parts which may have come loose inside the carton during shipment. Separate, identify, and count all parts and metal hardware. Compare with parts list to be sure all parts are present. If any part(s) are missing or damaged, phone, fax, or mail to our Customer Service Department. For efficient and speedy service, please indicate the model number and code letter of part(s) needed.

PARTS

- (A) TOP
- (B) LEGS (4)

ATTENTION: SOME NUMBERED PARTS LISTED ON THE INSTRUCTION SHEET MAY NOT BE IN PARTS BAG AS THEY MAY ALREADY BE ASSEMBLED. CAREFULLY CHECK PARTS AND PACKING MATERIALS PRIOR TO ORDERING REPLACEMENTS.

IMPORTANT NOTE: Follow instructions listed below in the proper sequence as numbered to assure fast, easy and correct assembly.

1. Place parts on a soft cloth. Place Top (A) upside down. Tighten Legs (B) into plates attached to bottom of Top (A).
2. To preserve your lustrous painted finish, wipe with a soft damp cloth. DO NOT use cleaners or abrasives as they may damage the finish.

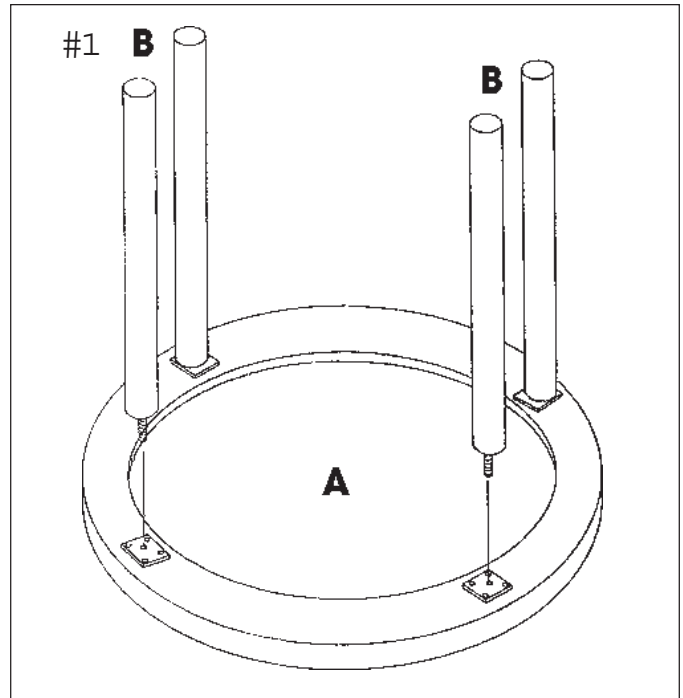

If you have a problem, we want to have the opportunity to make it right!

Should there be any missing or defective part(s),		© 2000 Powell
PLEASE DO NOT RETURN THIS PRODUCT TO THE STORE		Model No.
<i>(Many problems can be resolved without returning this product to the retailer)</i>		Y32
FAX this form to (310) 841-0842		Name _____
or call Customer Service at (800) 622-4456 or (310) 204-2224		Address _____
Have your model number and part code letter handy.		Daytime Phone () _____
Part Letter	Description	Quantity
Part Letter	Description	Quantity
Part Letter	Description	Quantity
		Reason for Replacement _____
		Place of Purchase _____
Powell Service Department • P.O. Box 1408, Culver City, CA 90232-1408		Made in China