

ASSEMBLY

INSTRUCTIONS (JC)

MODEL NO. **Y19**

Made in China

Thank you for purchasing this quality product. Be sure to check all packing material carefully for small parts which may have come loose inside the carton during shipment. Separate, identify, and count all parts and metal hardware. Compare with parts list to be sure all parts are present. If any part(s) are missing or damaged, phone, fax, or mail to our Customer Service Department. For efficient and speedy service, please indicate the model number and code letter of part(s) needed.

PARTS

- (A) ELEPHANT BACK PANEL
- (B) GIRAFFE BACK PANEL
- (C) TIGER BACK PANEL
- (D) ZEBRA BACK PANEL

- (E) FRONT PANELS (4)
- (F) SEATS (4)
- (G) CROSS RAILS (8)

- (H) MACHINE SCREWS (32)
- (I) WOOD SCREWS (16)
- (J) HANGER BOLTS (32)

HARDWARE ILLUSTRATION

Tools required: Screwdriver (not included)



H

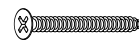

I



J

ATTENTION: SOME NUMBERED PARTS LISTED ON THE INSTRUCTION SHEET MAY NOT BE IN PARTS BAG AS THEY MAY ALREADY BE ASSEMBLED. CAREFULLY CHECK PARTS AND PACKING MATERIALS PRIOR TO ORDERING REPLACEMENTS.

IMPORTANT NOTE: Follow instructions listed below in the proper sequence as numbered to assure fast, easy and correct assembly.

1. **NOTE:** Match Cross Rails (G), Front Panels (E) and Seats (F) with corresponding colors of Elephant, Giraffe, Tiger and Zebra Back Panels (A, B, C, D).
2. Place parts on a soft cloth. Insert Hanger Bolts (J) into Cross Rails (G) with slot for screwdriver facing outward. Align threads of Hanger Bolts (J) with holes on end of Cross Rails (G). Tighten Machine Screws (H) through Elephant, Giraffe, Tiger and Zebra Back Panels (A, B, C, D) into Hanger Bolts (J). Tighten Machine Screws (H) through Front Panels (E) into Hanger Bolts (J). (See ill. #1, #2, #3, #4)
3. Tighten Wood Screws (I) through Rails attached to Elephant, Giraffe, Tiger and Zebra Back Panels (A, B, C, D) and Front Panels (E) into undersides of Seats (F). (See ill. #5, #6, #7, #8)

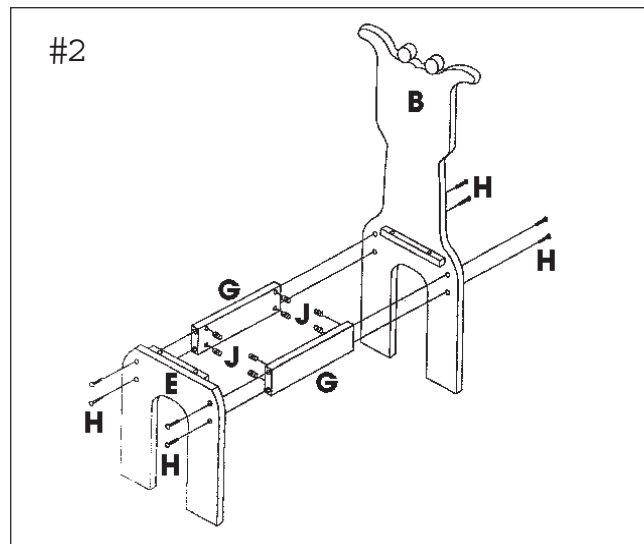
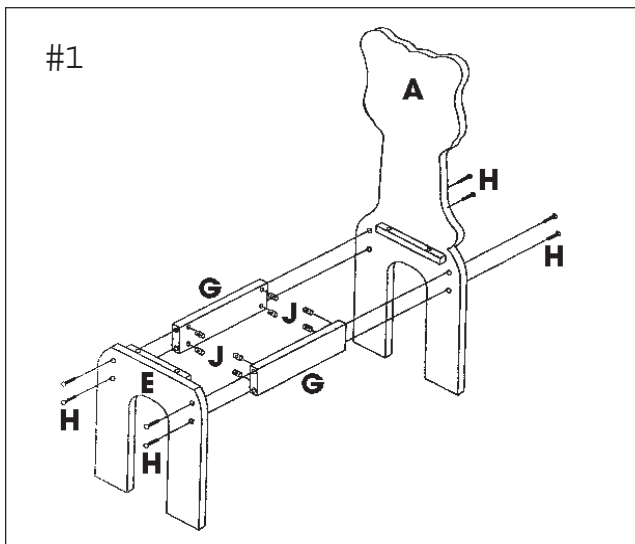

4. To preserve your lustrous painted finish, wipe with a soft damp cloth. DO NOT use cleaners or abrasives as they may damage the finish.

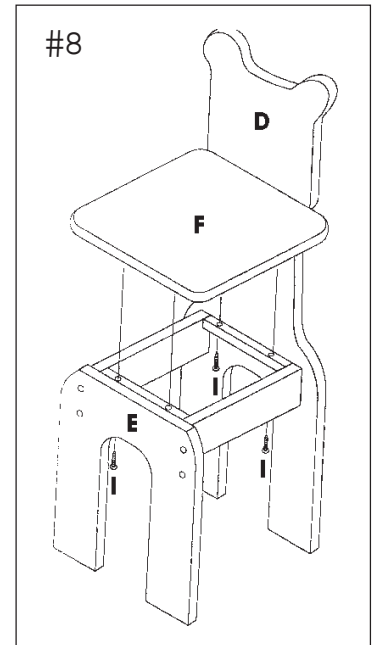
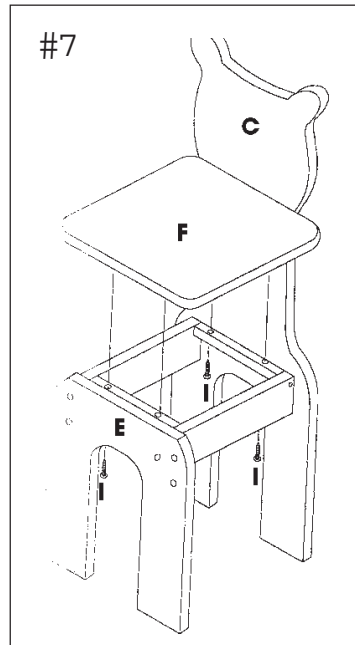
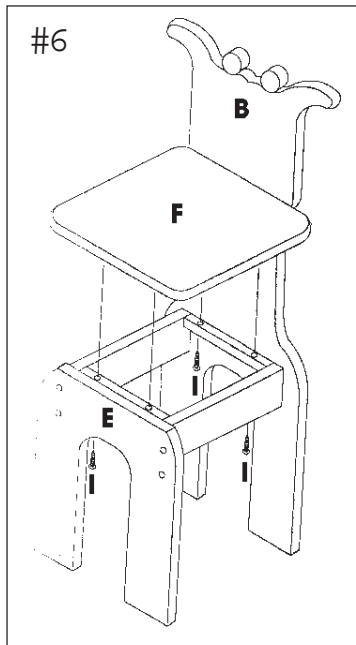
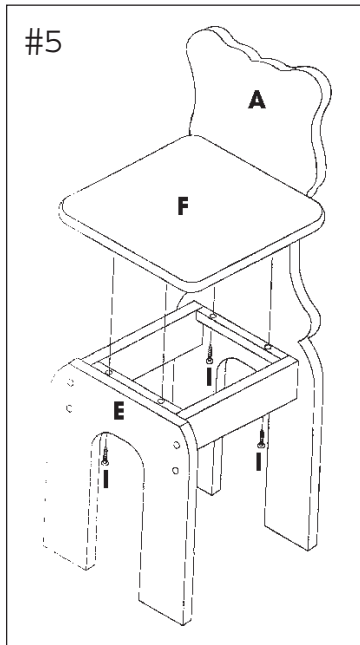
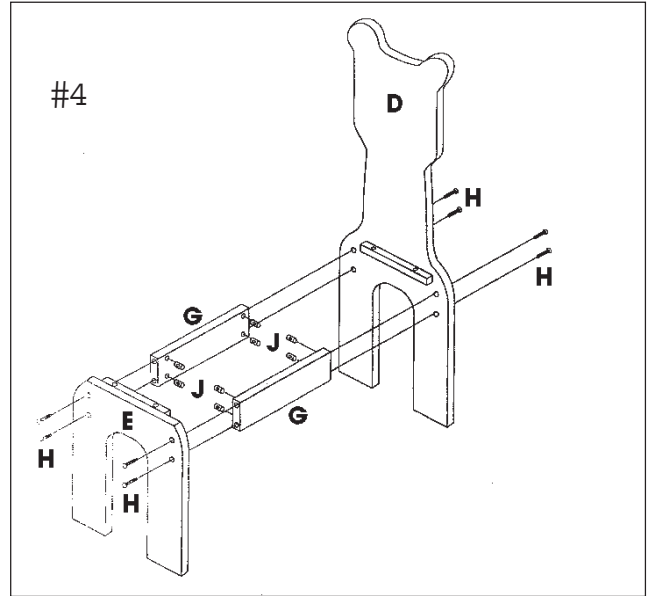
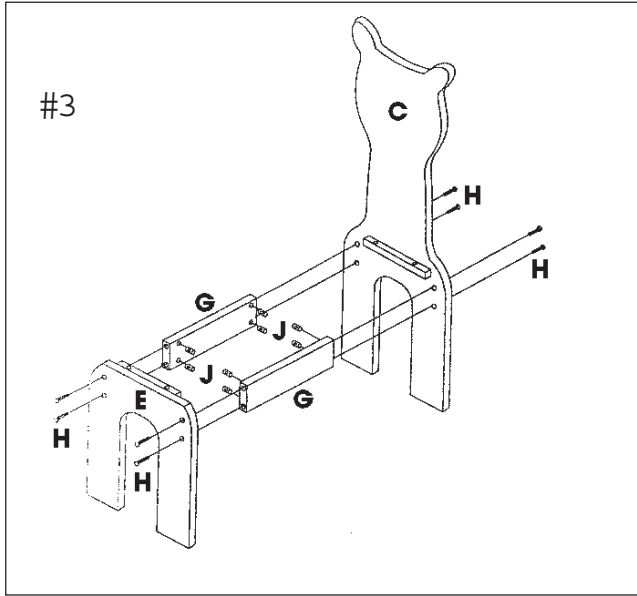

If you have a problem, we want to have the opportunity to make it right!

Should there be any missing or defective part(s),
PLEASE DO NOT RETURN THIS PRODUCT TO THE STORE

(Many problems can be resolved without returning this product to the retailer)

© 2000 Powell

Model No.
Y19

FAX this form to (310) 841-0842

or call Customer Service at (800) 622-4456 or (310) 204-2224
 Have your model number and part code letter handy.

Part Letter	Description	Quantity

Name _____
 Address _____

 Daytime Phone () _____
 Reason for Replacement _____

 Place of Purchase _____