

PARTS

- (A) CABINET
- (B) RACK FRAME
- (C) SMALL SHELF
- (D) LARGE SHELF
- (E) GLASS RACK
- (F) BOTTLE RACKS (2)
- (G) FRONT LEGS (2)
- (H) REAR LEGS (2)
- (I) LONG WOOD SCREWS (32)
- (J) SHORT WOOD SCREWS (12)

HARDWARE ILLUSTRATION

TOOLS REQUIRED: SCREWDRIVER (NOT INCLUDED)



Thank you for purchasing this quality product. Be sure to check all packing material carefully for small parts which may have come loose inside the carton during shipment. Separate, identify, and count all parts and metal hardware. Compare with parts list to be sure all parts are present. If any part(s) are missing or damaged, phone, fax, or mail to our Customer Service Department. For efficient and speedy service, please indicate the model number and code letter of part(s) needed.

ATTENTION: SOME NUMBERED PARTS LISTED ON THE INSTRUCTION SHEET MAY NOT BE IN PARTS BAG AS THEY MAY ALREADY BE ASSEMBLED. CAREFULLY CHECK PARTS AND PACKING MATERIALS PRIOR TO ORDERING REPLACEMENTS.

IMPORTANT NOTE: Follow instructions listed below in the proper sequence as numbered to assure fast, easy and correct assembly.

1. Place parts on a soft cloth. Stand Rack Frame (B) upright and open side panels. (See ill. #1)
2. Insert Short Wood Screws (J) through Glass Rack (E) and tighten into underside of Small Shelf (C). Note: Prongs for holding glasses must point toward front of Small Shelf (C). (See ill. #2)
3. Insert Short Wood Screws (J) through Bottle Racks (F) and tighten into underside of Large Shelf (D). (See ill. #3)
4. Rest Small Shelf (C) onto upper flanges of Rack Frame (B) and Large Shelf (D) onto lower flanges with Bottle Racks (F) and Glass Rack (E) facing downward. Insert Long Wood Screws (I) through flanges of Rack Frame (B) and tighten into Small Shelf (C) and Large Shelf (D). (See ill. #4)
5. Place Cabinet (A) upside down on a soft cloth. Align Rear Legs (H) with rear corners of Cabinet (A) and Front Legs (G) with front corners of Cabinet (A). Insert Long Wood Screws (I) through tops of Legs (G,H) and tighten into corners of Cabinet (A). (See ill. #5)
6. Stand Cabinet (A) upright. Place assembled Rack Frame (B) onto top of Cabinet (A). Insert Long Wood Screws (I) through base of Rack Frame (B) and tighten into top of Cabinet (A). (See ill. #6)
7. Your furniture has been handcrafted and skillfully finished by fine craftsmen. To preserve the rich finish, WIPE ONLY WITH A SOFT, DRY CLOTH. DO NOT use any kind of a brass polish, polishing compound, or other cleaning materials or solutions as they may destroy this protective coating.

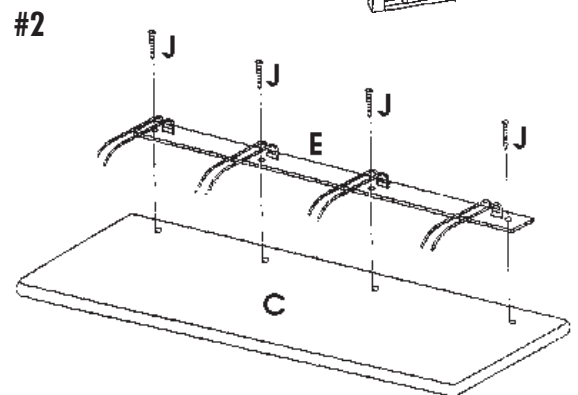
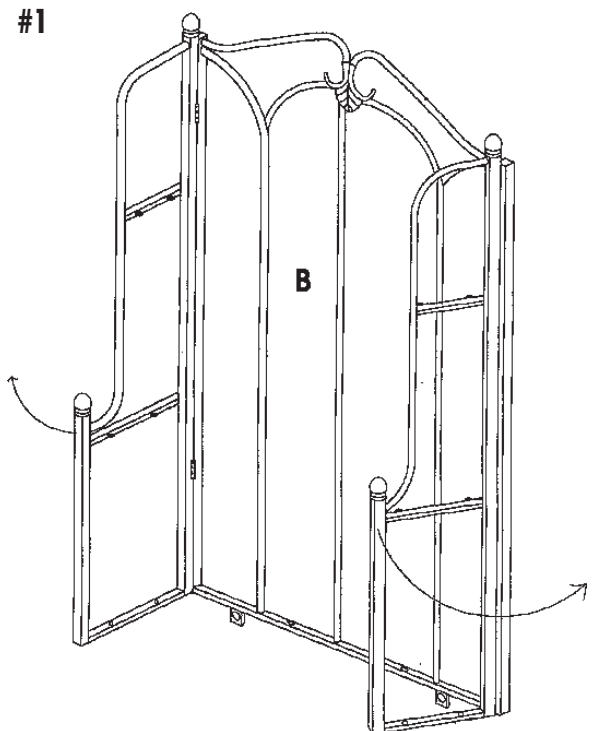

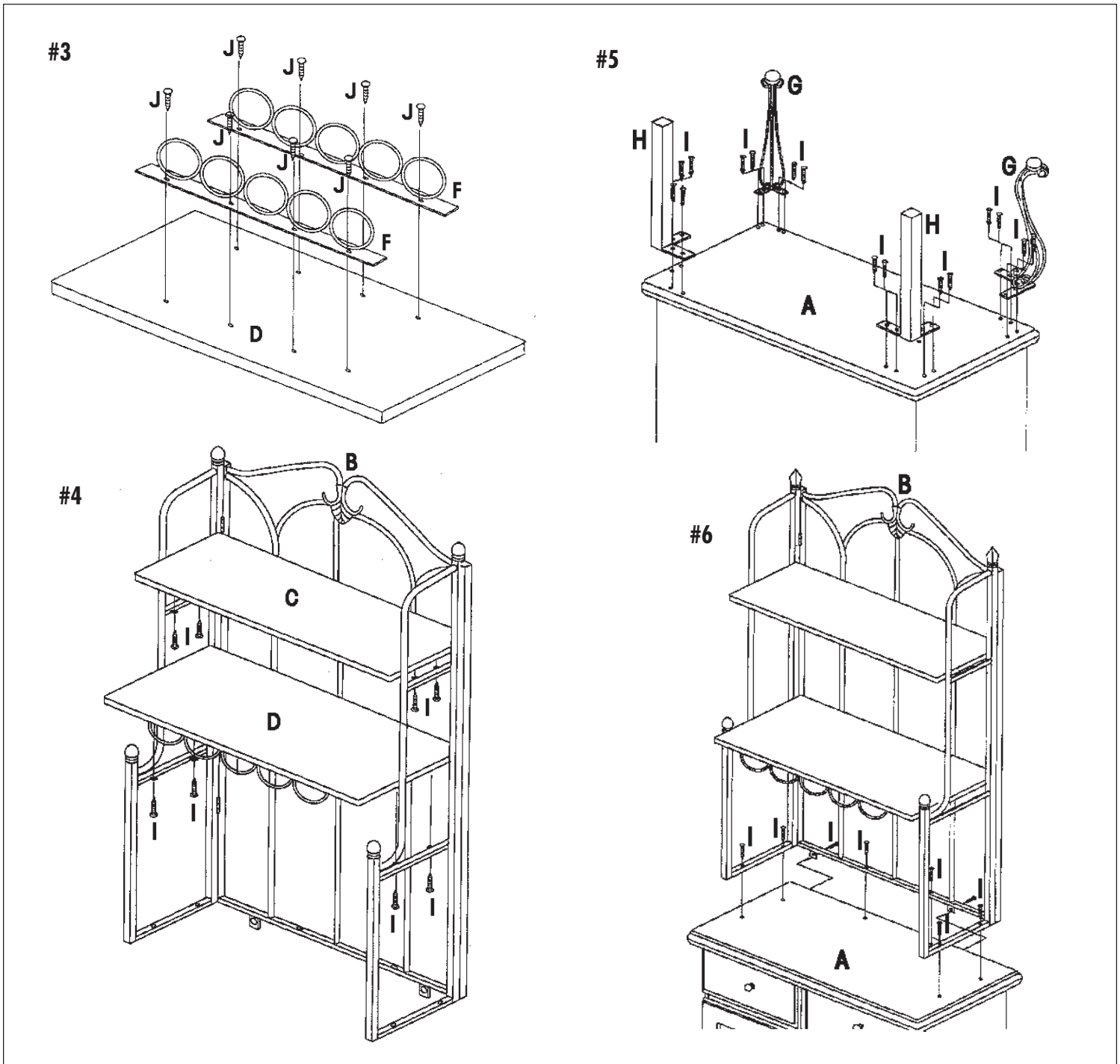

IF YOU HAVE A PROBLEM, WE WANT TO HAVE THE OPPORTUNITY TO MAKE IT RIGHT!

Should there be any missing or defective part(s),
FAX this form to (310) 841-0842
 or call and ask for Customer Service at (800) 622-4456 or (310)
 204-2224. Have your model number and part code letter handy.

MODEL NO. A60H

© 1998 Powell

Part Letter	Description	Quantity

Name _____
 Address _____

 Daytime Phone () _____
 Reason for Replacement _____

 Place of Purchase _____