

PARTS

- | | |
|--------------------------|-------------------------------|
| (A) LEFT BASE END PANEL | (Q) CAM-BOLTS (22) |
| (B) RIGHT BASE END PANEL | (R) CAM-LOCKS (22) |
| (C) BASE BACK PANEL | (S) COVERS (22) |
| (D) BASE FRONT PANEL | (T) LARGE DOWELS (6) |
| (E) RIGHT CORNER POST | (U) SMALL DOWELS (18) |
| (F) LEFT CORNER POST | (V) WASHERS (4) |
| (G) BOTTOM | (W) HANGER BOLTS (10) |
| (H) FEET (4) | (X) LID STAY |
| (I) LEFT BACK PANEL | (Y) HOOKS (5) |
| (J) RIGHT BACK PANEL | (Z) HINGES (3) |
| (K) TOP BACK PANEL | (Aa) LARGE WOOD SCREWS (9) |
| (L) SMALL LID | (Bb) SMALL WOOD SCREWS (43) |
| (M) LEFT SIDE PANEL | (Cc) LONG MACHINE SCREWS (10) |
| (N) RIGHT SIDE PANEL | (Dd) SHORT MACHINE SCREWS (4) |
| (O) TOP PANEL | (Ee) FOAM PADS (2) |
| (P) LARGE LID | |

Thank you for purchasing this quality product. Be sure to check all packing material carefully for small parts which may have come loose inside the carton during shipment. Separate, identify, and count all parts and metal hardware. Compare with parts list to be sure all parts are present. If any part(s) are missing or damaged, phone, fax, or mail to our Customer Service Department. For efficient and speedy service, please indicate the model number and code letter of part(s) needed.

ATTENTION: SOME NUMBERED PARTS LISTED ON THE INSTRUCTION SHEET MAY NOT BE IN PARTS BAG AS THEY MAY ALREADY BE ASSEMBLED. CAREFULLY CHECK PARTS AND PACKING MATERIALS PRIOR TO ORDERING REPLACEMENTS.

HARDWARE ILLUSTRATION

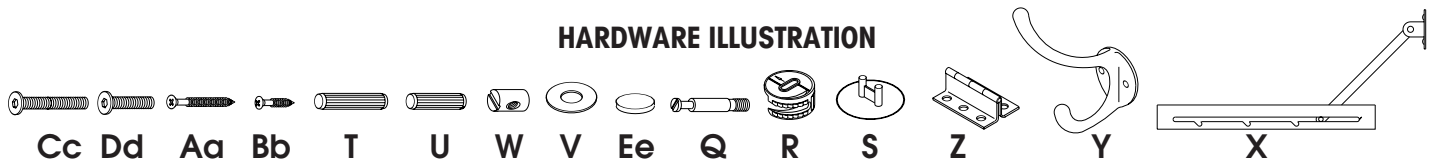

Tools required: Screwdriver and Wrench (not included)

IMPORTANT NOTE: Follow instructions listed below in the proper sequence as numbered to assure fast, easy and correct assembly.

- Note:** Upon opening, thoroughly clean all wood surfaces with furniture polish to remove dust and dirt that may have settled onto finish during shipment.
- Place parts on a soft cloth. Tighten Cam-bolts (Q) into threaded holes in Left and Right Base End Panels (A,B). Insert Cam-bolts (Q) extending from End Panels (A,B) into ends of Back Base Panel (C). Insert Cam-locks (R) into large holes in Back Base Panels (C) with slot for screwdriver facing outward. Rotate Cam-locks (R) clockwise to secure Cam-bolts (Q). Insert Covers (S) into Cam-locks (R). (See ill. #1)
- Tighten Cam-bolts (Q) into threaded holes in Left and Right Corner Post (E,F). Insert Cam-bolts (Q) extending from Left and Right Corner Post (E,F) into ends of Front Base Panel (D) and End Panels (A,B). Insert Cam-locks (R) into large holes in Front Base Panels (D) and End Panels (A,B) with slot for screwdriver facing outward. Rotate Cam-locks (R) clockwise to secure Cam-bolts (Q). Insert Covers (S) into Cam-locks (R). (See ill. #1)

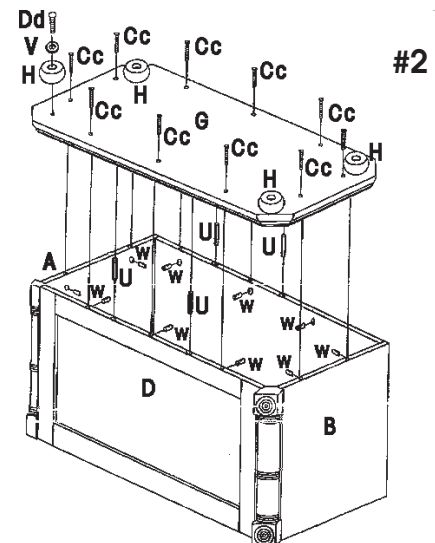
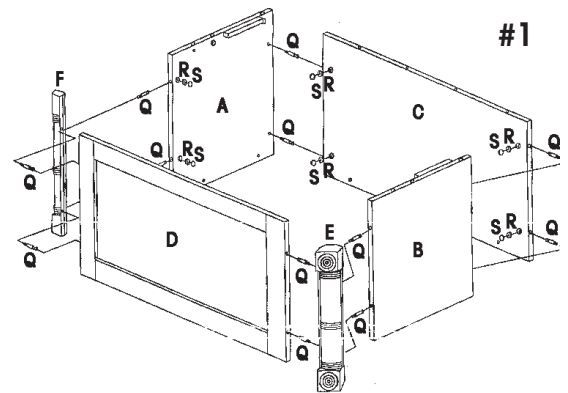

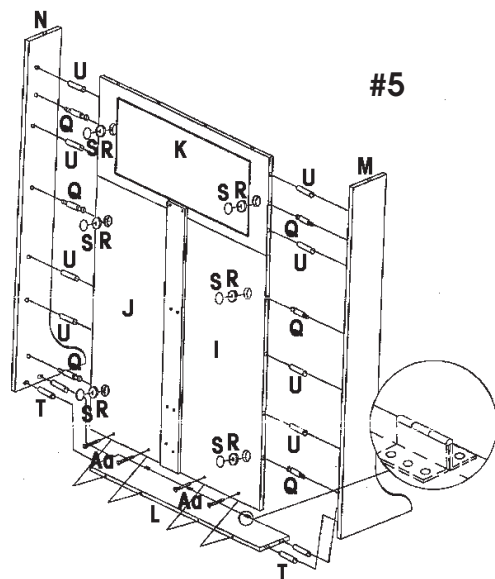
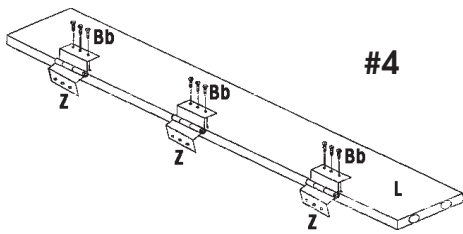
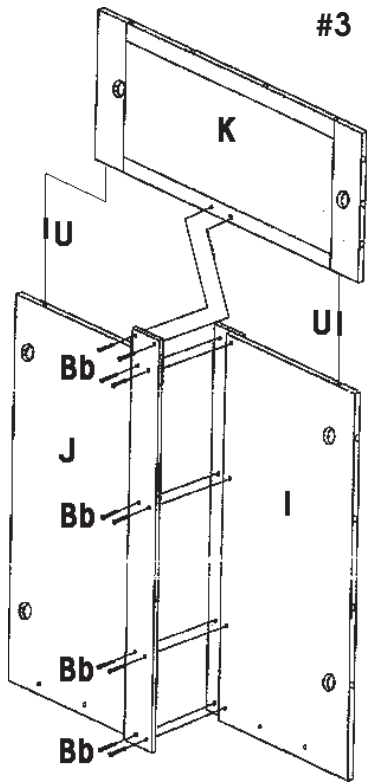

4. Insert Hanger Bolts (W) into interior holes near bottom edge of Back and Front Base Panels (C,D), left and Right Base Panels (A,B) with slot for screwdriver facing outward. Insert Small Dowels (U) into Bottom (G). Tighten Long Machine Screws (Cc) through Bottom (G), edge of Panels (A,B,C,D) into Hanger Bolts (W). Tighten Short Machine Screws (Dd) through Washers (V), Feet (H) into corners of Bottom (G). (See ill. #2)
5. Align Right and Left Back Panels (I,J). NOTE: Large holes for Cam-locks (Q) face outward. Tighten Small Wood Screws (Bb) through center panel attached to Left Back Panel (I) into center panel attached to Right Back Panel (J). Insert Small Dowels (U) into top edge of Left and Right Back Panels (I,J). Insert Small Dowels (U) extending from Left and Right Back Panels (I,J) into Top Back Panel (K). Tighten Small Wood Screws (Bb) through top holes in center panel attached to Right Back Panel (J) into Top Back Panel (K). (See ill. #3)
6. Tighten Small Wood Screws (Bb) through Hinges (Z) into Small Lid (L). (See ill. #4)
7. Tighten Cam-bolts (Q) into threaded holes in Left and Right Side Panels (M,N). Insert Large and Small Dowels (T,U) into Left and Right Side Panels (M,N). Insert Cam-bolts (Q), Large and Small Dowels (T,U) extending from Left and Right Side Panels (M,N) into Left and Right Back Panels (I,J), Top Back Panel (K) and ends of Small Lid (L). Insert Cam-locks (R) into large holes in Left, Right, and Top Back Panels (I,J,K) with slot for screwdriver facing outward. Rotate Cam-locks (R) clockwise to secure Cam-bolts (Q). Insert Covers (S) into Cam-locks (R). Insert Large Wood Screws (Aa) through Left and Right Back Panels (I,J) and tighten into Small Lid (L). (See ill. #5)
8. Insert Large Dowels (T) into holes in top edge of Top Back Panel (K). Tighten Large Wood Screws (Aa) through Top Panel (O) into top edge of Left and Right Side Panels (M,N) and Top Back Panel (K). (See ill. #6)
9. Lay back assembly flat. Tighten Cam-bolts (Q) into threaded holes on bottom edge of Left and Right Side Panels (M,N). Insert Small Dowels (U) into remaining holes on bottom edge of Left and Right Back Panels (I,J). Lay assembled base onto Base Back Panel (C) and insert Cam-bolts (Q) and Small Dowels (U) extending from Back Panels (I,J) into top edge of Base Panels (A,B,C). Insert Cam-locks (R) into large holes in Base Back and End Panels (A,B,C) with slot for screwdriver facing outward. Rotate Cam-locks (R) clockwise to secure Cam-bolts (Q). Insert Covers (S) into Cam-locks (R). Tighten Small Wood Screws (Bb) through Left Base End Panels (A) into Left Side Panels (M). (See ill. #7)

10. Insert Small Wood Screws (Bb) through Hinges (Z) attached to Small Lid (L) and tighten into Large Lid (P). Insert Small Wood Screws (Aa) through Lid Stay (X) and tighten into Right Base End Panel (B) and underside of Large Lid (P). Insert Small Wood Screws (Aa) through Hooks (Y) and tighten into lower front edge of Top Back Panel (K). Place Foam Pads (Ee) on top of Left and Right Corner Posts (E,F). (See ill. #8)

11. Your furniture has been handcrafted and skillfully finished by fine craftsmen. Rich, deep antique finishes have been applied which require very little polish. However, should you desire a shinier finish, simply use any good grade of furniture polish, rubbing the finish lightly as it is being applied. Allow to dry and buff lightly with a soft cloth.

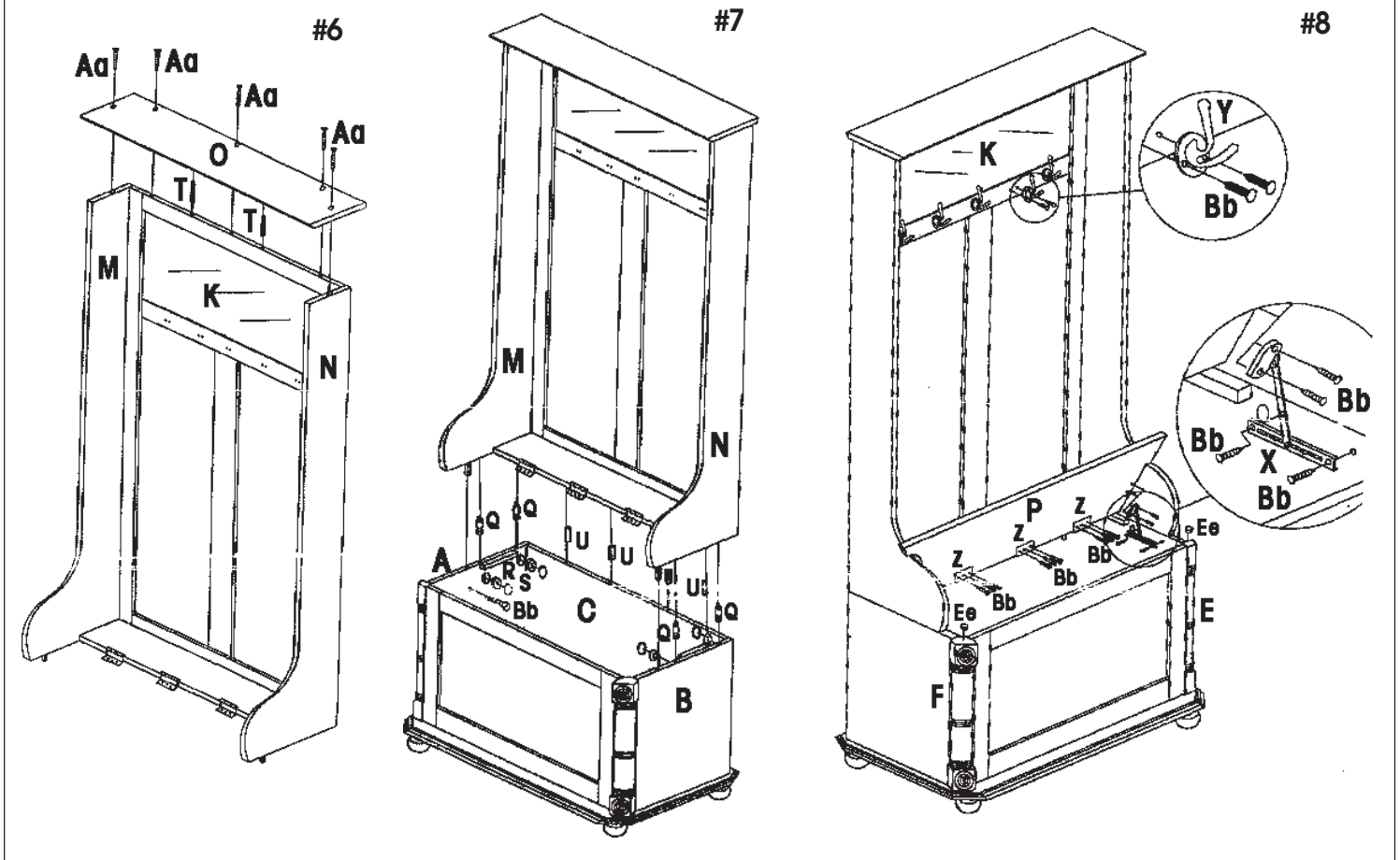

IF YOU HAVE A PROBLEM, WE WANT TO HAVE THE OPPORTUNITY TO MAKE IT RIGHT!

Should there be any missing or defective part(s),

FAX this form to (310) 841-0842

or call Customer Service at (310) 204-2224

Have your model number and part code letter handy.

MODEL NO. 998-299

© 2001 Powell

Part Letter	Description	Quantity

Name _____

Address _____

Daytime Phone () _____

Reason for Replacement _____

Place of Purchase _____