

PARTS

- (A) END PANEL
- (B) LEGS (2)
- (C) END CAPS (2)
- (D) MACHINE SCREWS (4)
- (E) LOCK WASHERS (4)
- (F) METAL WASHERS (4)
- (G) PLASTIC WASHERS (4)
- (H) WRENCH

HARDWARE ILLUSTRATION

Tools required: Wrench

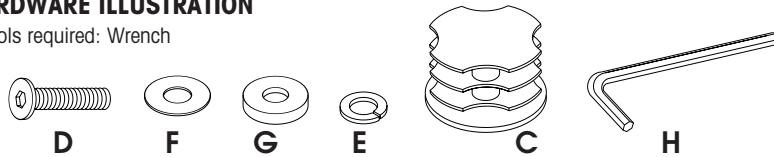

Thank you for purchasing this quality product. Be sure to check all packing material carefully for small parts which may have come loose inside the carton during shipment. Separate, identify, and count all parts and metal hardware. Compare with parts list to be sure all parts are present. If any part(s) are missing or damaged, phone, fax, or mail to our Customer Service Department. For efficient and speedy service, please indicate the model number and code letter of part(s) needed.

ATTENTION: SOME NUMBERED PARTS LISTED ON THE INSTRUCTION SHEET MAY NOT BE IN PARTS BAG AS THEY MAY ALREADY BE ASSEMBLED. CAREFULLY CHECK PARTS AND PACKING MATERIALS PRIOR TO ORDERING REPLACEMENTS.

IMPORTANT NOTE: Follow instructions listed below in the proper sequence as numbered to assure fast, easy and correct assembly.

TO ASSEMBLE AS HEADBOARD:

- Place parts on a soft cloth. Insert tops of Legs (B) into bottom of End Panel (A). Insert End Caps (C) into end of Legs (B). Insert Machine Screws (D) through Lock Washers (E), Metal Washers (F), bed frame (not included), Plastic Washers (G), and tighten into Legs (B). Insert End Caps (C) into end of End Panel (A). (See Ill. #1 & #2)

TO ASSEMBLE AS FOOTBOARD:

- Insert Machine Screws (D) through Lock Washers (E), Metal Washers (F), bed frame (not included), Plastic Washers (G), and tighten into End Panel (A). Insert End Caps (C) into end of End Panel (A). (See ill. #2)
- To preserve your lustrous painted finish, wipe with a soft damp cloth. DO NOT use cleaners or abrasives as they may damage the finish.

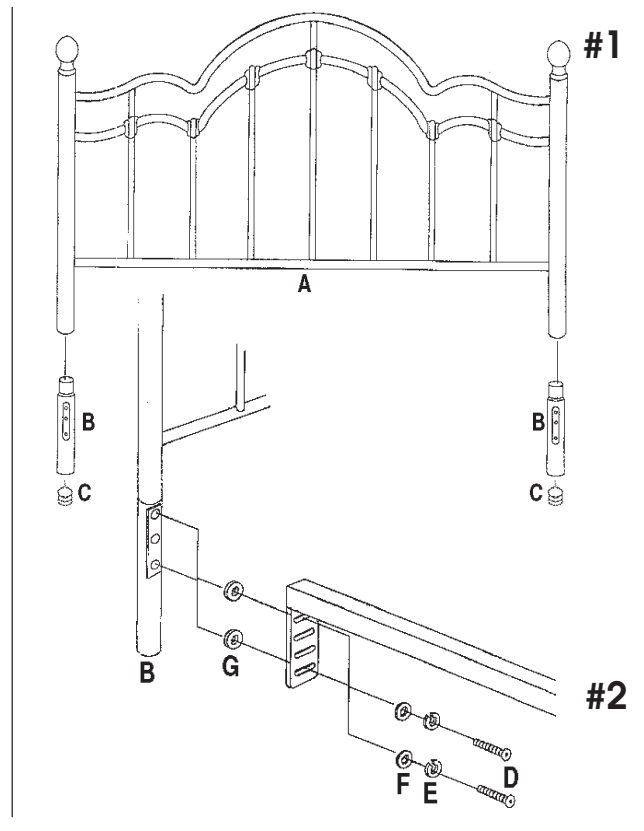

IF YOU HAVE A PROBLEM, WE WANT TO HAVE THE OPPORTUNITY TO MAKE IT RIGHT!

Should there be any missing or defective part(s),

FAX this form to (310) 841-0842

or call Customer Service at (800) 622-4456 or (310) 204-2224

Have your model number and part code letter handy.

MODEL NO. 979-072 FULL

© 2001 Powell

979-073 QUEEN

979-074 KING

Part Letter	Description	Quantity

Name _____

Address _____

Daytime Phone () _____

Reason for Replacement _____

Place of Purchase _____