

Thank you for purchasing this quality product. Be sure to check all packing material carefully for small parts which may have come loose inside the carton during shipment. Separate, identify, and count all parts and metal hardware. Compare with parts list and hardware illustrations to be sure all parts are present. If any part(s) are missing or damaged, phone, fax, or mail to our Customer Service Department. For efficient and speedy service, please indicate the model number and code letter of part(s) needed.

ATTENTION: SOME LETTERED PARTS LISTED ON THE INSTRUCTION SHEET MAY NOT BE IN PARTS BAG AS THEY MAY ALREADY BE ASSEMBLED. CAREFULLY CHECK PARTS AND PACKING MATERIALS PRIOR TO ORDERING REPLACEMENTS. PRODUCT MUST BE COMPLETED BEFORE FULLY TIGHTENING SCREWS

Tools Required for assembly: Allen Wrench (included).

This bed is designed to use only a mattress which is 74" - 75" long and 37-1/2" - 38-1/2" wide. ensure thickness of mattress does not exceed 8" and mattress is at least 5" below upper edge of guardrail.

Replacement parts, including additional guardrails, may be obtained from Powell Company.

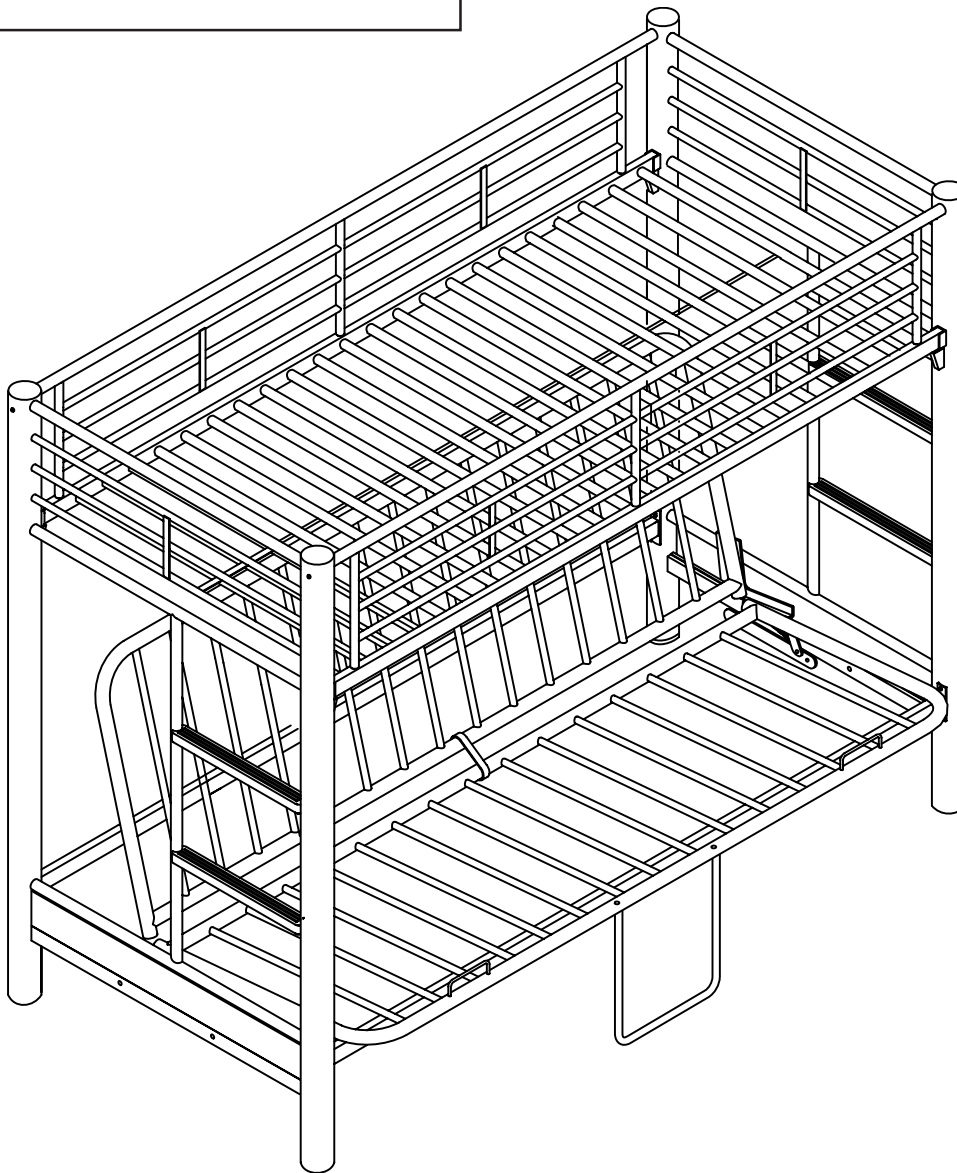

PARTS

- (A) LEFT PANEL
- (B) RIGHT PANEL
- (C) GUARDRAILS (2)
- (D) BED FRAME
- (E) LONG CROSS BRACE (2)
- (F) UPPER MATTRESS FRAME
- (G) LOWER MATTRESS FRAME
- (H) RIGHT HINGE
- (I) LEFT HINGE
- (J) C HOOK
- (K) 5TH LEG

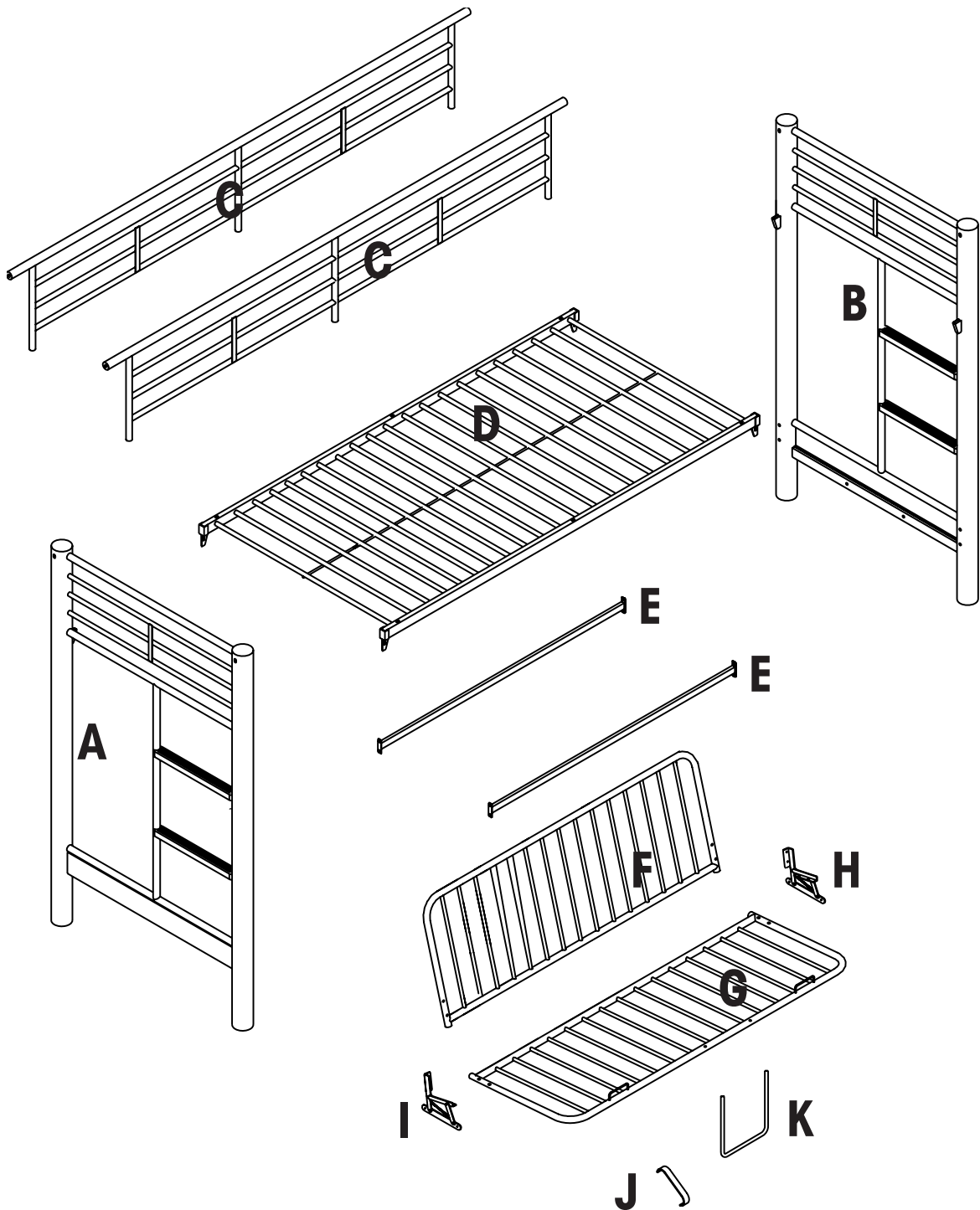

HARDWARE

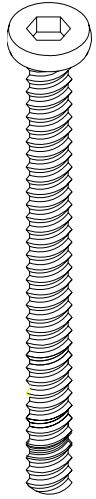

L
(4 PCS)

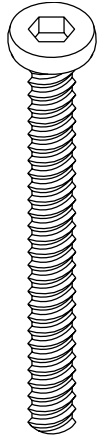

M
(6 PCS)

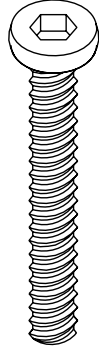

N
(12 PCS)

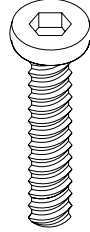

O
(8 PCS)

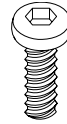

P
(4 PCS)

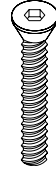

Q
(2 PCS)

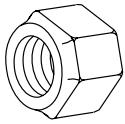

R
(12 PCS)

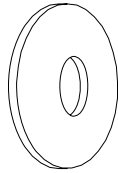

S
(4 PCS)

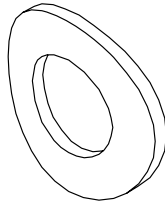

T
(4 PCS)

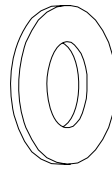

U
(26 PCS)



V
(8 PCS)

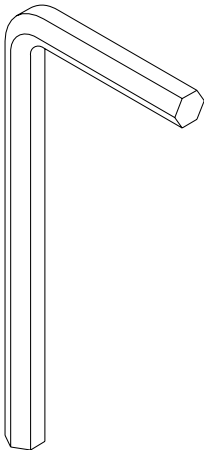

W
(1 PC)

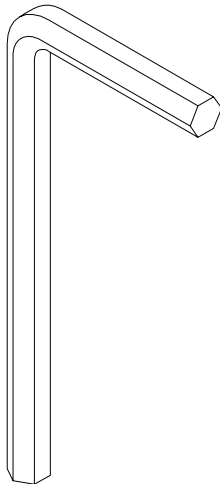

X
(1 PC)



Y
(4 PCS)

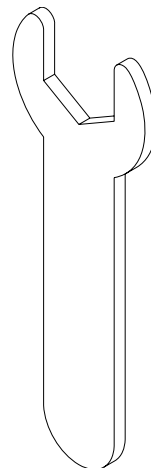

Z
(1 PC)

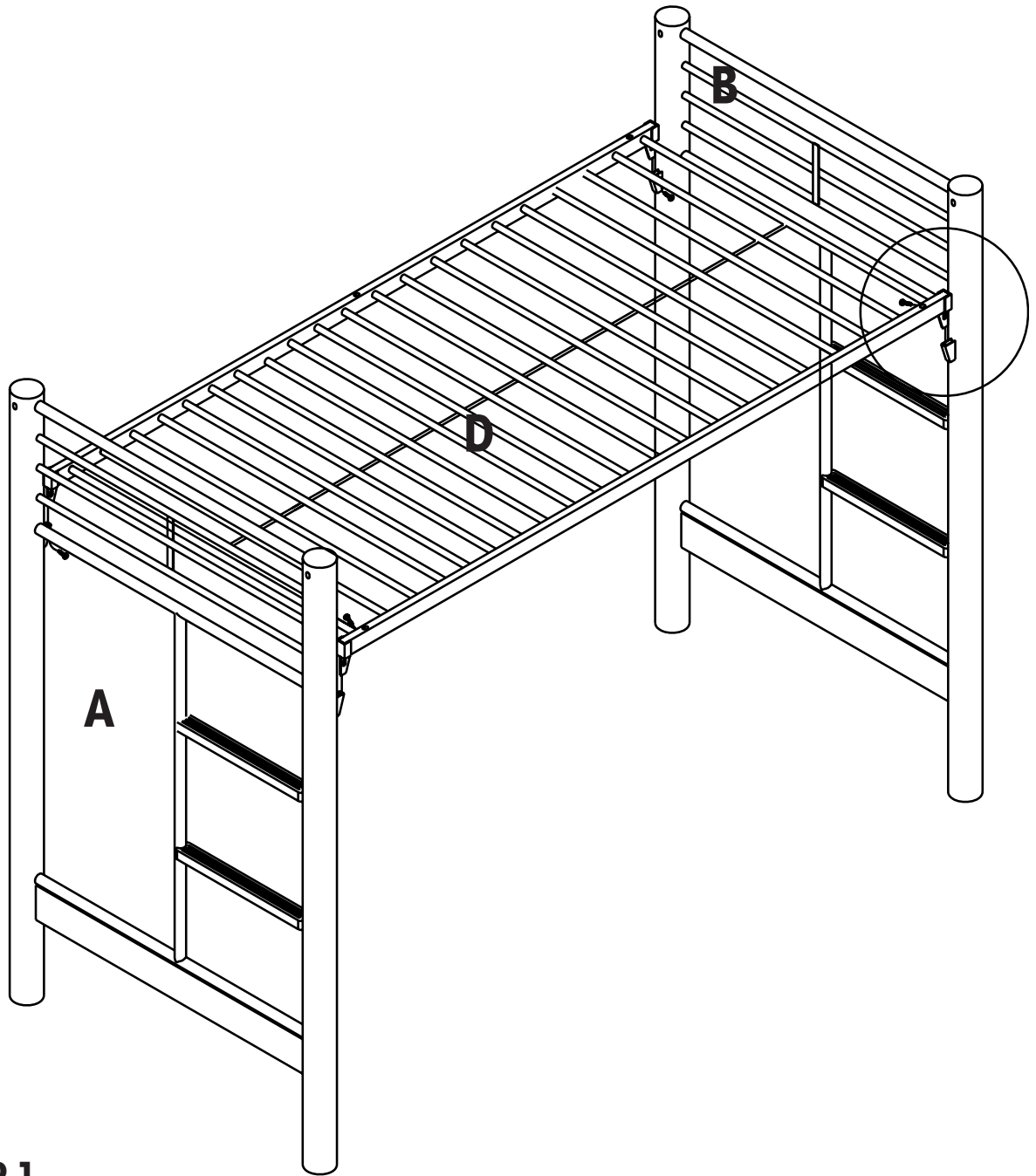

STEP 1

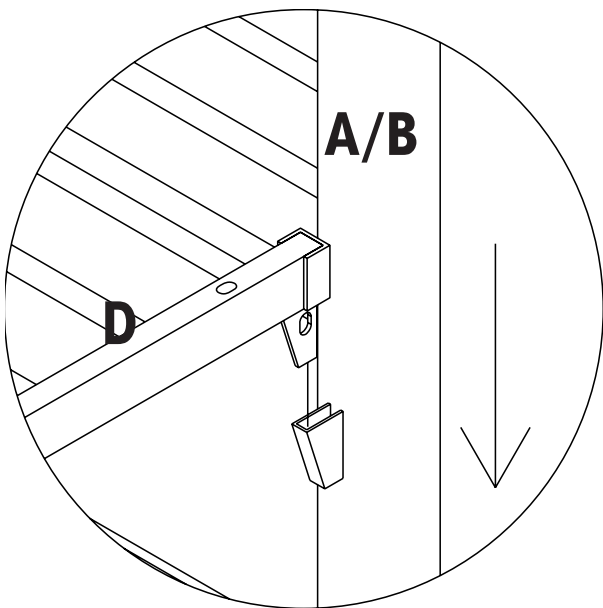

STEP 2

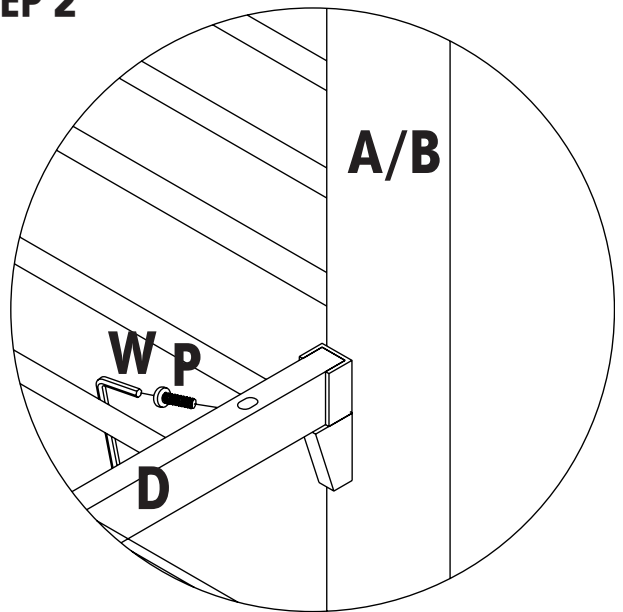

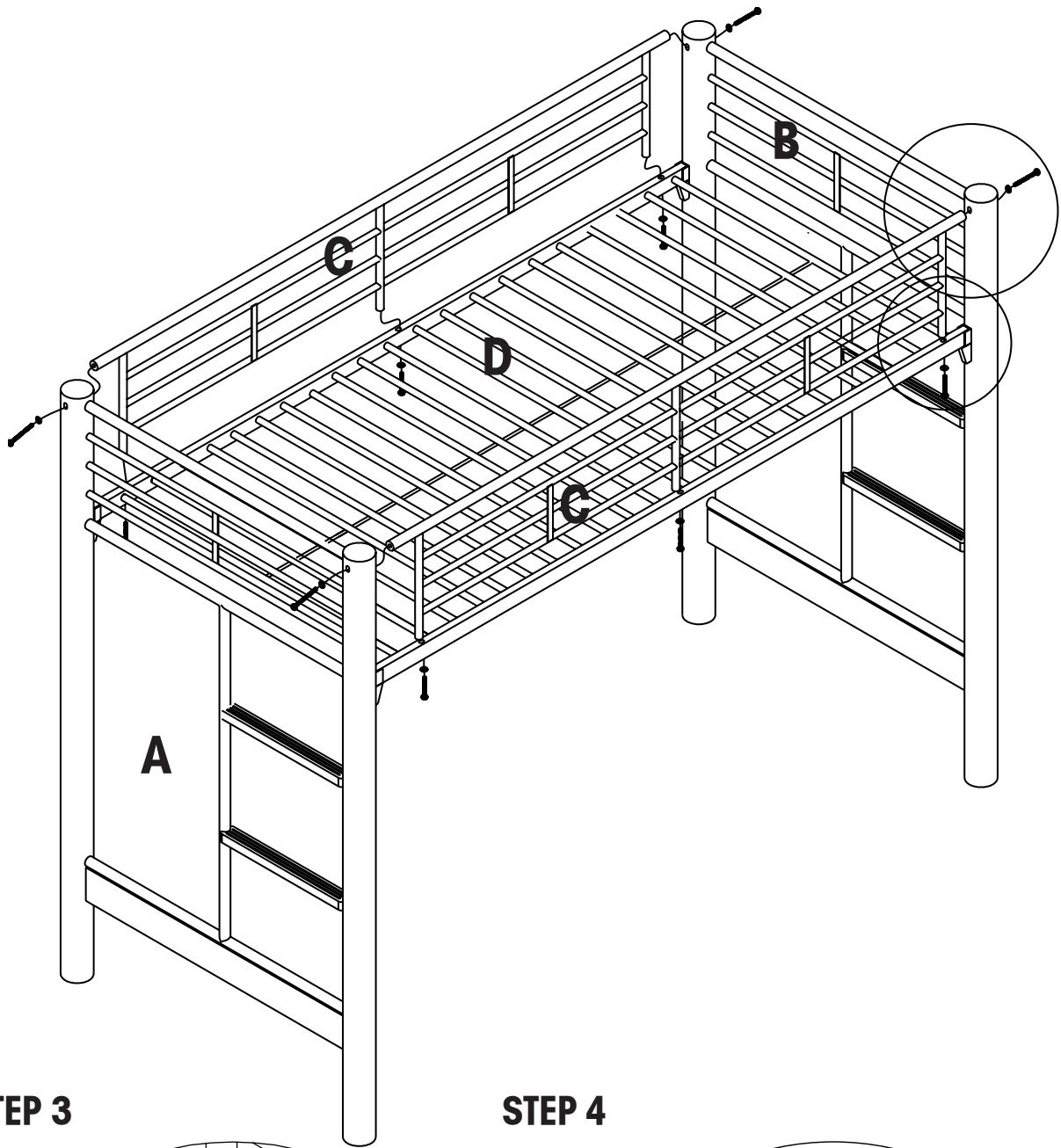

STEP 3

STEP 4

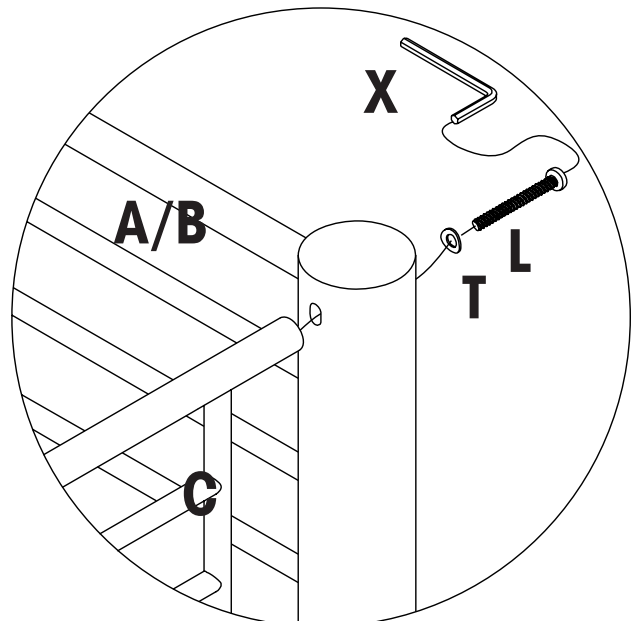
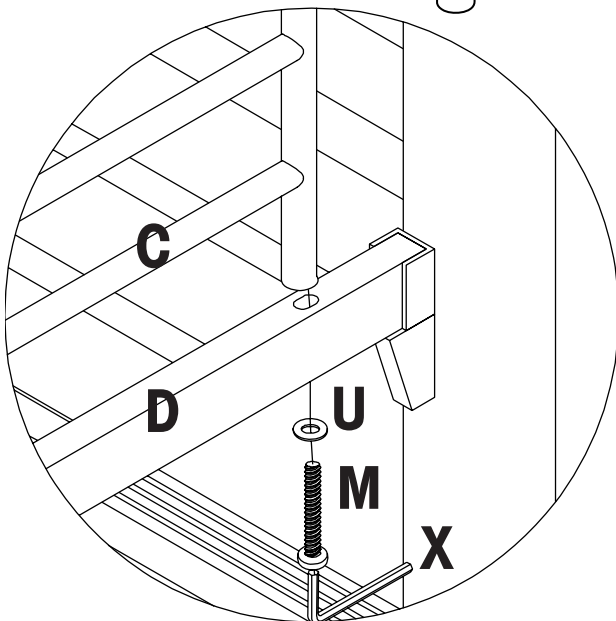

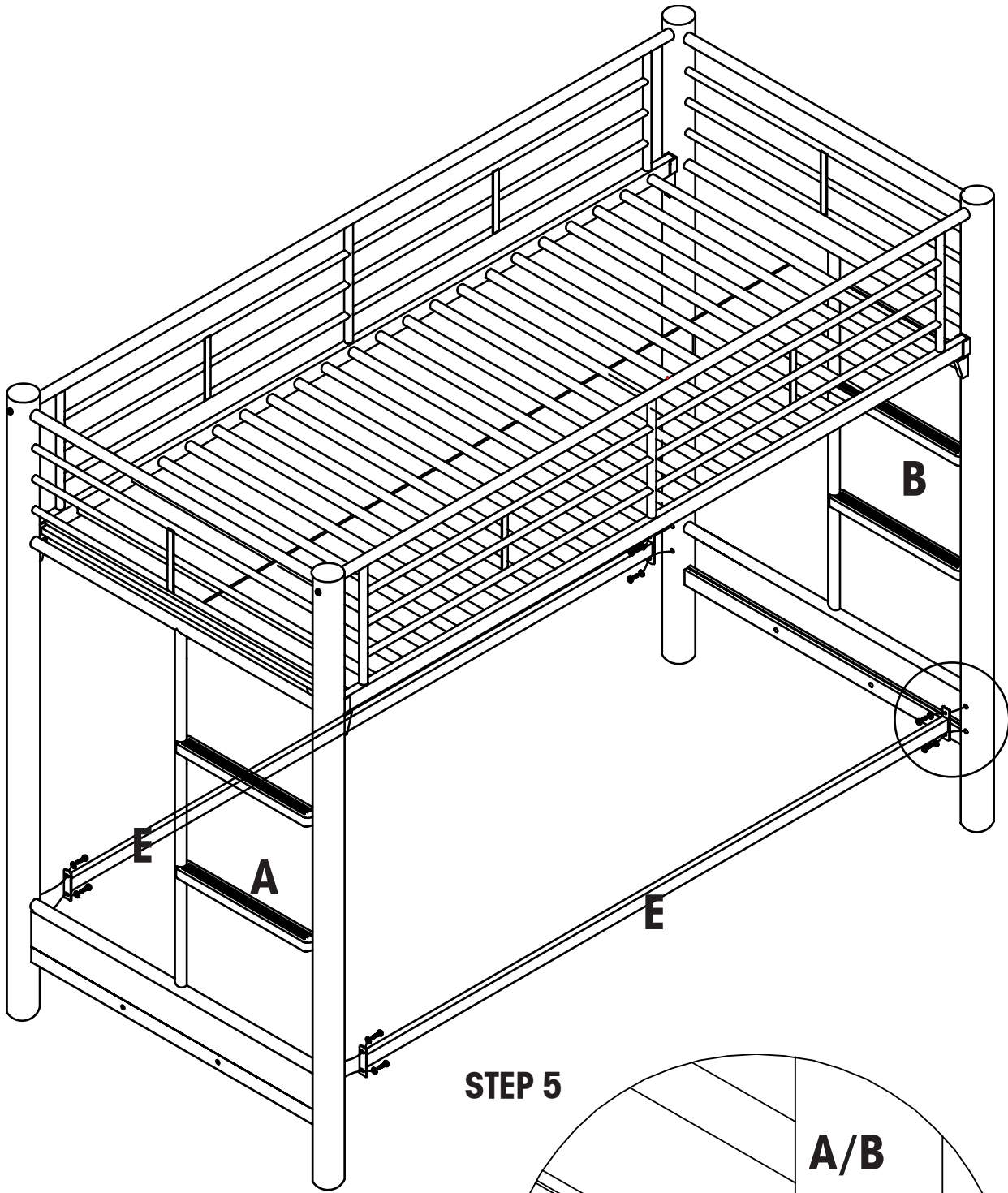

STEP 5

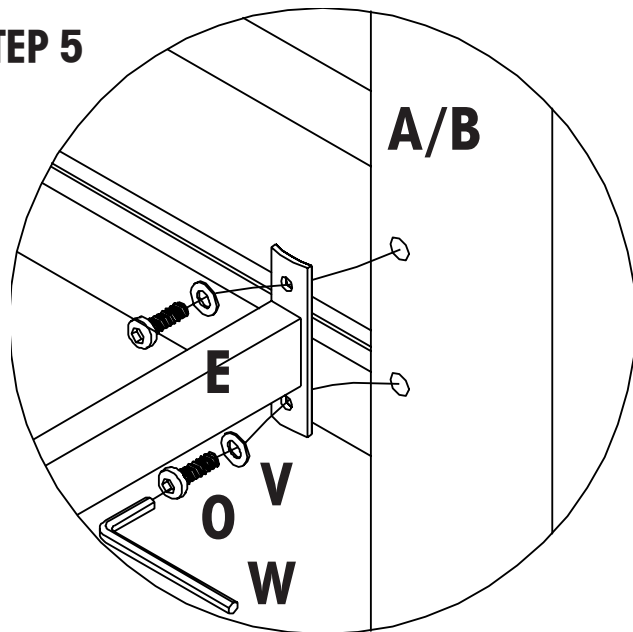

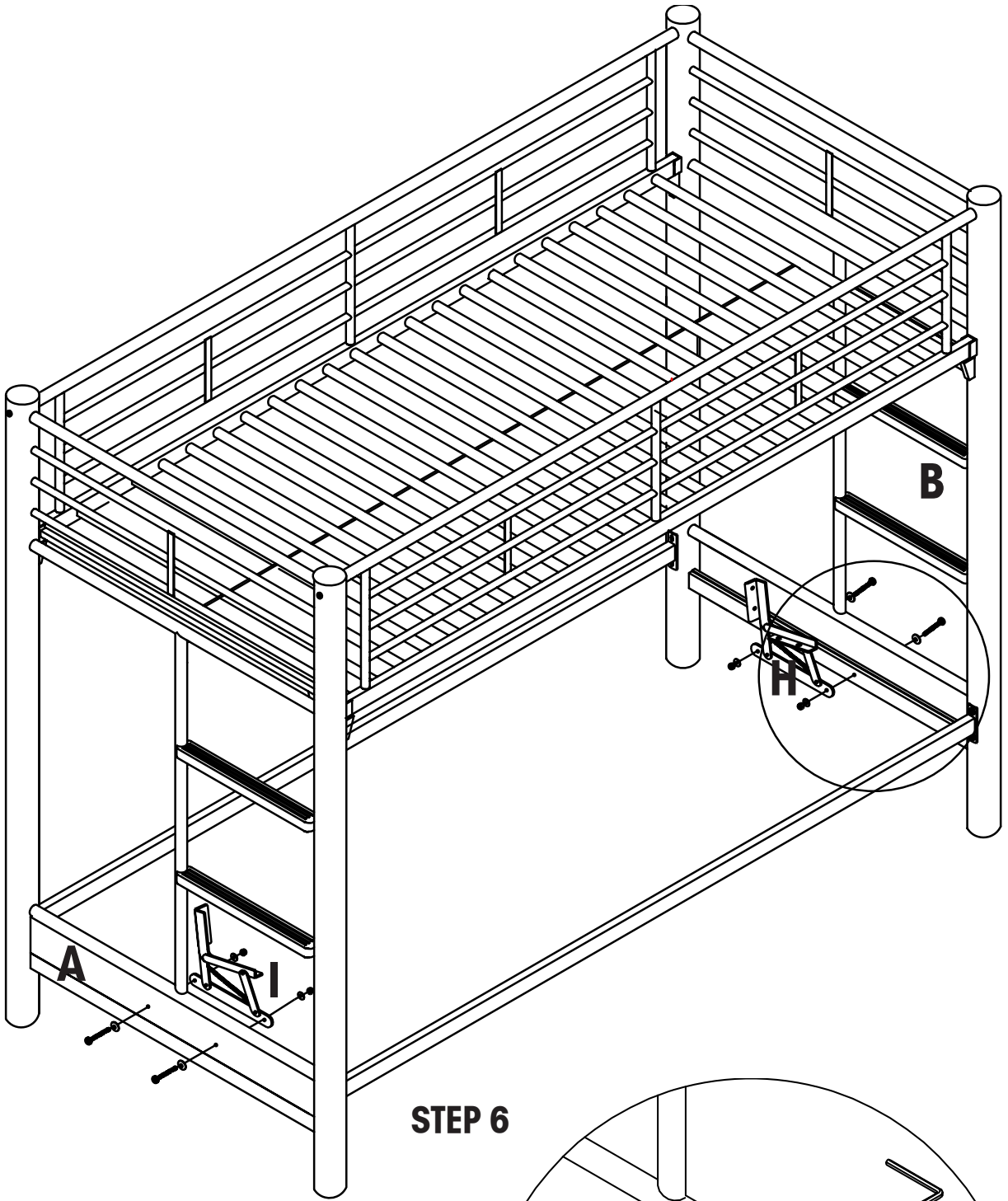

STEP 6

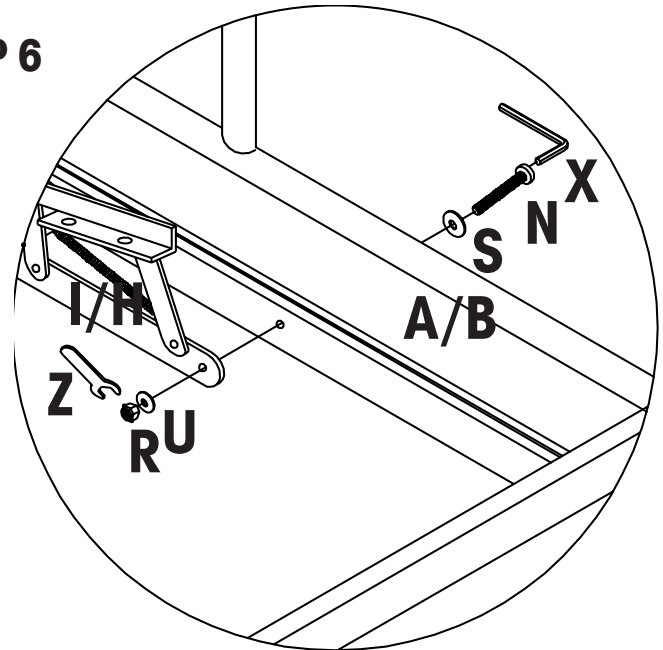

STEP 7

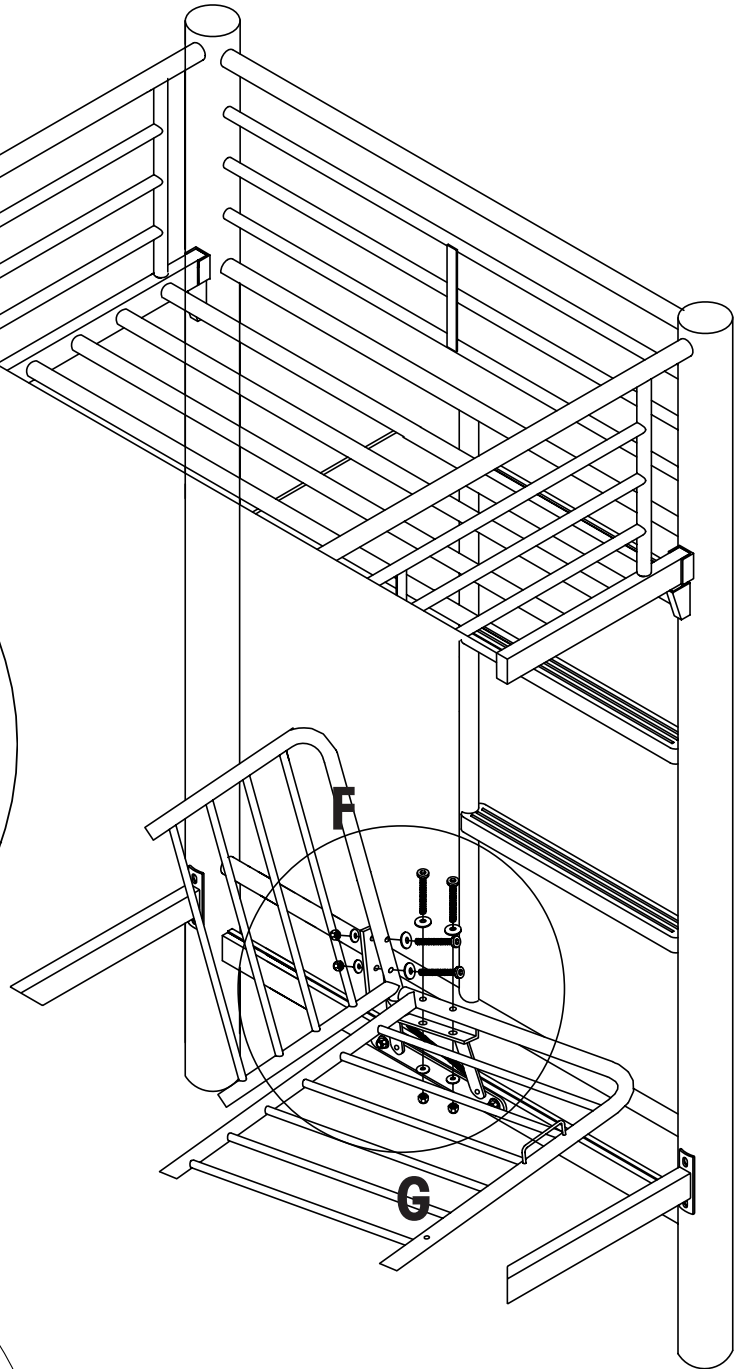
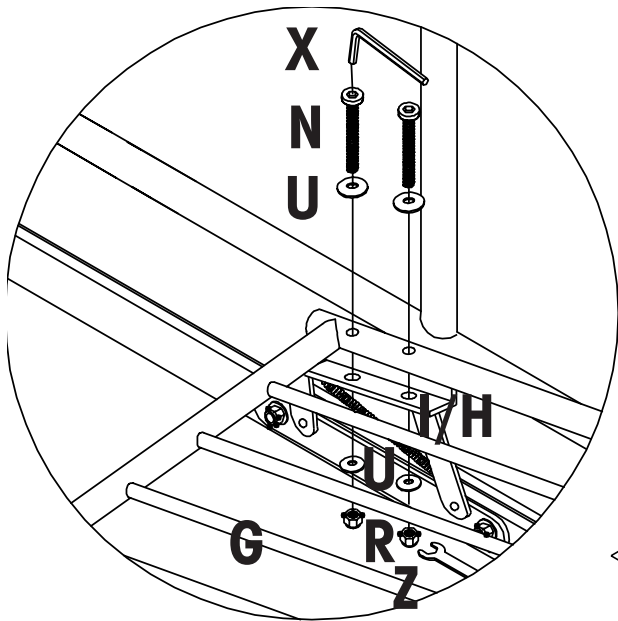

STEP 8

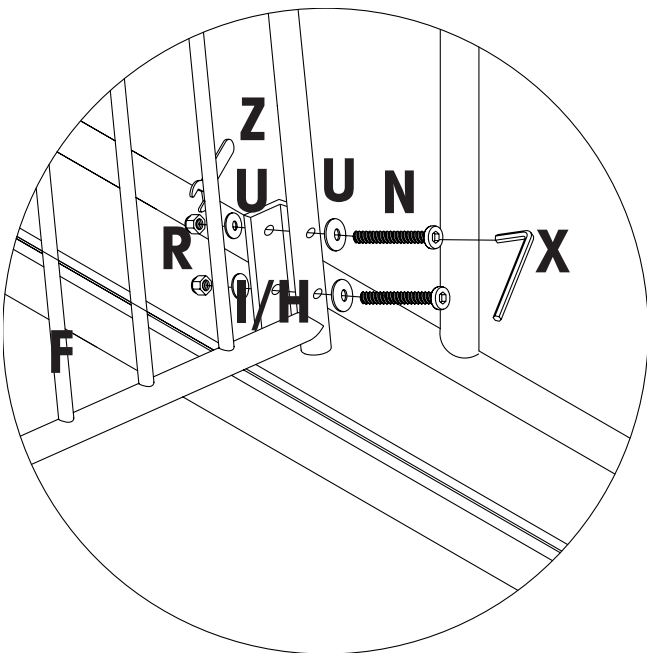

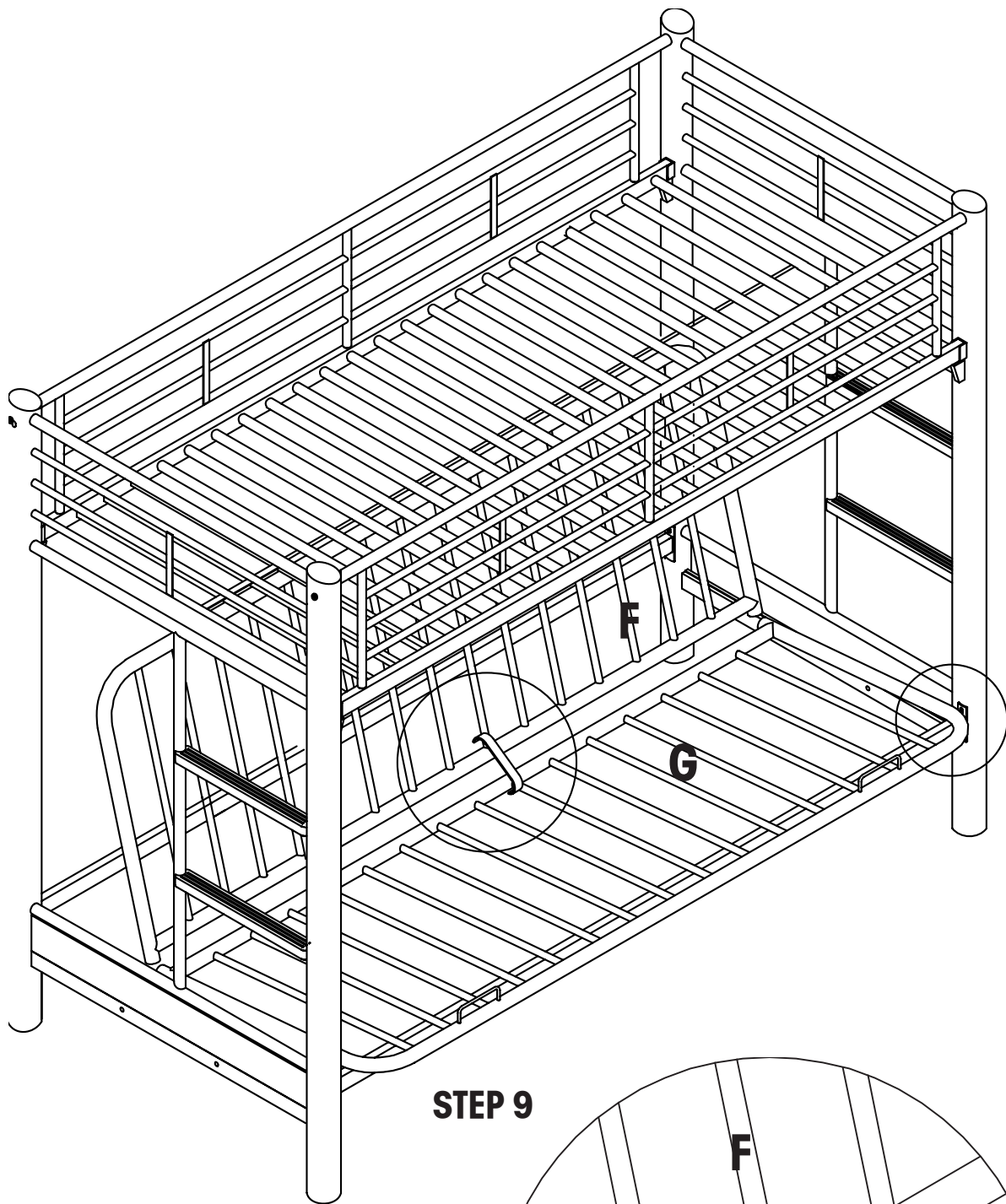

STEP 9

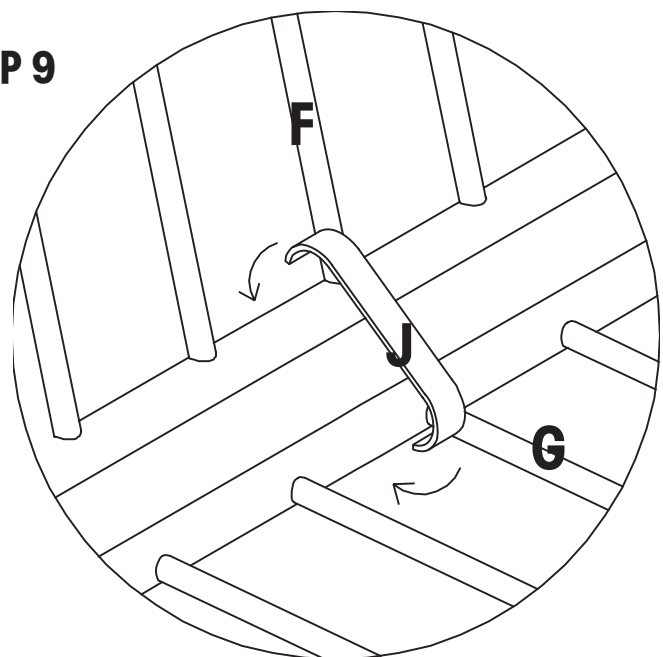

STEP 10

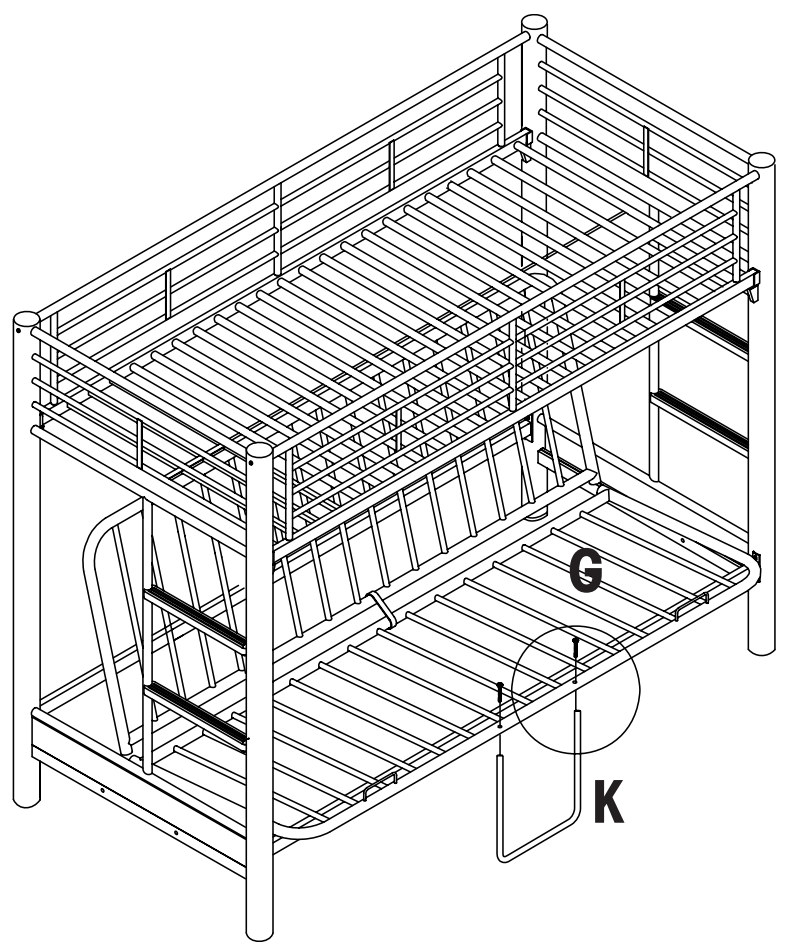
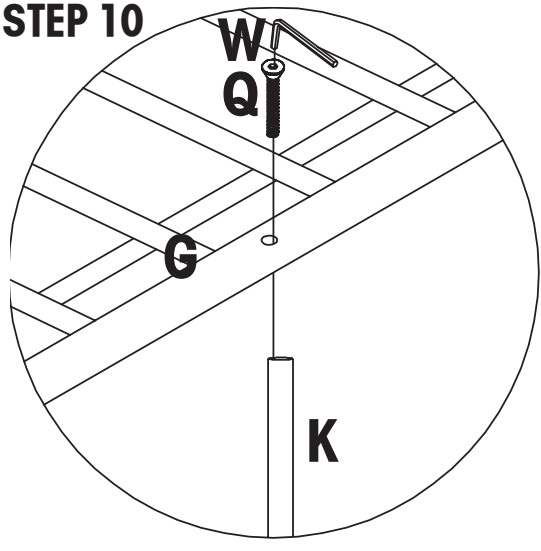

STEP 11

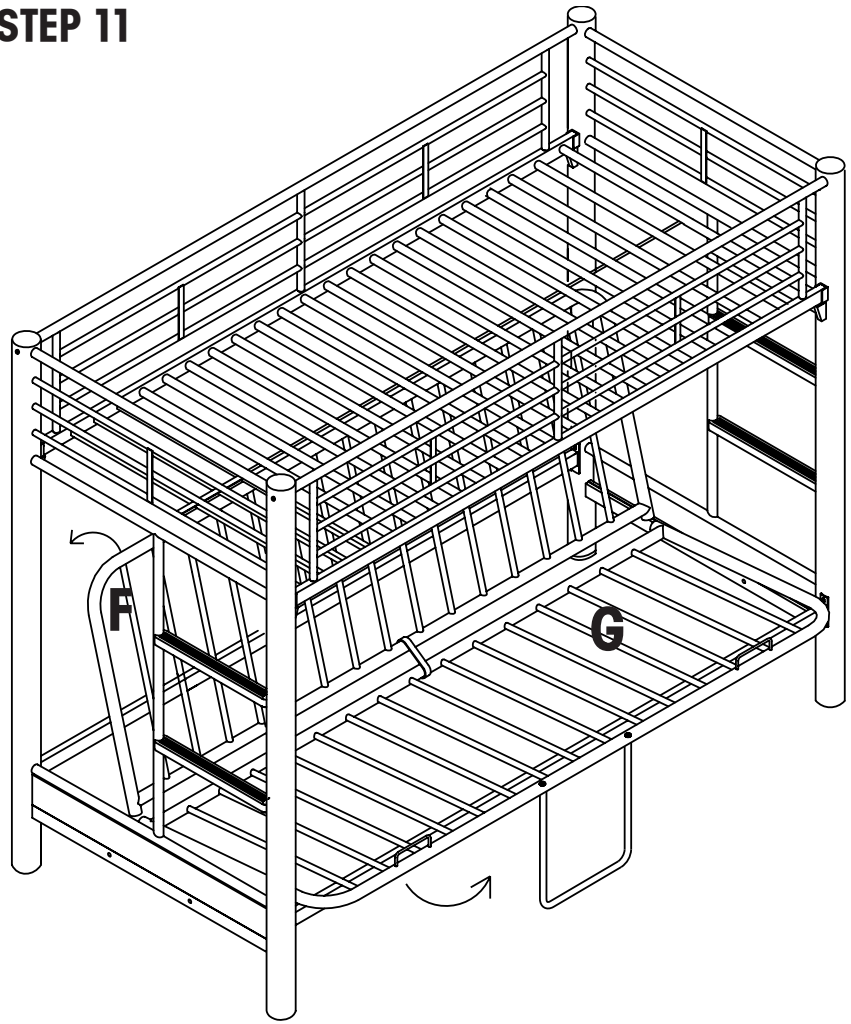

STEP 12

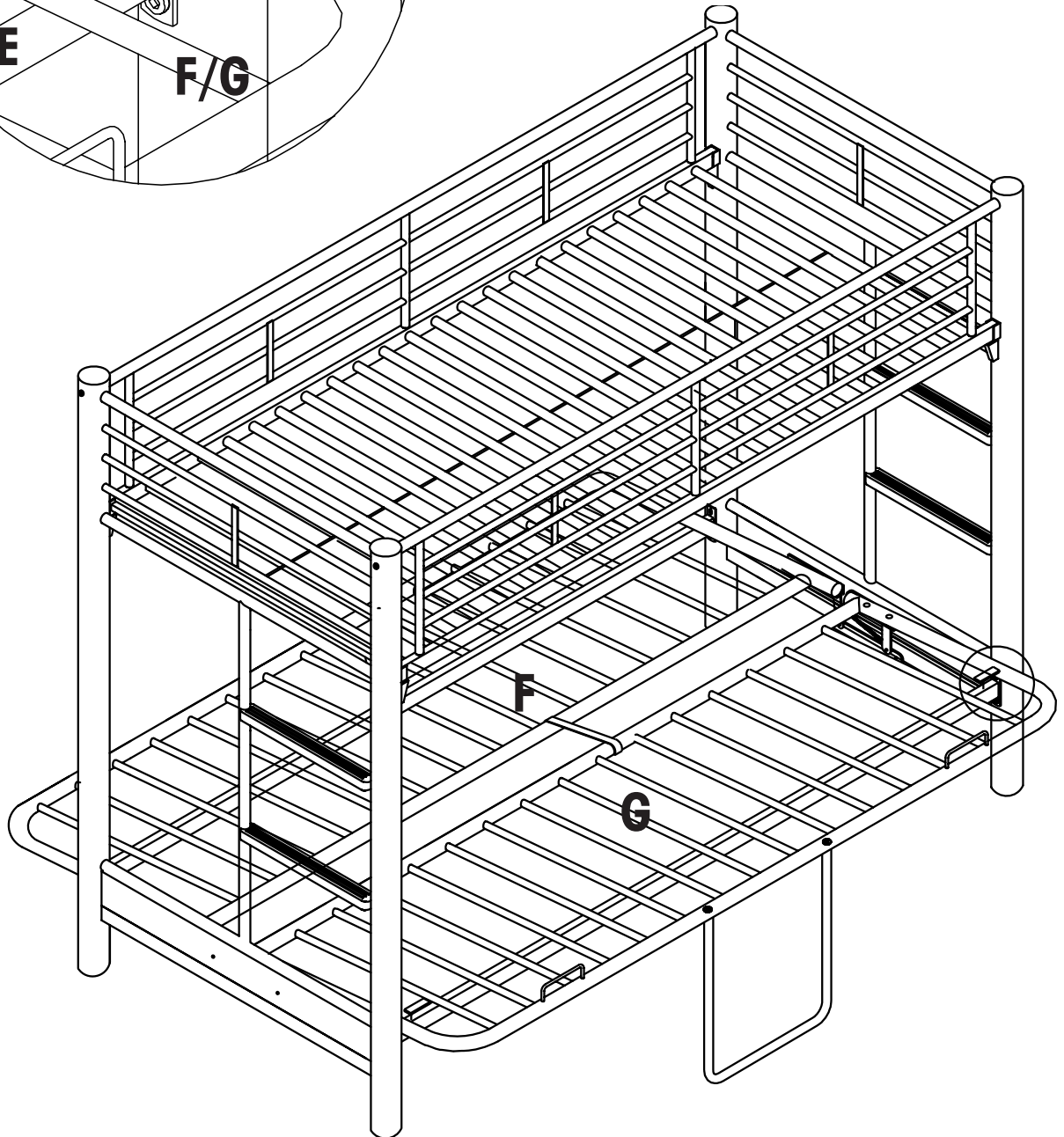
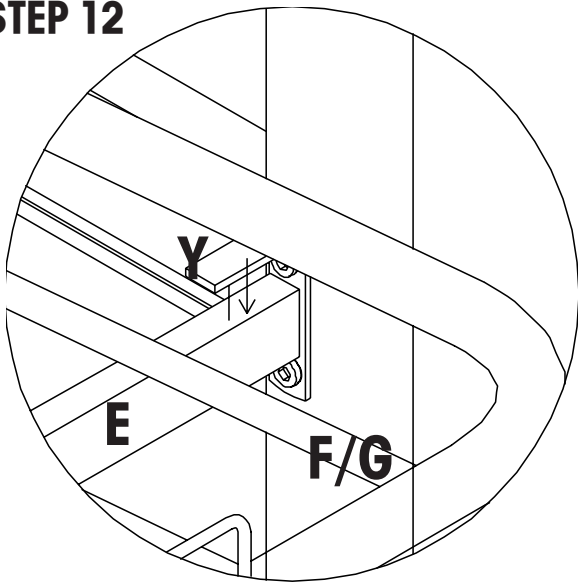

FOLLOW THE INFORMATION ON THE WARNING APPEARING ON THE UPPER BUNK END STRUCTURE AND ON THE CARTON. DO NOT REMOVE WARNING LABEL FROM BED. KEEP THESE INSTRUCTIONS FOR FUTURE REFERENCE.



WARNING TO HELP PREVENT SERIOUS OR FATAL INJURIES FROM ENTRAPMENT OR FALLS:

- Never allow a child under 6 years old on the upper bunk.
- Always use the recommended size mattress or mattress support, or both, to help prevent the likelihood of entrapment or falls.
- Use only a mattress which is 74" - 75" long and 37-1/2" - 38-1/2" wide on the upper bunk.
- Ensure thickness of mattress does not exceed 8" and surface of mattress is at least 5" below upper edge of guardrails.
- Always use guardrails on both long sides of the upper bunk.
- If bunk bed will be placed next to a wall, the guardrail that runs the full length of the bed should be placed against the wall to prevent entrapment between the bed and the wall.
- Prohibit horseplay on or under bed(s) and prohibit jumping on the bed.
- Prohibit more than one person on upper bunk.
- Use ladder for entering and leaving upper bunk.
- Maximum total weight is not to exceed 300 lbs. on the upper bunk.
- Periodically check and ensure that the guardrail, ladder, and other components are in their proper position, free from damage, and that all connectors are tight.
- Do not use substitute parts. Replacement parts, including additional guardrails, may be obtained from our customer service department.
- Use of water or sleep flotation mattresses is prohibited.
- Use of a night light may provide added safety precaution for a child using the upper bunk.

STRANGULATION HAZARD Never attach or hang items to any part of the bunk bed that are not designed for use with the bed; for example, but not limited to, hooks, belts and jump ropes.

DO NOT REMOVE THIS LABEL

IF YOU HAVE A PROBLEM, WE WANT TO HAVE THE OPPORTUNITY TO MAKE IT RIGHT!

Should there be any missing or defective part(s),

Fax this form to (310) 841-0842

or call Customer Service at (800) 622-4456 or (310) 204-2224

Have your model number and part code letter handy.

MODEL NO. 938-076

© 2006 Powell

Part Letter Description Quantity

Name _____

Address _____

Daytime Phone () _____

Reason for replacement _____

Place of purchase _____