

Made in China

Thank you for purchasing this quality product. Be sure to check all packing material carefully for small parts which may have come loose inside the carton during shipment. Separate, identify, and count all parts and metal hardware. Compare with parts list and hardware illustrations to be sure all parts are present. If any part(s) are missing or damaged, phone, fax, or mail to our Customer Service Department. For efficient and speedy service, please indicate the model number and code letter of part(s) needed.

ATTENTION: SOME LETTERED PARTS LISTED ON THE INSTRUCTION SHEET MAY NOT BE IN PARTS BAG AS THEY MAY ALREADY BE ASSEMBLED. CAREFULLY CHECK PARTS AND PACKING MATERIALS PRIOR TO ORDERING REPLACEMENTS. PRODUCT MUST BE COMPLETELY ASSEMBLED BEFORE FULLY TIGHTENING NUTS.

Tools Required for assembly: Wrench (included)

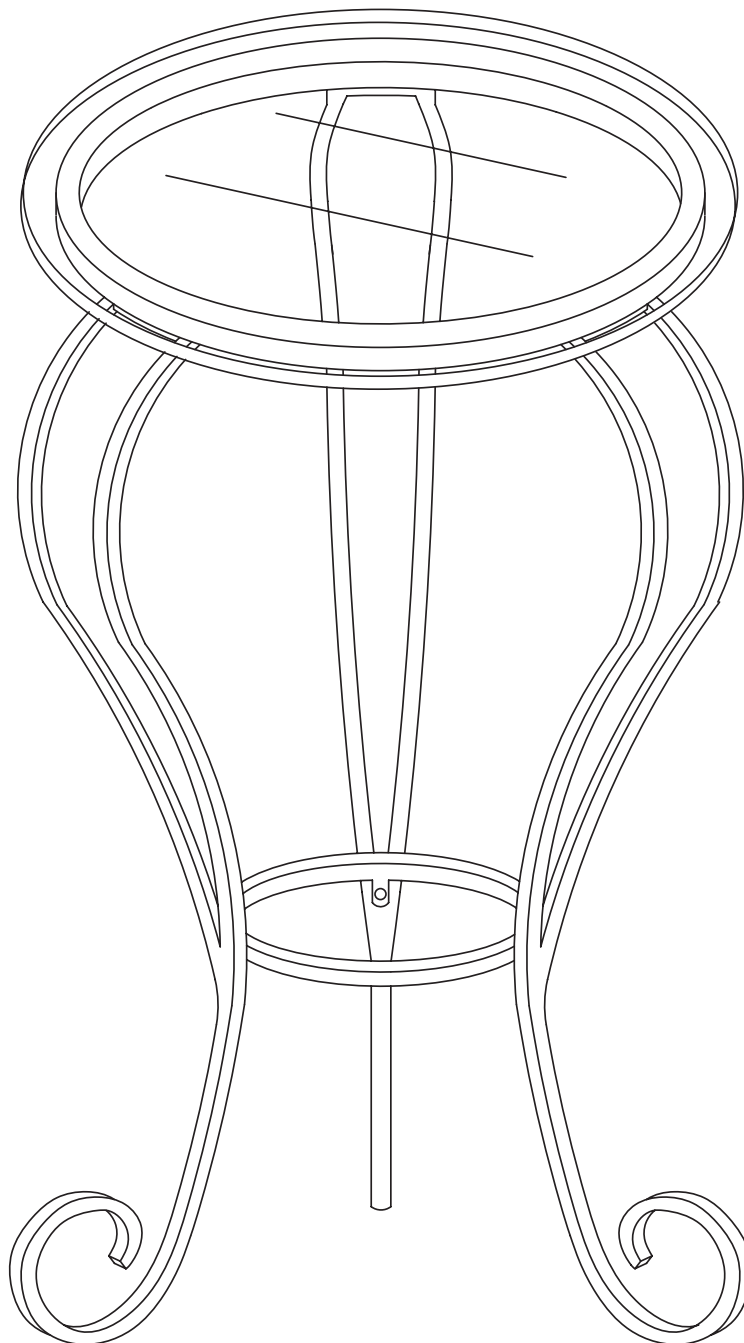

PARTS

(A) GLASS
(B) LEGS (3)

(C) BIG RING
(D) SMALL RING

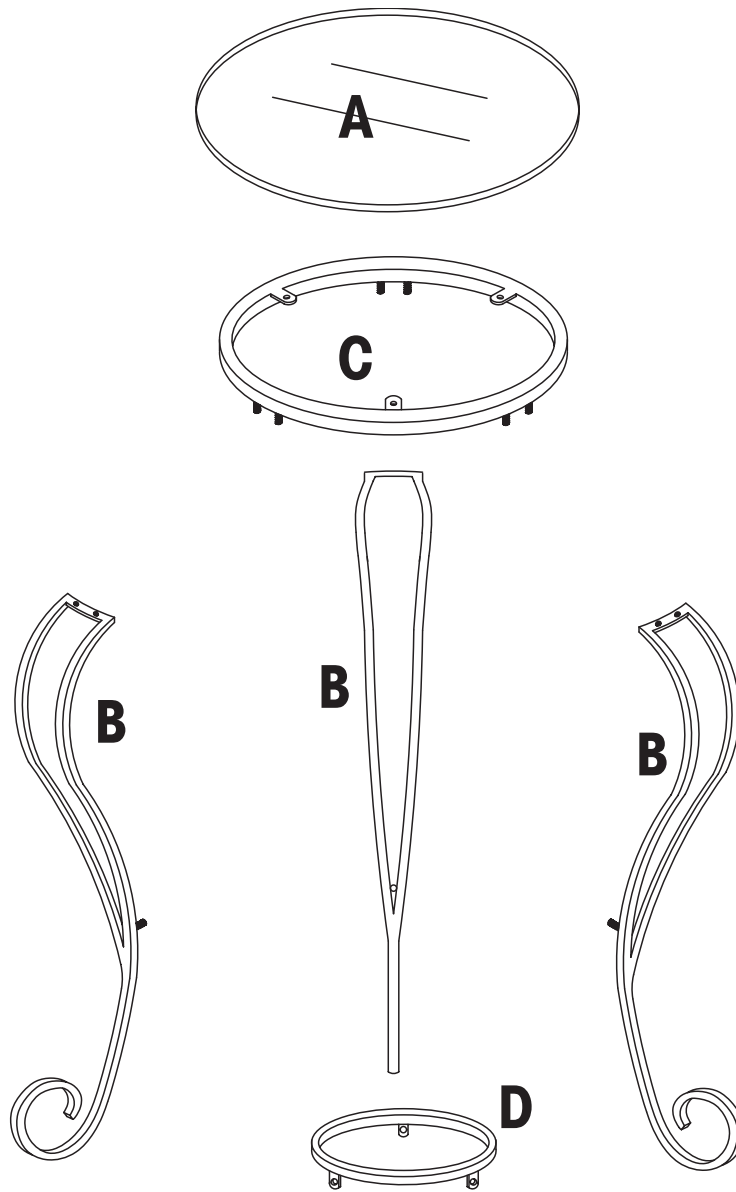

HARDWARE

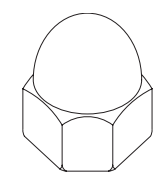

E
(9 PIECES)



F
(3 PIECES)

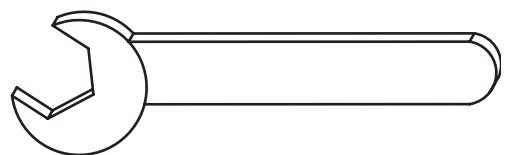

G
(1 PIECE)

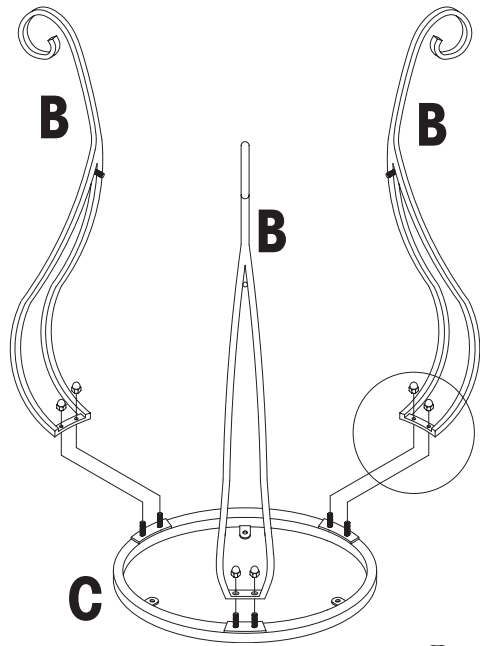

STEP 1

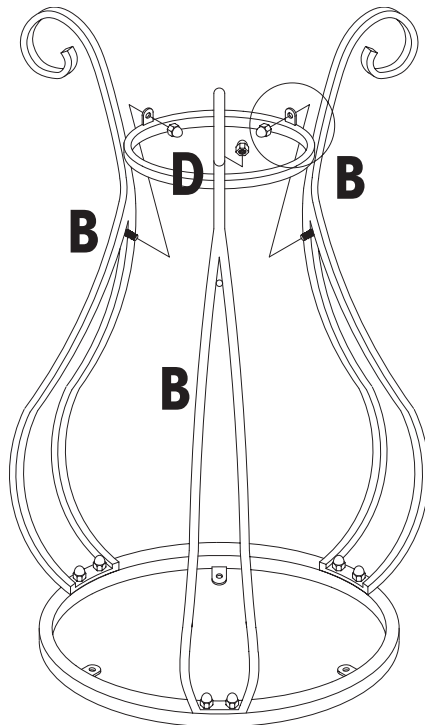
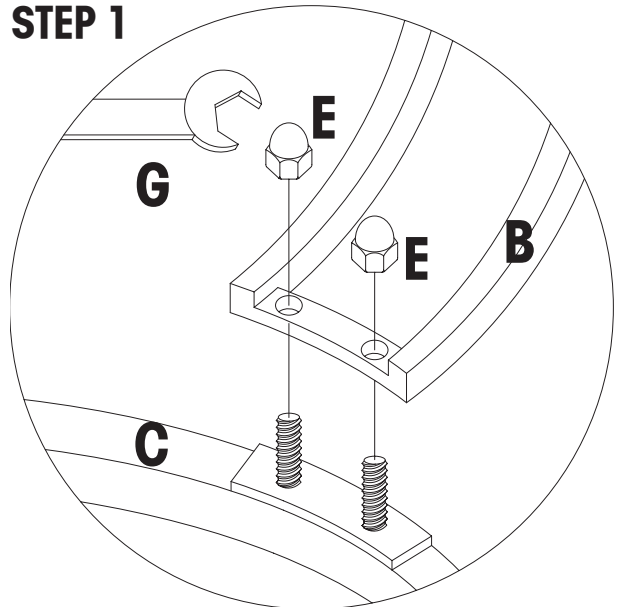

STEP 2

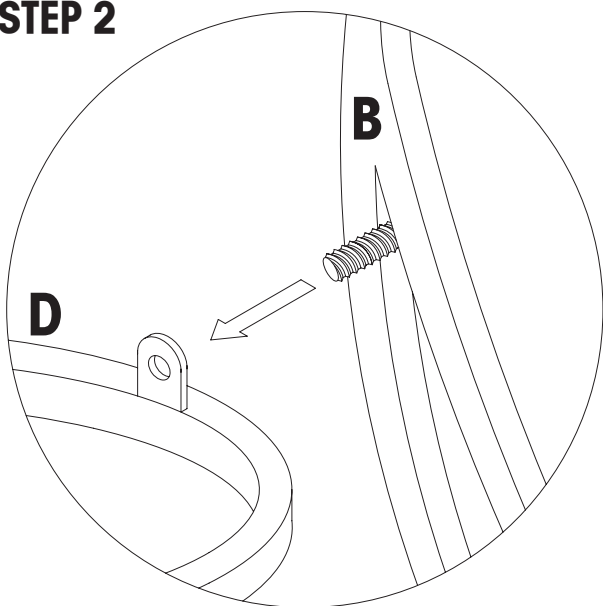

STEP 3

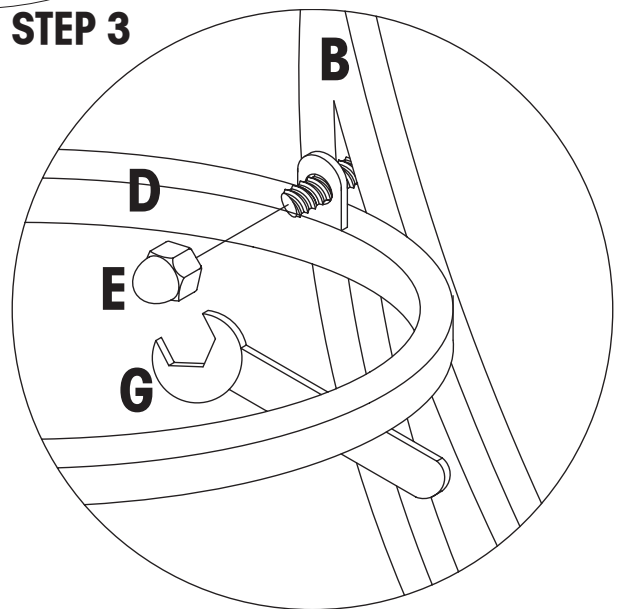

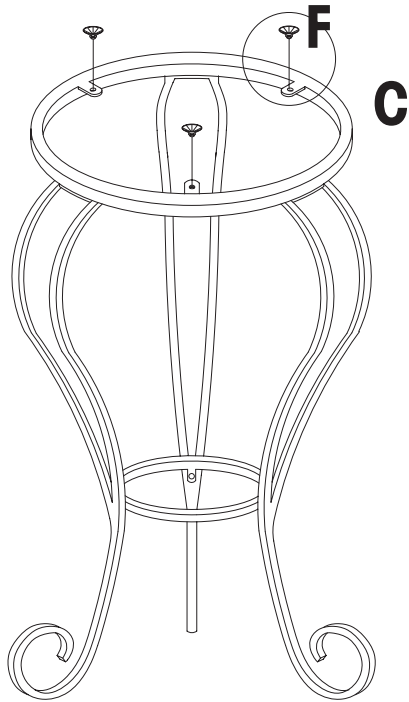

STEP 4

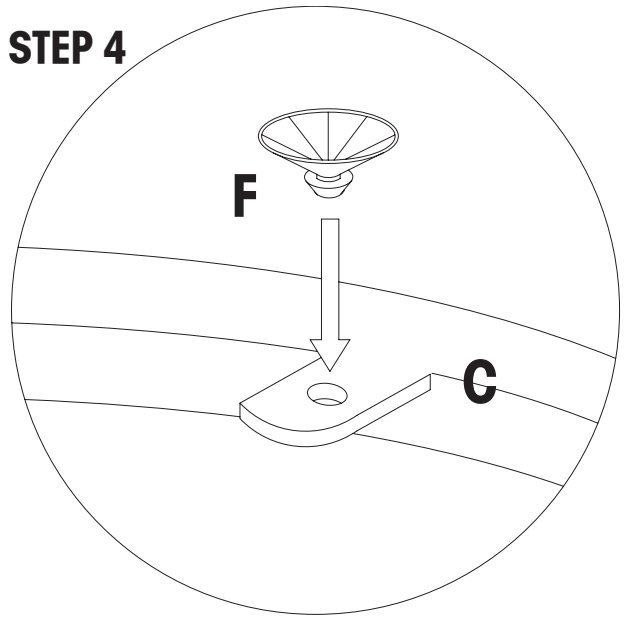

STEP 5

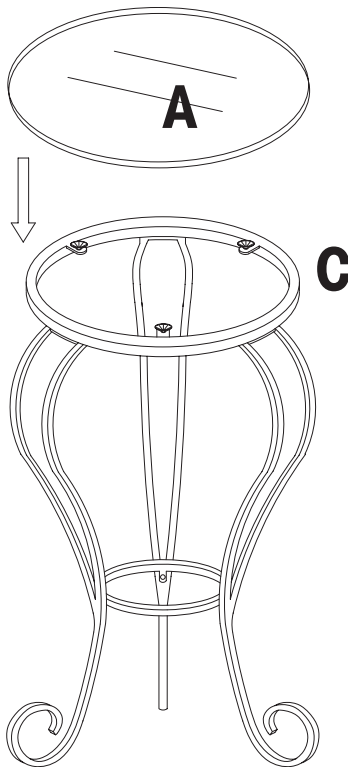

IF YOU HAVE A PROBLEM, WE WANT TO HAVE THE OPPORTUNITY TO MAKE IT RIGHT!

Should there be any missing or defective part(s),

Fax this form to (310) 841-0842

or call Customer Service at (310) 204-2224

Have your model number and part code letter handy.

MODEL NO. 935-269

© 2002 Powell

Part Letter _____ Quantity _____

Name _____

Address _____

Daytime Phone () _____

Reason for replacement _____

Place of purchase _____