

PARTS

- (A) END PANEL
- (B) LEGS (2)
- (C) BOLTS (4)
- (D) LOCK WASHERS (4)
- (E) METAL WASHERS (4)
- (F) PLASTIC WASHERS (4)
- (G) END CAPS (2)
- (H) FINIALS (2)

HARDWARE ILLUSTRATION

Tools required: Wrench

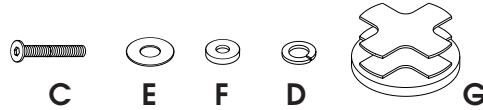

Thank you for purchasing this quality product. Be sure to check all packing material carefully for small parts which may have come loose inside the carton during shipment. Separate, identify, and count all parts and metal hardware. Compare with parts list to be sure all parts are present. If any part(s) are missing or damaged, phone, fax, or mail to our Customer Service Department. For efficient and speedy service, please indicate the model number and code letter of part(s) needed.

ATTENTION: SOME NUMBERED PARTS LISTED ON THE INSTRUCTION SHEET MAY NOT BE IN PARTS BAG AS THEY MAY ALREADY BE ASSEMBLED. CAREFULLY CHECK PARTS AND PACKING MATERIALS PRIOR TO ORDERING REPLACEMENTS.

IMPORTANT NOTE: Follow instructions listed below in the proper sequence as numbered to assure fast, easy and correct assembly.

TO ASSEMBLE AS HEADBOARD:

1. Place parts on a soft cloth. Insert small end of Legs (B) into ends of End Panel (A). NOTE: Make sure that threaded plates attached to End Panel (A) are facing away from mattress as you will be using plates welded to Legs (B) to assemble mattress frame to headboard. Insert Finials (H) into top of End Panels (A). Insert End Caps (G) into bottom of Legs (B).

TO ASSEMBLE AS FOOTBOARD:

2. Insert End Caps (G) into bottom of End Panel (A).
3. Insert Bolts (C) through Lock Washers (D), Metal Washers (E), bed frame (not included), Plastic Washers (F), and tighten into Legs (B) for use as headboard, or tighten into End Panel (A) if using as footboard.
4. To preserve your lustrous painted finish, wipe with a soft damp cloth. DO NOT use cleaners or abrasives as they may damage the finish.

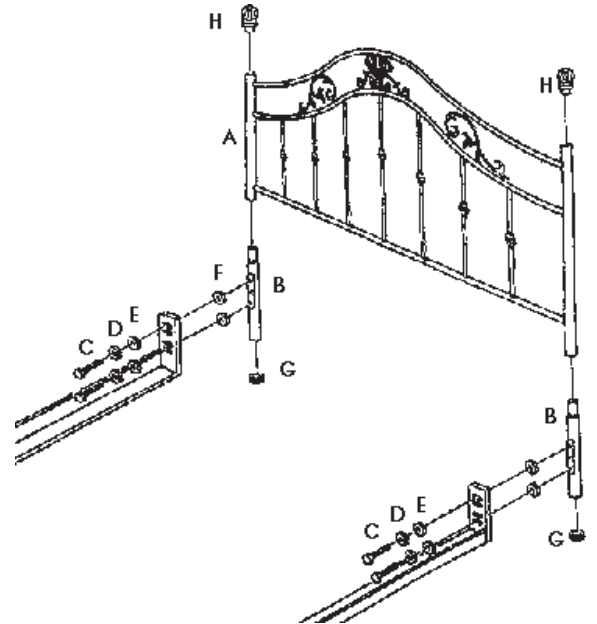

IF YOU HAVE A PROBLEM, WE WANT TO HAVE THE OPPORTUNITY TO MAKE IT RIGHT!

Should there be any missing or defective part(s),

FAX this form to (310) 841-0842

or call Customer Service at (800) 622-4456 or (310) 204-2224

Have your model number and part code letter handy.

MODEL NO. 905B Full
906B Queen
906B King

© 1996 Powell

Name _____

Address _____

Daytime Phone () _____

Reason for Replacement _____

Place of Purchase _____

Part Letter	Description	Quantity