

MODEL NO. 885 FULL

(or) **886** QUEEN

(or) **887** KING

ASSEMBLY INSTRUCTIONS (BU)

Thank you for purchasing this quality product. Be sure to check all packing material carefully for small parts which may have come loose inside the carton during shipment. Separate, identify, and count all parts and metal hardware. Compare with parts list to be sure all parts are present. If any part(s) are missing or damaged, phone, fax, or mail to our Customer Service Department. For efficient and speedy service, please indicate the model number and code letter of part(s) needed.

IMPORTANT NOTE: Follow instructions listed below in the proper sequence as numbered to assure fast, easy and correct assembly.

PARTS

- (A) END PANEL
- (B) LEGS (2)
- (C) END CAPS (2)
- (D) BOLTS (4)
- (E) LOCK WASHERS (4)
- (F) METAL WASHERS (4)
- (G) PLASTIC WASHERS (4)

HARDWARE ILLUSTRATION

Tools required: Wrench (not included)



ATTENTION: SOME NUMBERED PARTS LISTED ON THE INSTRUCTION SHEET MAY NOT BE IN PARTS BAG AS THEY MAY ALREADY BE ASSEMBLED. CAREFULLY CHECK PARTS AND PACKING MATERIALS PRIOR TO ORDERING REPLACEMENTS.

TO ASSEMBLE AS HEADBOARD:

1. Place parts on a soft cloth. Insert small end of Legs (B) into ends of End Panel (A). **NOTE:** Make sure that threaded plates attached to End Panel (A) are facing away from mattress as you will be using plates welded to Legs (B) to assemble mattress frame to headboard. Insert End Caps (C) into bottom of Legs (B). (See Ill. #1)

TO ASSEMBLE AS FOOTBOARD:

2. Insert End Caps (C) into bottom of End Panel (A).
3. Insert Bolts (D) through Lock Washers (E), Metal Washers (F), bed frame (not included), Plastic Washers (G), and tighten into Legs (B) for use as headboard, or tighten into End Panel (A) if using as footboard. (See ill. #2)
4. To preserve your lustrous painted finish, wipe with a soft damp cloth. **DO NOT** use cleaners or abrasives as they may damage the finish.

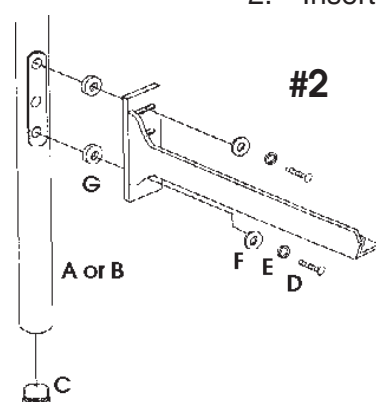
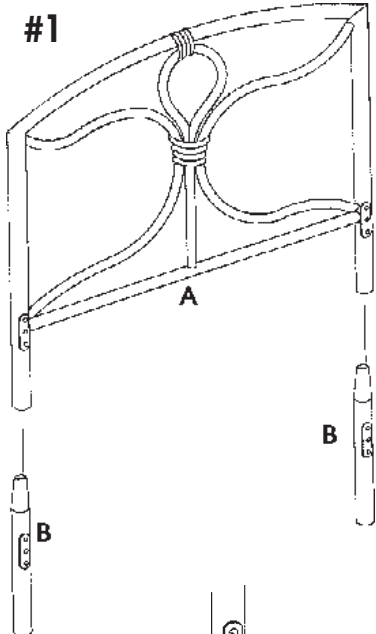

If you have a problem, we want to have the opportunity to make it right!

Should there be any missing or defective part(s),		© 1999
<u>PLEASE DO NOT RETURN THIS PRODUCT TO THE STORE</u>		Model No. <input type="checkbox"/> 885 Full
<i>(Many problems can be resolved without returning this product to the retailer)</i>		<input type="checkbox"/> 886 Queen
		<input type="checkbox"/> 887 King
FAX this form to (310) 841-0842		Name _____
or call Customer Service at (800) 622-4456 or (310) 204-2224		Address _____
Have your model number and part code letter handy.		Daytime Phone () _____
Part Letter	Description	Quantity
Part Letter	Description	Quantity
Part Letter	Description	Quantity
		Reason for Replacement _____
		Place of Purchase _____
P.O. Box 1408, Culver City, CA 90232-1408		Made in China