

# ASSEMBLY INSTRUCTIONS

# MODEL NO. 835W

Made in China

Thank you for purchasing this quality product. Be sure to check all packing material carefully for small parts which may have come loose inside the carton during shipment. Separate, identify, and count all parts and metal hardware. Compare with parts list to be sure all parts are present. If any part(s) are missing or damaged, phone, fax, or mail to our Customer Service Department. For efficient and speedy service, please indicate the model number and code letter of part(s) needed.

## PARTS

- |                             |                       |                              |
|-----------------------------|-----------------------|------------------------------|
| (A) RIGHT SIDE PANEL        | (J) WASHERS (8)       | (R) LARGE WOOD SCREWS (12)   |
| (B) LEFT SIDE PANEL         | (K) BACK              | (S) LARGE DOWELS (6)         |
| (C) SHELF                   | (L) TOP               | (T) DRAWER BOTTOM            |
| (D) CAM-BOLTS (12)          | (M) DRAWER BACK       | (U) HANDLES (2)              |
| (E) TURNBUCKLES (12)        | (N) RIGHT DRAWER SIDE | (V) SHORT MACHINE SCREWS (4) |
| (F) COVERS (12)             | (O) LEFT DRAWER SIDE  | (W) SMALL DOWELS (8)         |
| (G) BASE                    | (P) DRAWER FRONT      | (X) SMALL WOOD SCREWS (8)    |
| (H) LEGS (4)                | (Q) DIVIDERS (2)      | (Y) L-BRACKETS (4)           |
| (I) LONG MACHINE SCREWS (8) |                       |                              |

### HARDWARE ILLUSTRATION

Tools required: A screwdriver

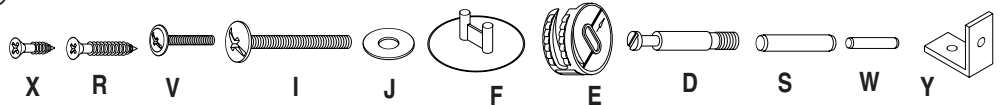

**ATTENTION:** SOME NUMBERED PARTS LISTED ON THE INSTRUCTION SHEET MAY NOT BE IN PARTS BAG AS THEY MAY ALREADY BE ASSEMBLED. CAREFULLY CHECK PARTS AND PACKING MATERIALS PRIOR TO ORDERING REPLACEMENTS.

**IMPORTANT NOTE:** Follow instructions listed below in the proper sequence as numbered to assure fast, easy and correct assembly.

- Note:** Upon opening, thoroughly clean all wood surfaces with furniture polish to remove dust and dirt that may have settled onto finish during shipment.
- Tighten Cam-bolts (D) into threaded inserts in Right and Left Side Panels (A,B). Insert Large Dowels (S) into middle holes on Right and Left Side Panels (A,B). Insert Turnbuckles (E) into large holes in Shelf (C). Rotate each Turnbuckle (E) with a flathead screwdriver until direction arrow points toward Cam-bolts (D). Insert Cam-bolts (D) and Large Dowels (S) extending from Side Panels (A,B) into ends of Shelf (C). Rotate Turnbuckles (E) clockwise to secure Side Panels (A,B) to Shelf (C). Note: Be sure groove on Sides (A,B) face inward. Push Covers (F) into slots in Turnbuckles (E). (See ill. #1)
- Place Base (G) upside down on a soft cloth. Insert Long Machine Screws (I) through Washers (J), through skirt of Base (G) and tighten into Legs (H). (See ill. #2)
- Tighten Cam-bolts (D) into threaded inserts in Base (G). Insert Large Dowels (S) into middle holes on Base (G). Insert Turnbuckles (E) along bottom edge of Side Panels (A,B). Align holes in bottom edge of Side Panels (A,B) with Cam-bolts (D) and Large Dowels (S) extending from Base (G) and press down. Rotate Turnbuckles (E) clockwise to secure Sides (A,B) to Base (G). Push Covers (F) into slots in Turnbuckles (E). (See ill. #2)
- Stand assembled Base (G) upright. Slide Back (K) into groove in Side Panels (A,B). Be sure that finished side of Back (K) faces forward. Insert Turnbuckles (E) into holes along top edge of Side Panels (A,B). Tighten Cam-bolts (D) into threaded inserts on underside of Top (L). Insert Large Dowels (S) into middle holes on Top (L). Insert Cam-bolts (D) and Large Dowels (S) extending from Top (L) into holes in Right and Left Side Panels (A,B). Rotate Turnbuckles (E) clockwise to secure Top (L) to Side Panels (A,B). (See ill. #3)

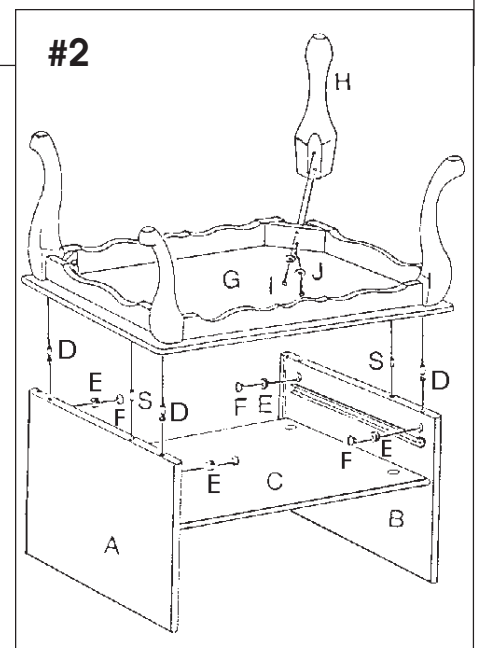
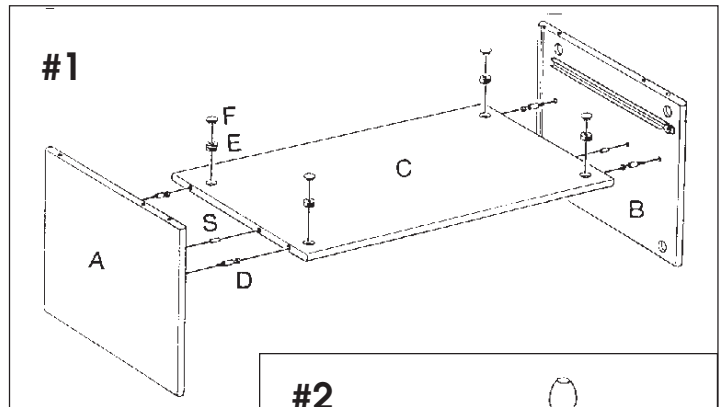

6. Insert Small Dowels (W) into ends of Dividers (Q). Insert Drawer Front (P) into lock bracket on Right Drawer Side (N) and secure by rotating screw on lock bracket clockwise. Repeat for Left Drawer Side (O). Be sure that groove on Drawer Front (P) aligns with groove on Right and Left Drawer Sides (N,O). (See ill #4)

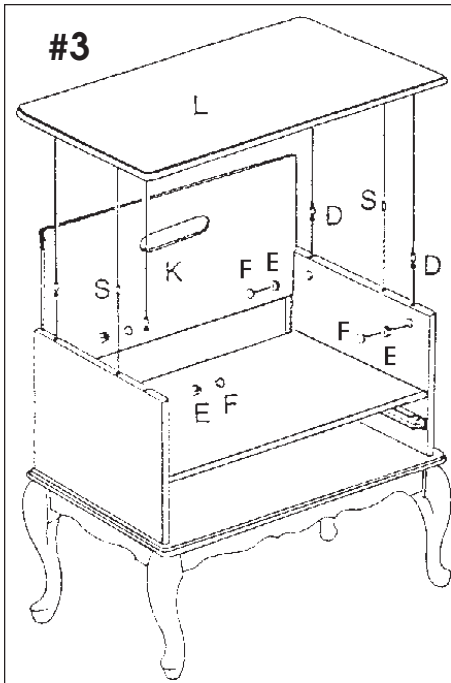

7. Slide Drawer Bottom (T) into groove on Right and Left Drawer Sides (N,O) and align with groove on Drawer Front (P). Be sure finished side of Drawer Bottom (T) faces upward. Insert Small Dowels (W) extending from Dividers (Q) into corresponding holes in Drawer Front (P). Be sure finished edge of Dividers (Q) is on top. (See ill. #4)

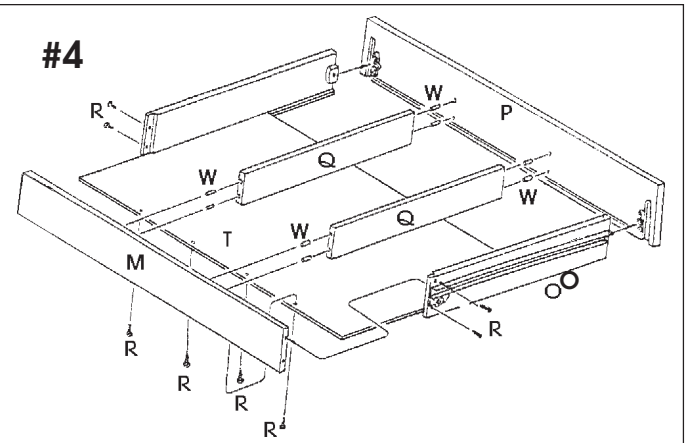

8. Align groove on Drawer Back (M) with Drawer Bottom (T) and insert Small Dowels (W) extending from Dividers (Q) into corresponding holes in Drawer Back (M). Tighten Large Wood Screws (R) through Drawer Sides (N,O) and into ends of Drawer Back (M). Insert Large Wood Screws (R) through Drawer Bottom (T) and tighten into bottom edge of Drawer Back (M). (See ill. #4)

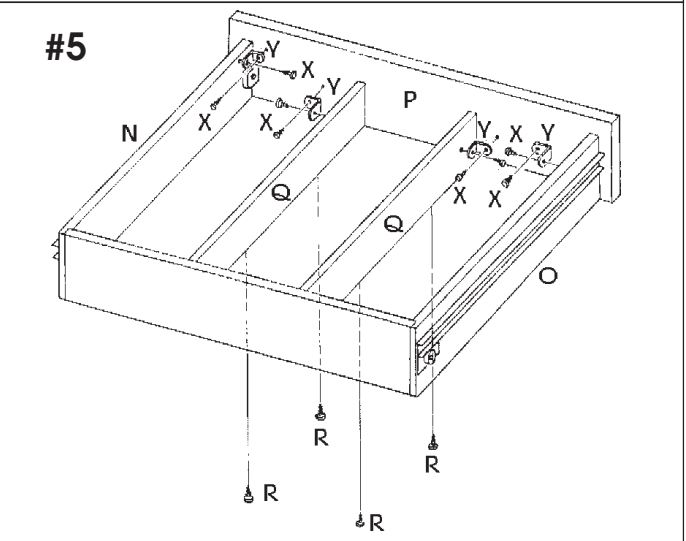

9. Insert Short Wood Screws (X) through ends of L-brackets (Y) and tighten into Drawer Sides (N,O) just above lock bracket, and tighten into Drawer Front (P). Insert Short Wood Screws through ends of L-brackets (Y) and tighten into Dividers (Q) and Drawer Front (P). Tighten Long Wood Screws (R) through underside of Drawer Bottom (T) and tighten into bottom edge of Dividers (Q). (See ill. #5)

10. Insert Short Machine Screws (V) through Drawer Front (P) and tighten into Handles (U). Align drawer with drawer glides and slide assembled drawer into place. (See ill. #5)

11. Your furniture has been handcrafted and skillfully finished by fine craftsmen. Rich, deep antique finishes have been applied which require very little polish. However, should you desire a shinier finish, simply use any good grade of furniture polish, rubbing the finish lightly as it is being applied. Allow to dry and buff lightly with a soft cloth.

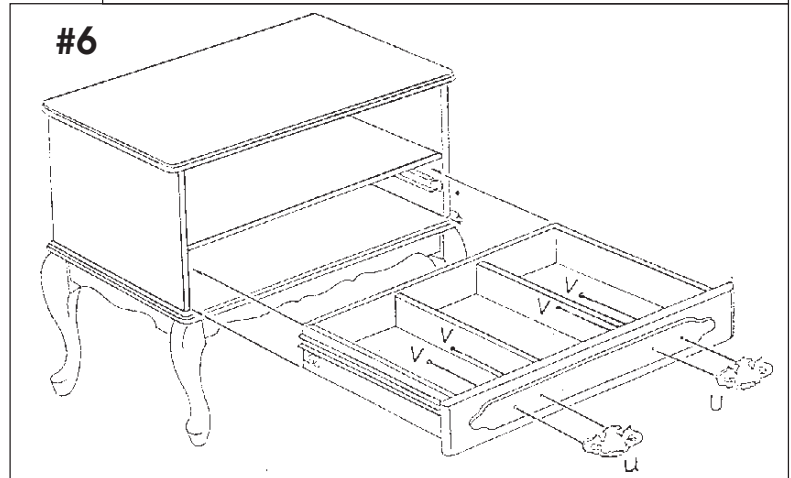

***If you have a problem, we want to have the opportunity to make it right!***

Should there be any missing or defective part(s),  
**PLEASE DO NOT RETURN THIS PRODUCT TO THE STORE**

**Model No.**  
**835W**

*(Many problems can be resolved without returning this product to the retailer)*

**FAX this form to (310) 841-0842**

or call Customer Service at (800) 622-4456 or (310) 204-2224  
 Have your model number and part code letter handy.

Name \_\_\_\_\_

Address \_\_\_\_\_

Daytime Phone ( ) \_\_\_\_\_

Reason for Replacement \_\_\_\_\_

Place of Purchase \_\_\_\_\_

Part Letter	Description	Quantity