

# MODEL NO. 694 FULL

(or) 695 QUEEN

(or) 696 KING

## ASSEMBLY INSTRUCTIONS

Thank you for purchasing this quality product. Be sure to check all packing material carefully for small parts which may have come loose inside the carton during shipment. Separate, identify, and count all parts and metal hardware. Compare with parts list to be sure all parts are present. If any part(s) are missing or damaged, phone, fax, or mail to our Customer Service Department. For efficient and speedy service, please indicate the model number and code letter of part(s) needed.

**IMPORTANT NOTE:** Follow instructions listed below in the proper sequence as numbered to assure fast, easy and correct assembly.

### PARTS LIST

- |                  |                              |                         |
|------------------|------------------------------|-------------------------|
| (A) END PANEL    | (D) FINIALS (2)              | (G) METAL WASHERS (4)   |
| (B) LEGS (2)     | (E) LONG MACHINE SCREWS (4)  | (H) LOCK WASHERS (8)    |
| (C) END CAPS (2) | (F) SHORT MACHINE SCREWS (4) | (I) PLASTIC WASHERS (4) |

### HARDWARE ILLUSTRATION

Tools required: Wrench (not included)



**ATTENTION:** SOME NUMBERED PARTS LISTED ON THE INSTRUCTION SHEET MAY NOT BE IN PARTS BAG AS THEY MAY ALREADY BE ASSEMBLED. CAREFULLY CHECK PARTS AND PACKING MATERIALS PRIOR TO ORDERING REPLACEMENTS.

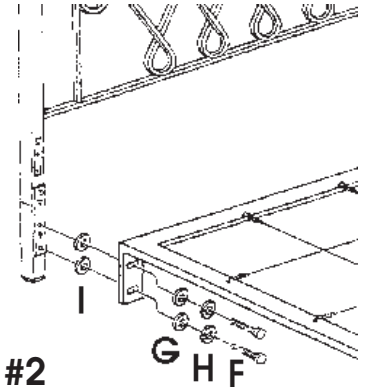

### TO ASSEMBLE AS HEADBOARD:

- Place parts on a soft cloth. Insert top of Legs (B) into bottom of End Panel (A). Insert Long Machine Screws (E) through Lock Washers (H), Legs (B) and tighten into End Panel (A). Insert End Caps (C) into bottom of Legs (B). Insert Finials (D) into top of End Panel (A). (See ill. #1)

### TO ASSEMBLE AS FOOTBOARD:

- Insert End Caps (C) into bottom of End Panel (A).
- Insert Short Machine Screws (F) through Lock Washers (H), Metal Washers (G), bed frame (not included), Plastic Washers (I), and tighten into Legs (B) for use as headboard, or tighten into End Panel (A) if using as footboard. (See ill. #2)
- To preserve your lustrous painted finish, wipe with a soft damp cloth. DO NOT use cleaners or abrasives as they may damage the finish.

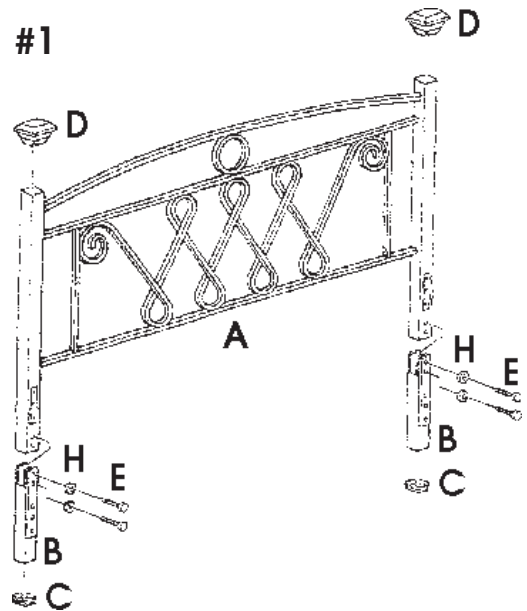

***If you have a problem, we want to have the opportunity to make it right!***

Should there be any missing or defective part(s),

**PLEASE DO NOT RETURN THIS PRODUCT TO THE STORE**

*(Many problems can be resolved without returning this product to the retailer)*

Model No.  694 Full  
 695 Queen  
 696 King

**FAX this form to (310) 841-0842**

or call Customer Service at (800) 622-4456 or (310) 204-2224  
Have your model number and part code letter handy.

Name \_\_\_\_\_

Address \_\_\_\_\_

Daytime Phone (     ) \_\_\_\_\_

Reason for Replacement \_\_\_\_\_

Place of Purchase \_\_\_\_\_

Part Letter	Description	Quantity

P.O. Box 1408, Culver City, CA 90232-1408

Made in Taiwan, R.O.C.