

Thank you for purchasing this quality product. Be sure to check all packing material carefully for small parts which may have come loose inside the carton during shipment. Separate, identify, and count all parts and metal hardware. Compare with parts list to be sure all parts are present. If any part(s) are missing or damaged, phone, fax, or mail to our Customer Service Department. For efficient and speedy service, please indicate the model number and code letter of part(s) needed.

ATTENTION: SOME NUMBERED PARTS LISTED ON THE INSTRUCTION SHEET MAY NOT BE IN PARTS BAG AS THEY MAY ALREADY BE ASSEMBLED. CAREFULLY CHECK PARTS AND PACKING MATERIALS PRIOR TO ORDERING REPLACEMENTS.

Tools required: Screwdriver (not included)

NOTE: FOUR PEOPLE REQUIRED TO ASSEMBLE CANOPY

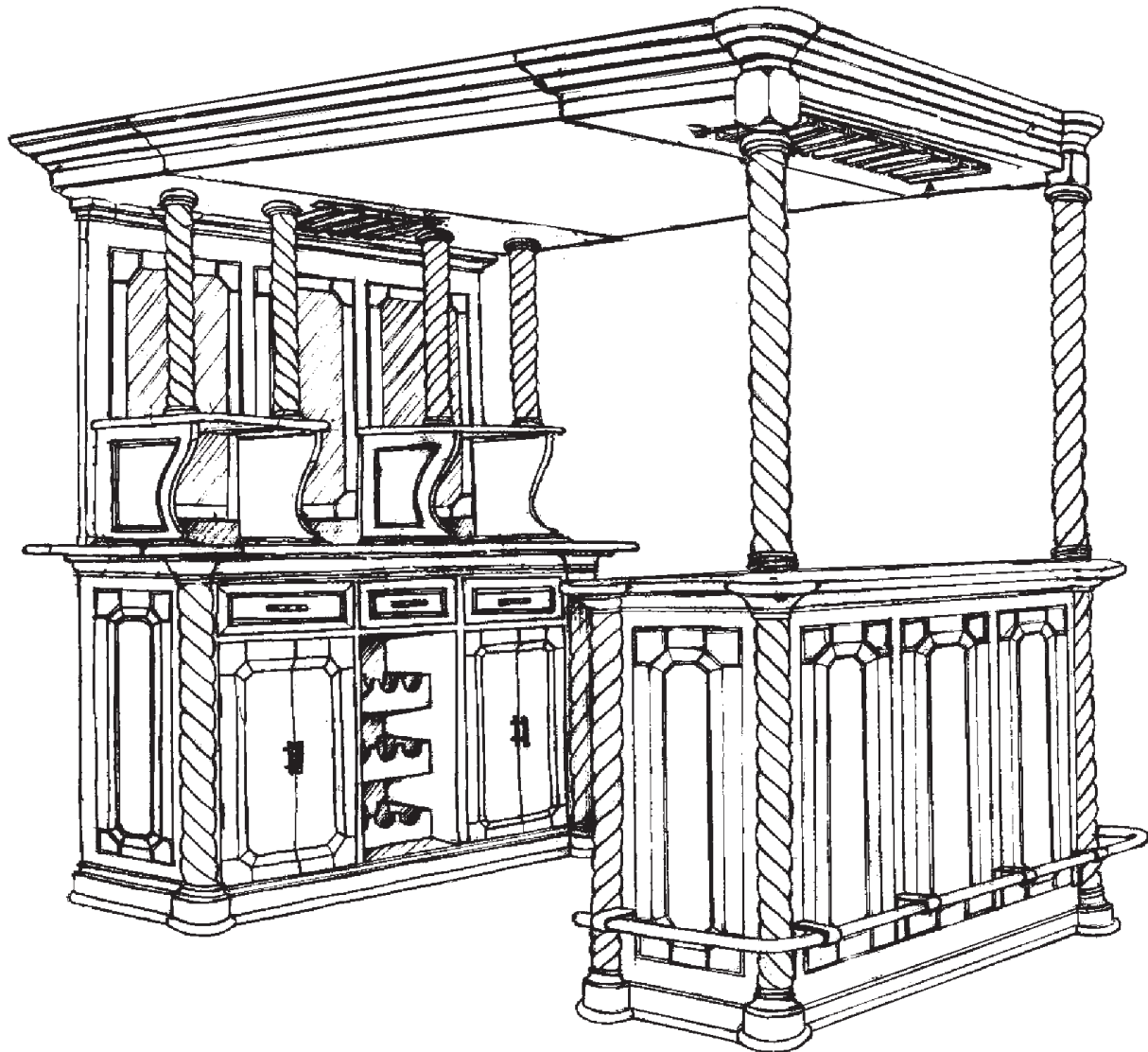

PARTS

- (A) CANOPY BACK
- (B) CANOPY CENTER
- (C) CANOPY FRONT
- (D) CANOPY OPTIONAL FRONT
- (E) SHORT POSTS (4)
- (F) LONG POSTS (2)
- (G) BACK GLASS RACK
- (H) FRONT GLASS RACK

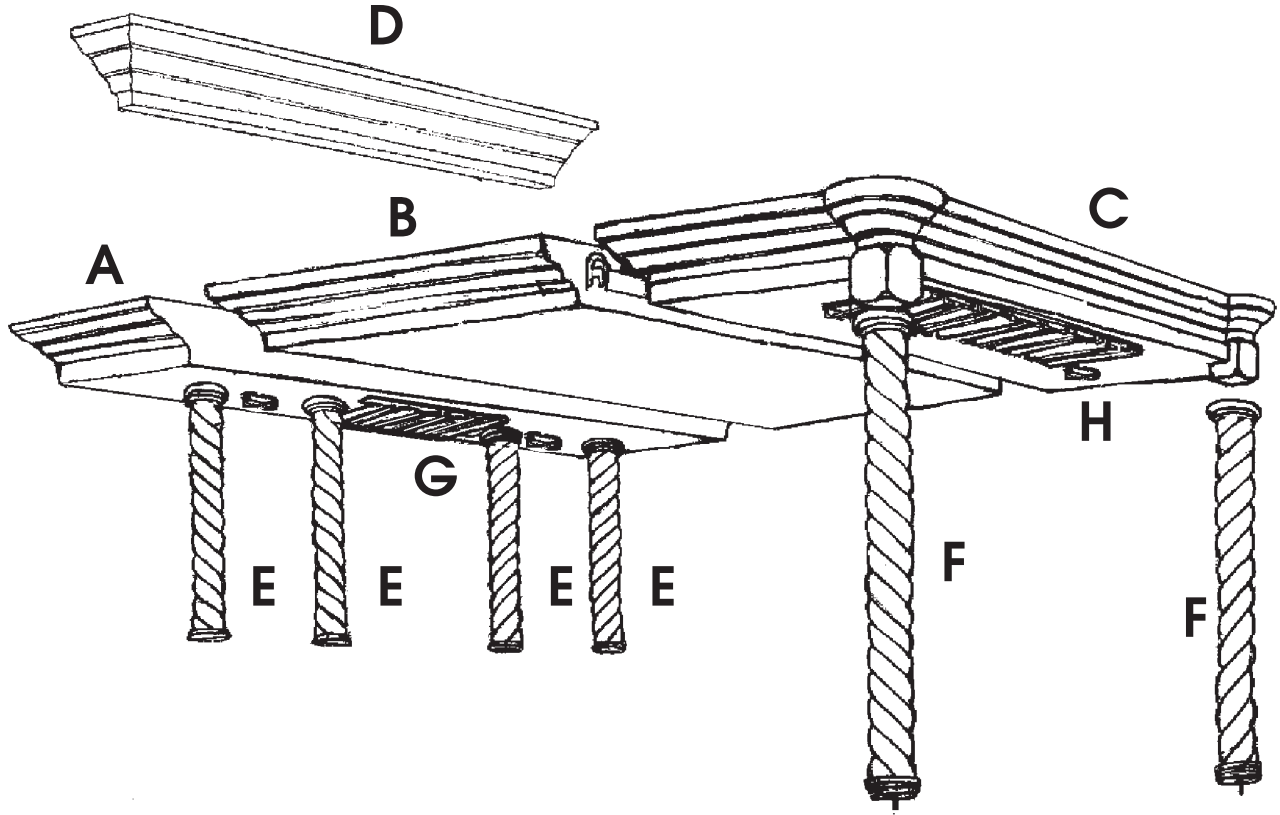

HARDWARE



I
(4 PIECES)



J
(8 PIECES)



K
(4 PIECES)



L
(2 PIECES)



K
(18 PIECES)



N
(16 PIECES)



O
(16 PIECES)

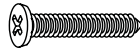

P
(16 PIECES)

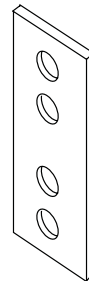

Q
(4 PIECES)

ASSEMBLY OPTION #1

STEP 1

(BAR BACK NOT INCLUDED)

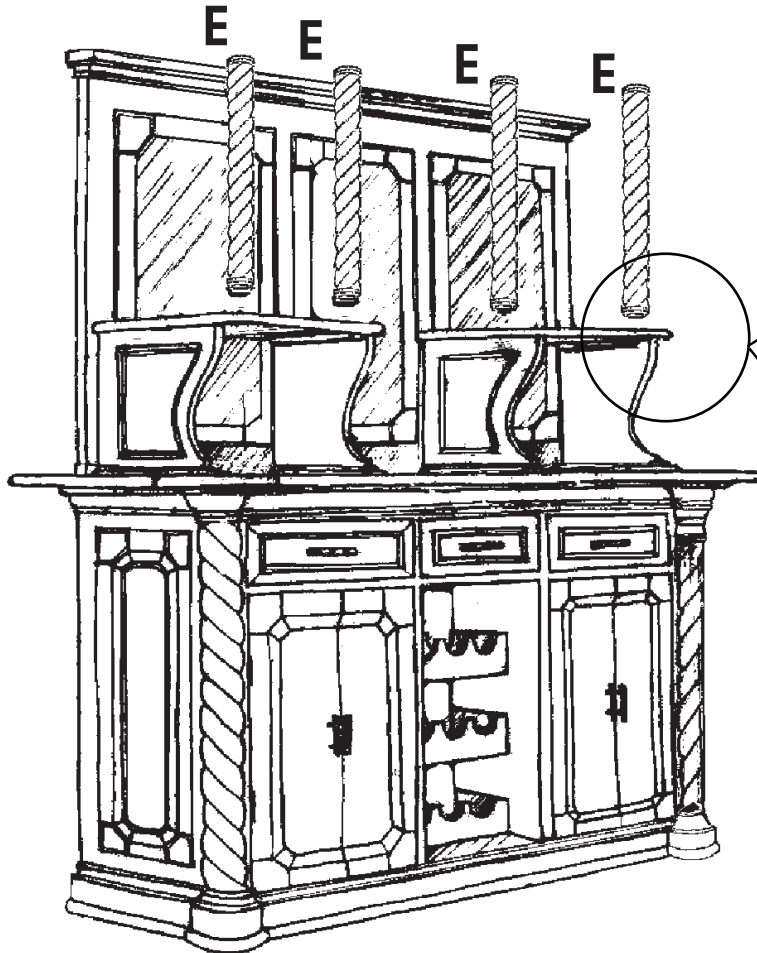
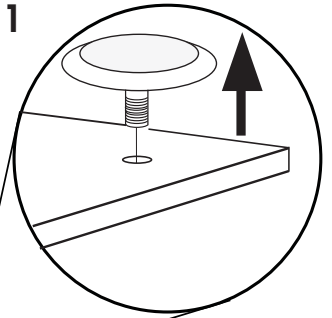
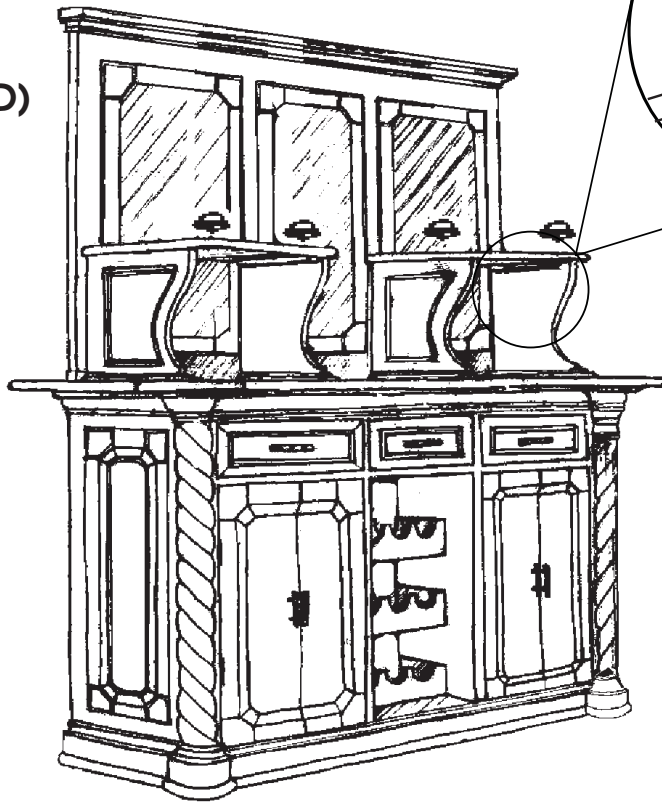

STEP 2

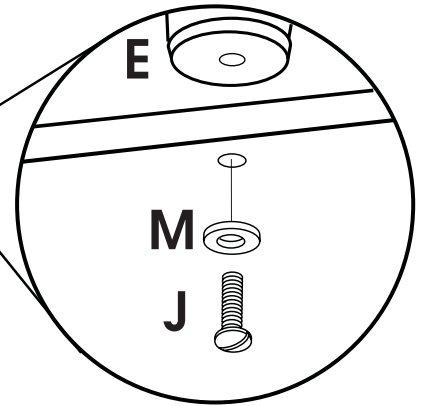

STEP 4

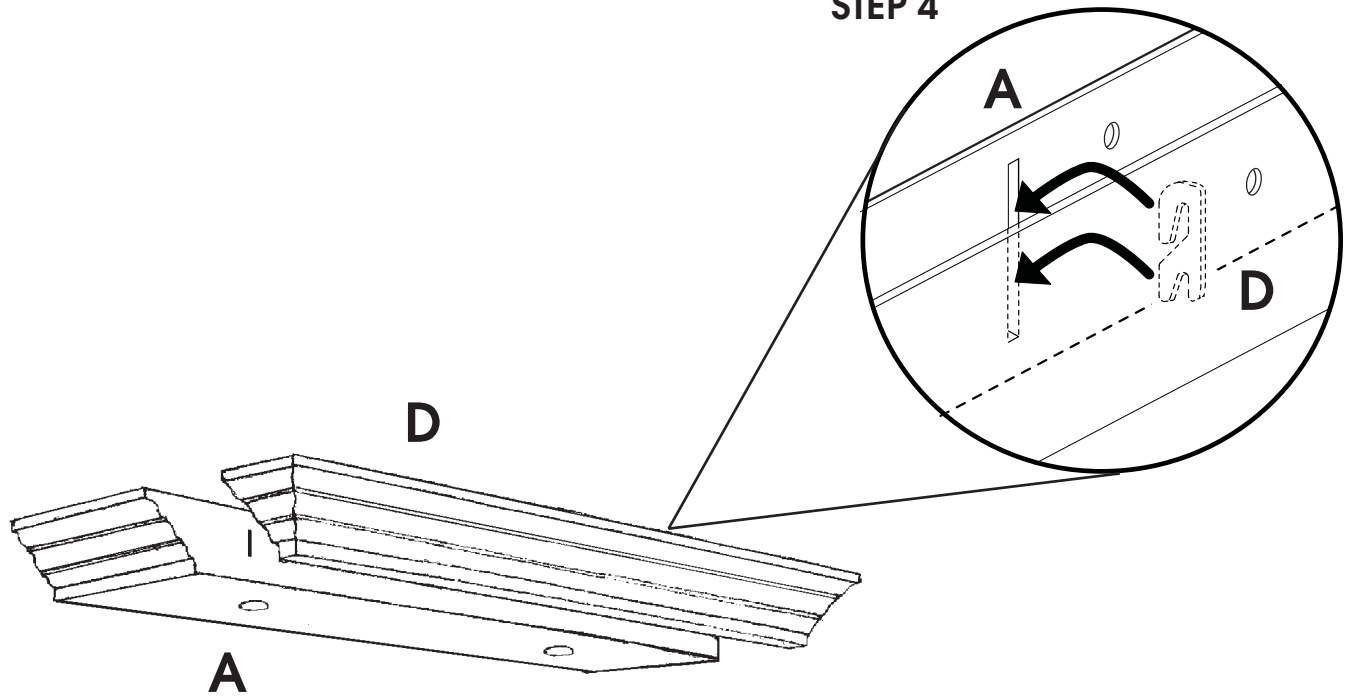

STEP 5

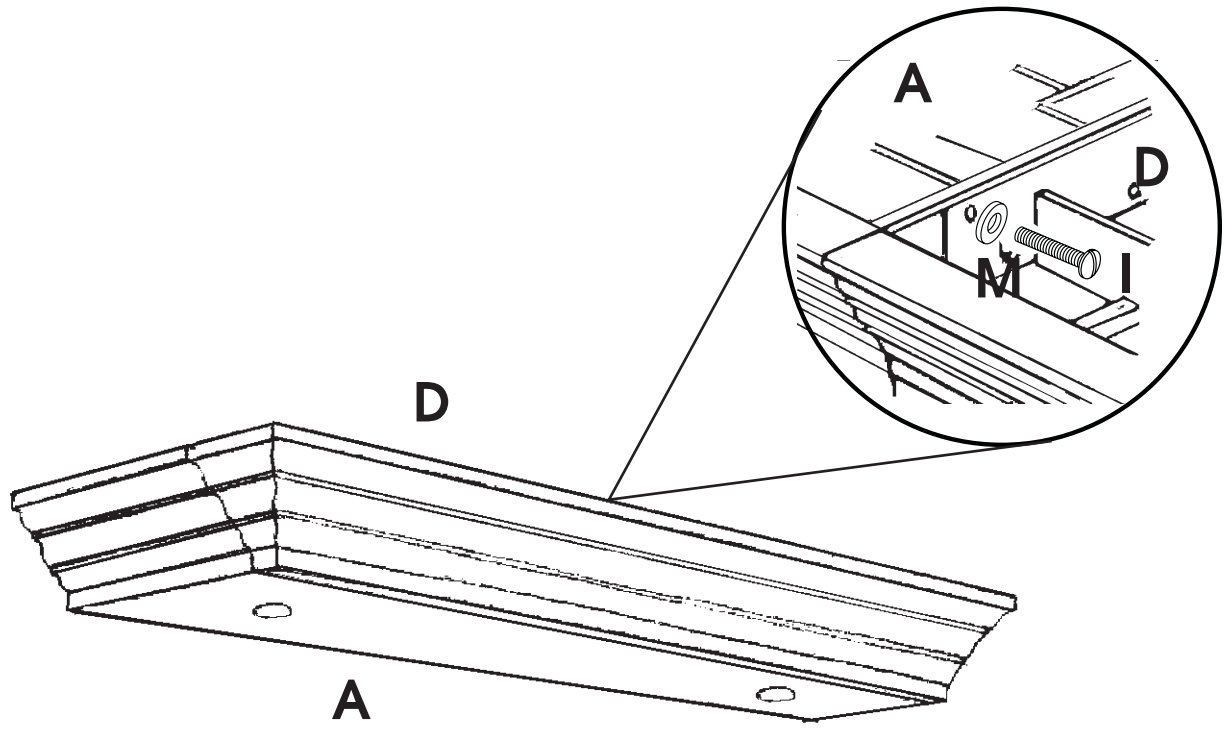

STEP 7

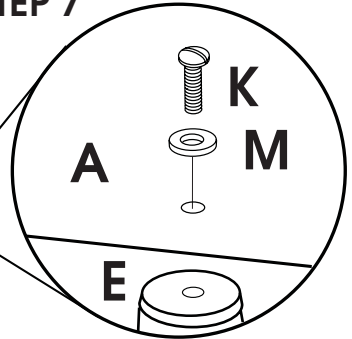

STEP 6

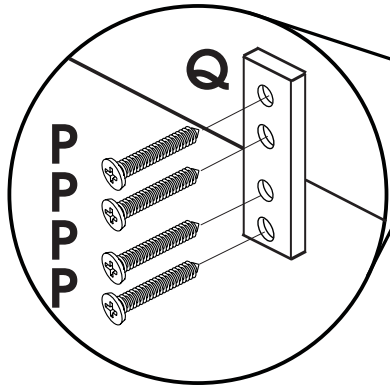

A

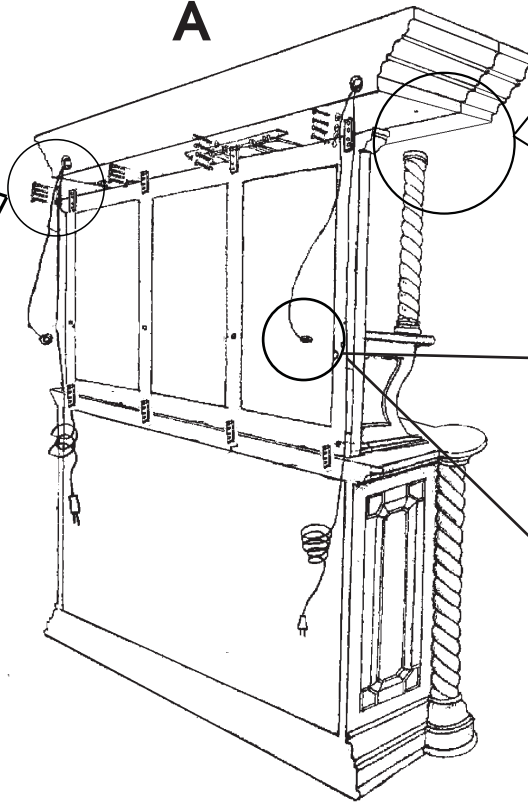

STEP 8

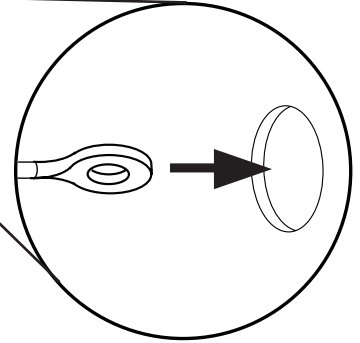

A

D

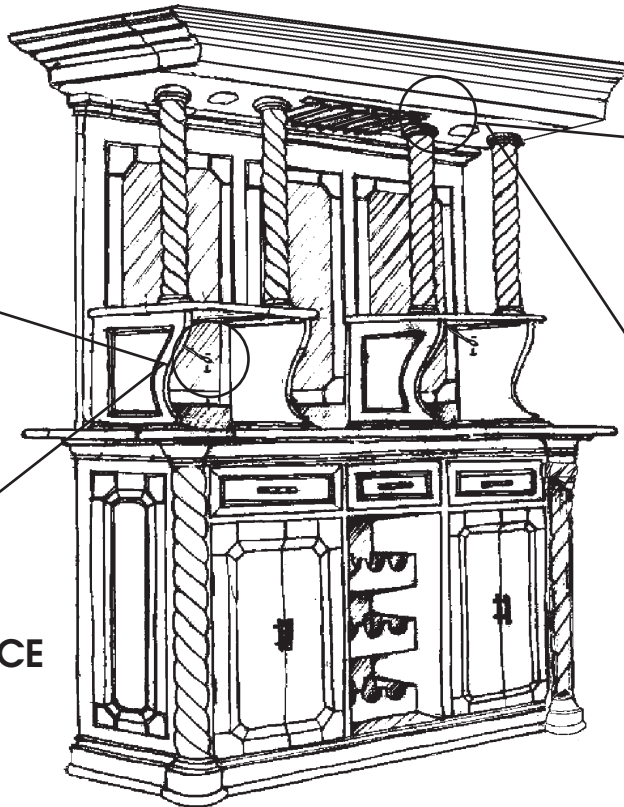

STEP 10

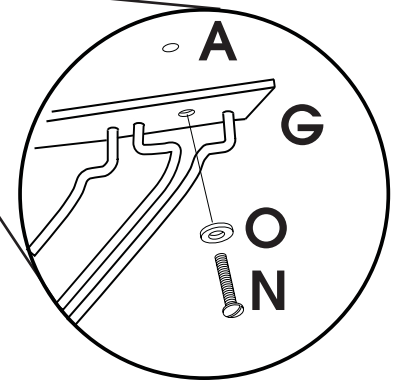

STEP 9

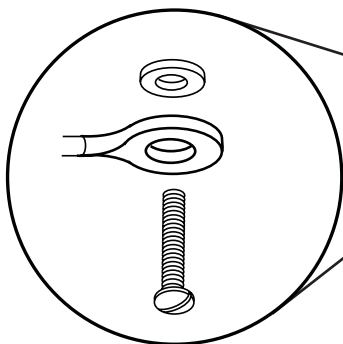

REMOVE AND REPLACE BOLT IN BACK BAR

ASSEMBLY OPTION #2

STEP 1

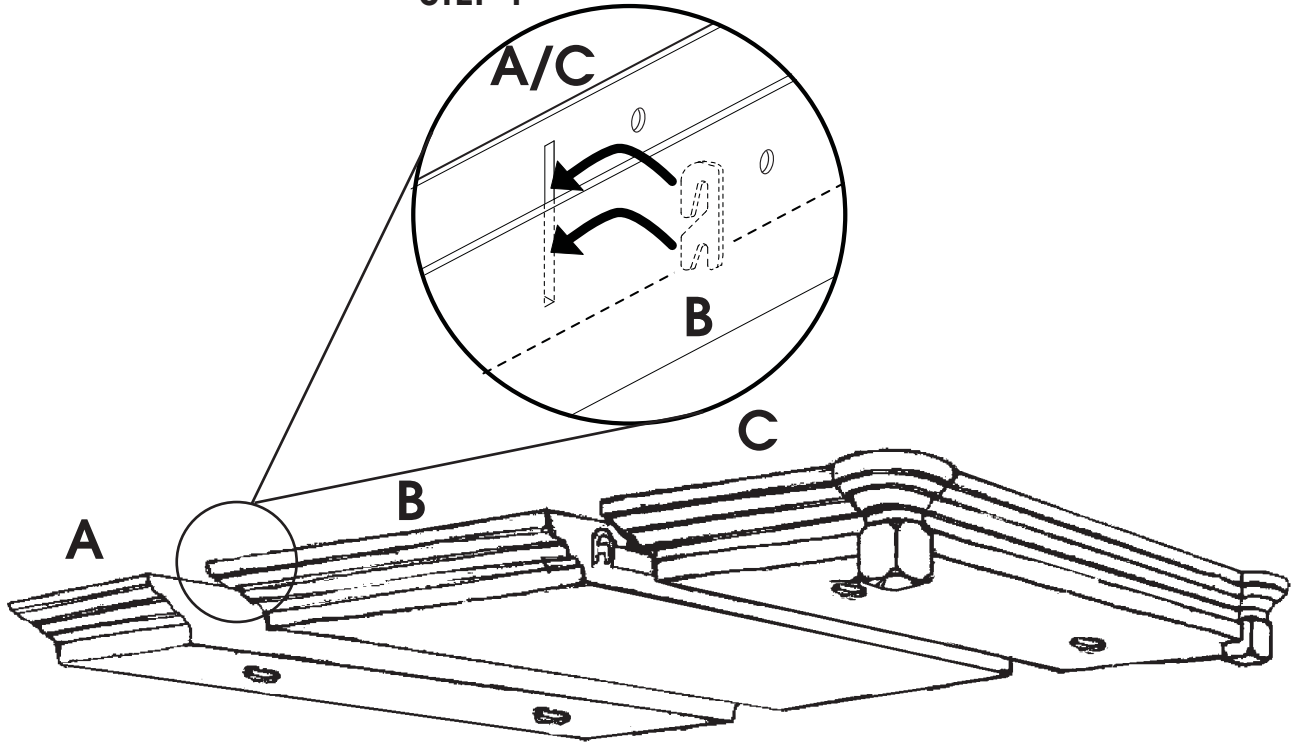

STEP 2

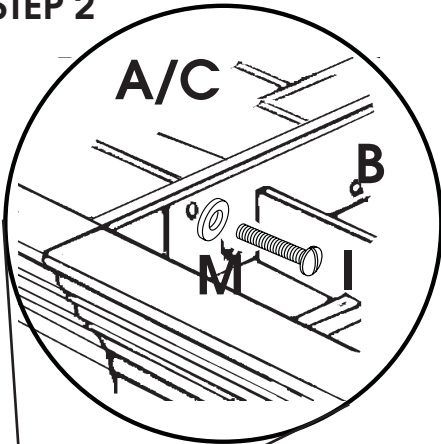

STEP 3

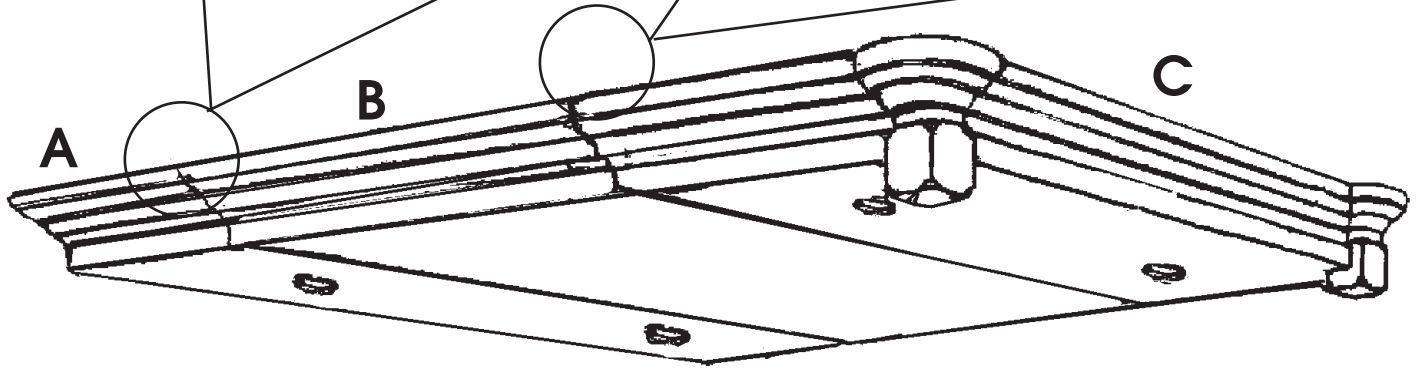
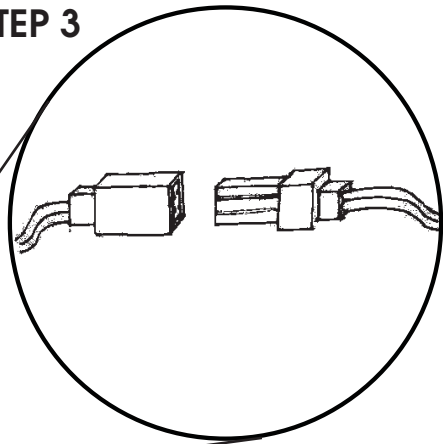

STEP 5

**(BAR FRONT AND BACK
NOT INCLUDED)**

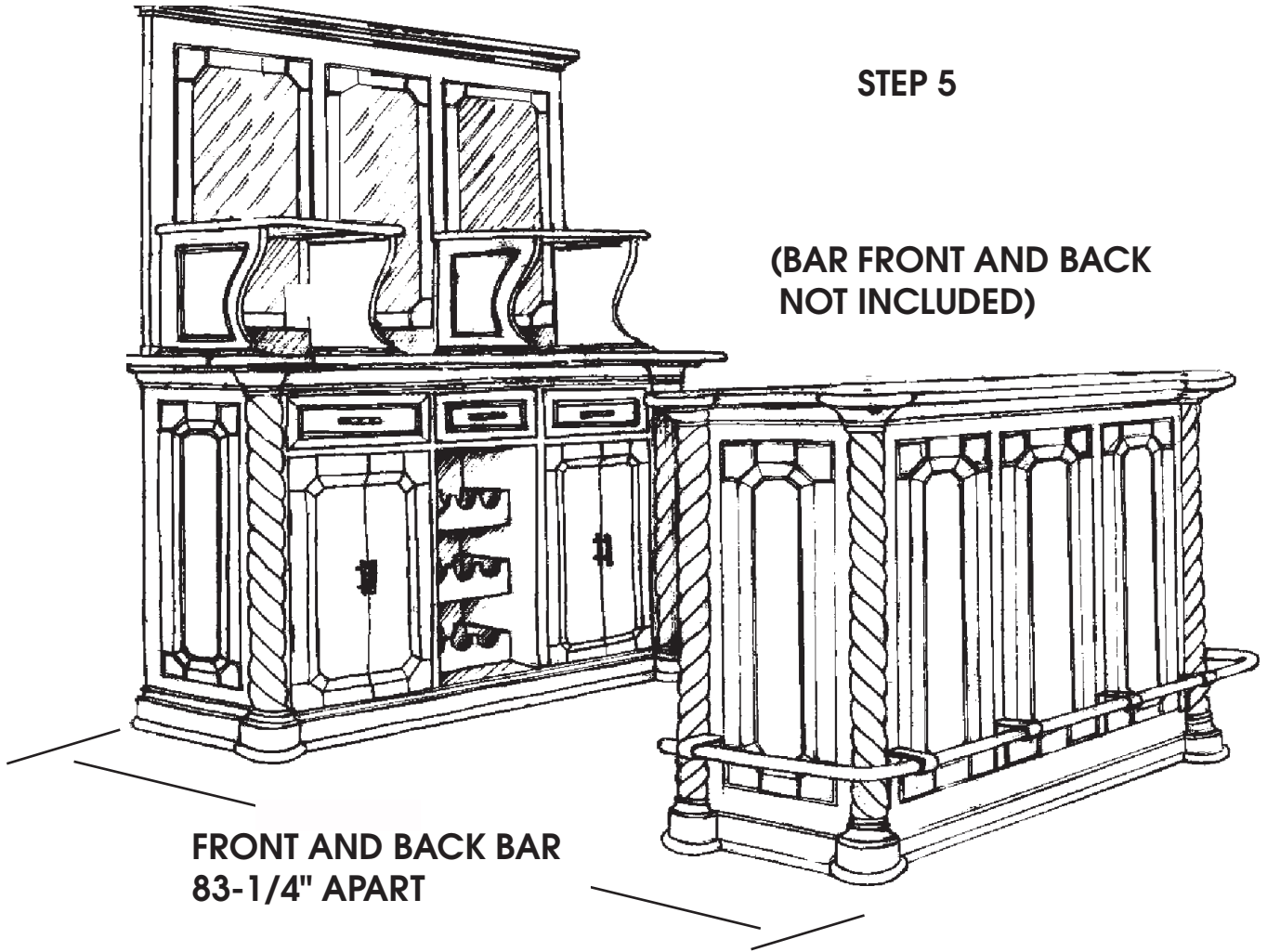

**FRONT AND BACK BAR
83-1/4" APART**

STEP 6

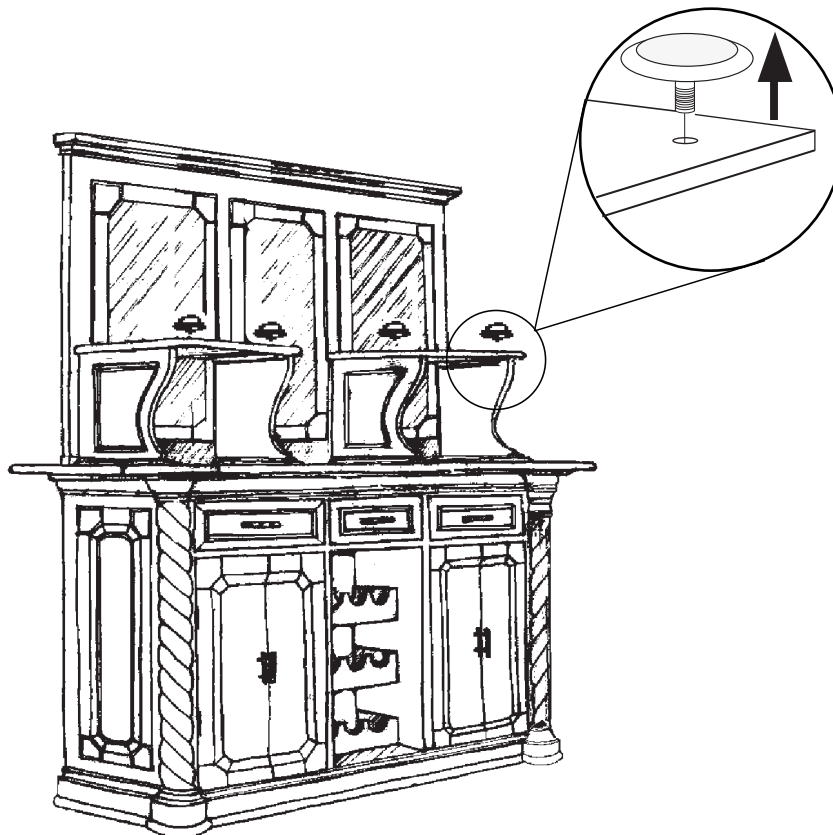

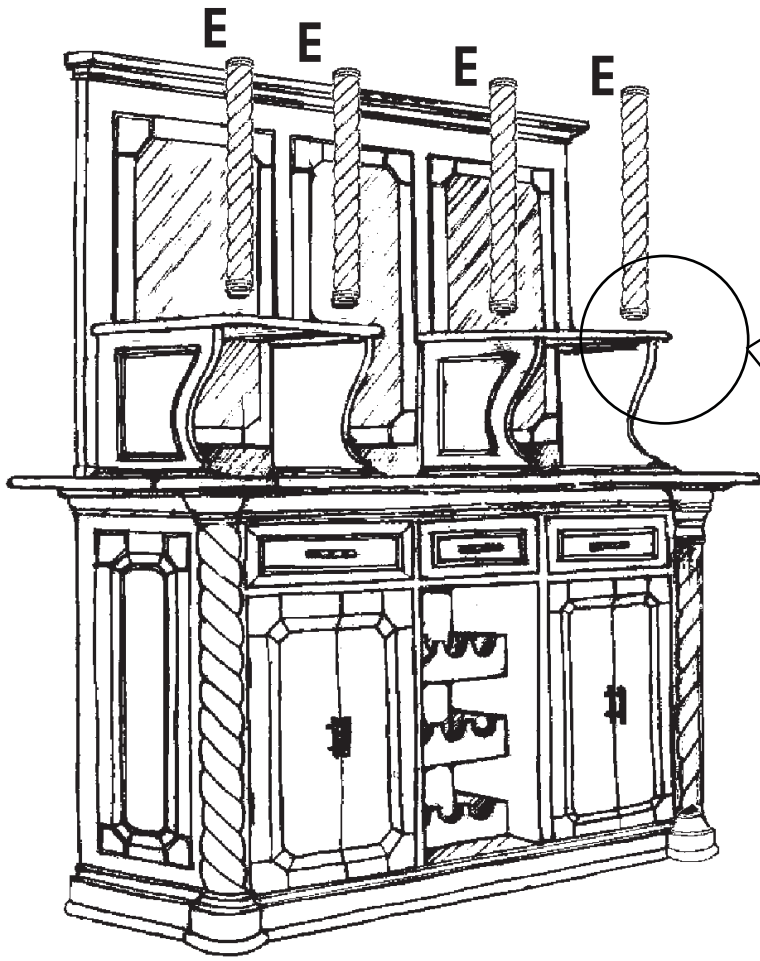

STEP 7

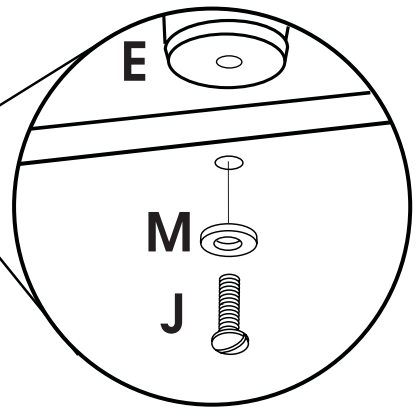

STEP 8

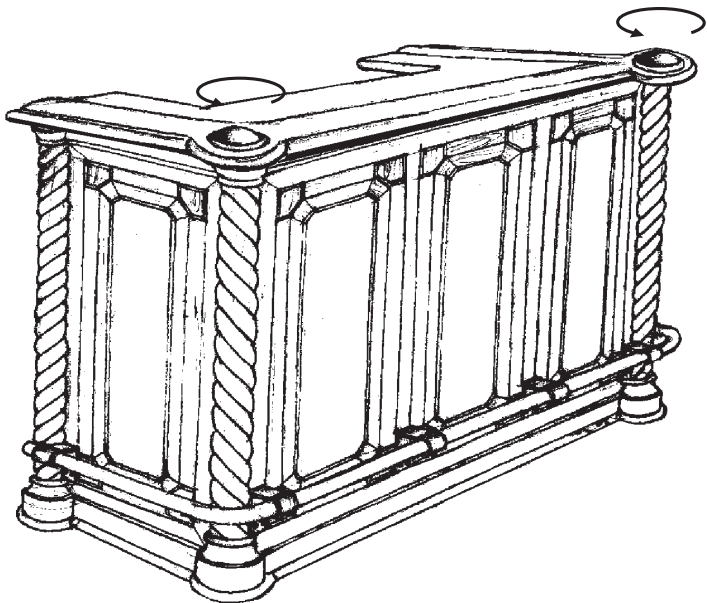

STEP 9

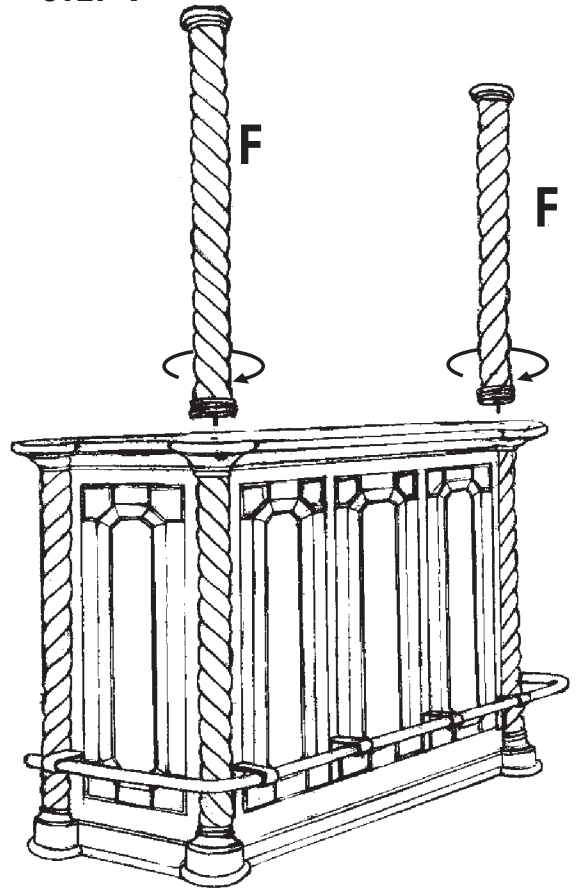

FOUR PEOPLE REQUIRED TO LIFT CANOPY

STEP 10

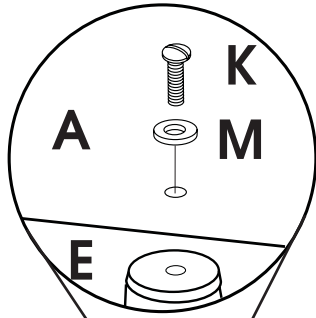

STEP 11

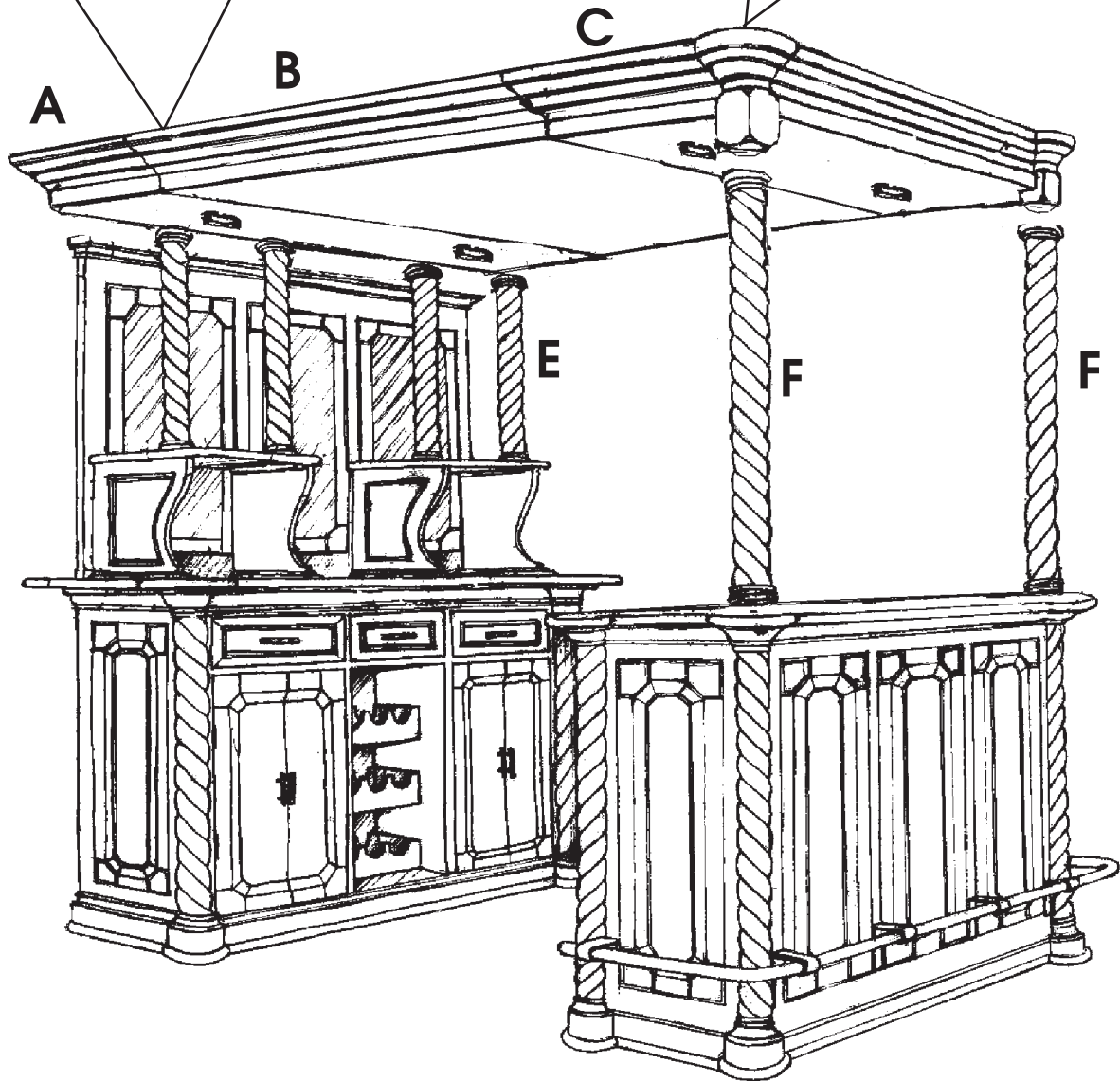
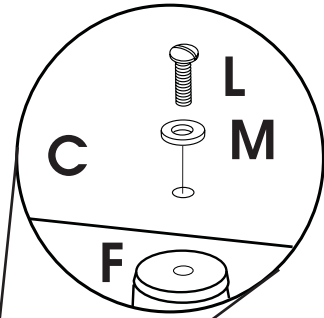

STEP 12

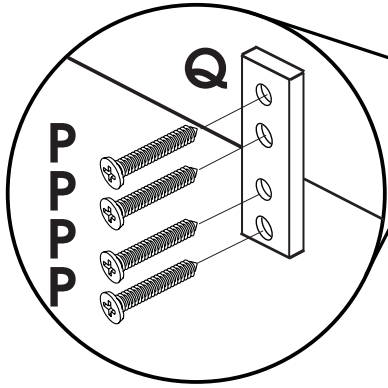

A

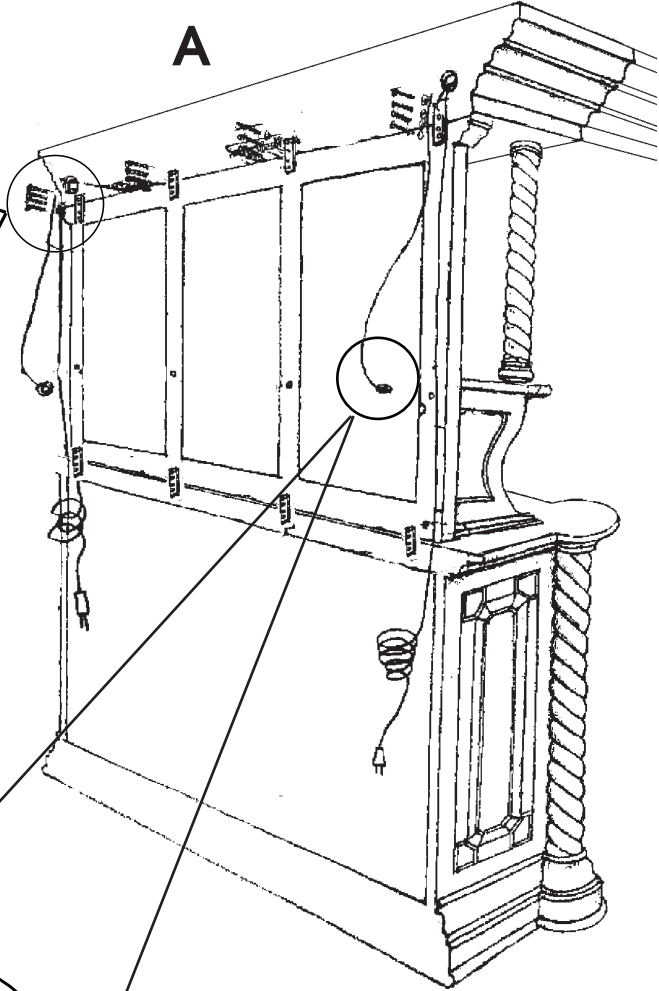

STEP 13

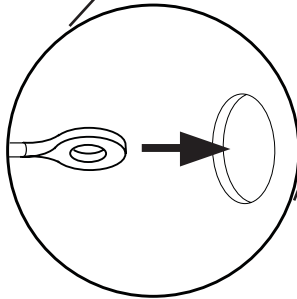

STEP 15

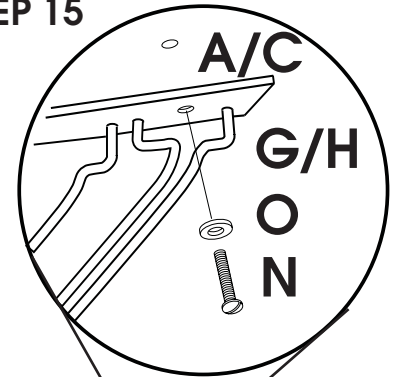

STEP 14

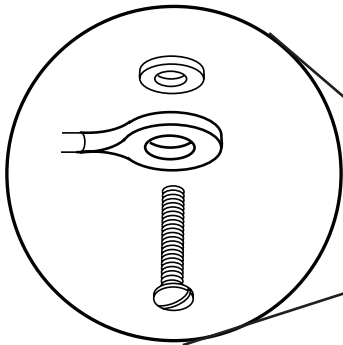

REMOVE AND REPLACE BOLT IN BACK BAR

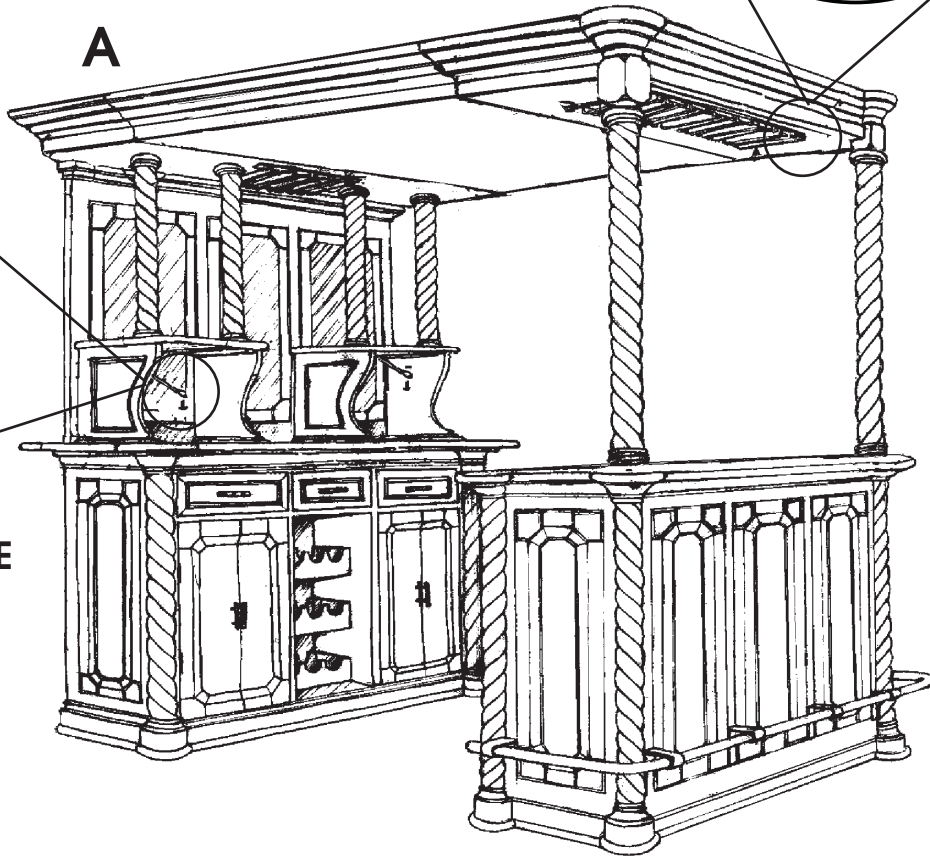

IF YOU HAVE A PROBLEM, WE WANT TO HAVE THE OPPORTUNITY TO MAKE IT RIGHT!

Should there be any missing or defective part(s),

FAX this form to (310) 841-0842

or call and ask for Customer Service at (800) 622-4456 or (310) 204-2224. Have your model number and part code letter handy.

MODEL NO. 570-485

© 2006 Powell

Part Letter	Description	Quantity

Name _____

Address _____

Daytime Phone () _____

Reason for Replacement _____

Place of Purchase _____