

PARTS

(A) LEFT SIDE PANEL	(N) BASKET
(B) RIGHT SIDE PANEL	(O) TRAY
(C) CROSS BRACES (2)	(P) TOP
(D) LARGE DOWELS (12)	(Q) LARGE WOOD SCREWS (4)
(E) FRONT DOOR	(R) DECORATIVE CROSS BRACES (3)
(F) BASE	(S) LEFT MAGAZINE RACK PANEL
(G) BACK DOOR	(T) RIGHT MAGAZINE RACK PANEL
(H) CAM-BOLTS (8)	(U) KNOBS (3)
(I) CAM-LOCKS (8)	(V) MAGNETS (2)
(J) COVERS (8)	(W) LONG MACHINE SCREWS (6)
(K) HANDLES (4)	(X) SMALL DOWELS (12)
(L) SHORT MACHINE SCREWS (8)	(Y) SMALL WOOD SCREWS (4)
(M) HINGE PINS (4)	

Thank you for purchasing this quality product. Be sure to check all packing material carefully for small parts which may have come loose inside the carton during shipment. Separate, identify, and count all parts and metal hardware. Compare with parts list to be sure all parts are present. If any part(s) are missing or damaged, phone, fax, or mail to our Customer Service Department. For efficient and speedy service, please indicate the model number and code letter of part(s) needed.

Tools required: Screwdriver (not included)

HARDWARE ILLUSTRATION

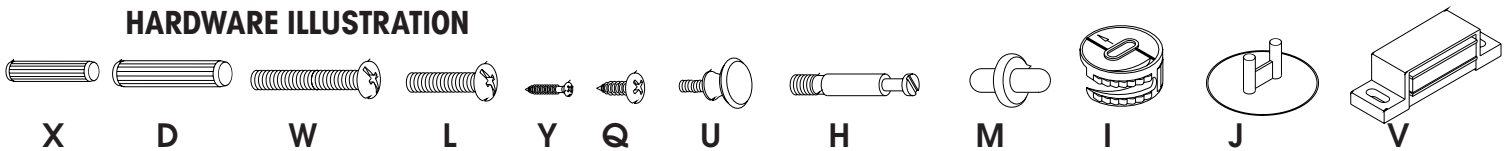

ATTENTION: SOME NUMBERED PARTS LISTED ON THE INSTRUCTION SHEET MAY NOT BE IN PARTS BAG AS THEY MAY ALREADY BE ASSEMBLED. CAREFULLY CHECK PARTS AND PACKING MATERIALS PRIOR TO ORDERING REPLACEMENTS.

IMPORTANT NOTE: Follow instructions listed below in the proper sequence as numbered to assure fast, easy and correct assembly.

- Note:** Upon opening, thoroughly clean all wood surfaces with furniture polish to remove dust and dirt that may have settled onto finish during shipment.
- Insert Small Wood Screws (Y) through ends of Magnets (V) and tighten into underside of Cross Braces (C). Insert Large Dowels (D) into ends of Cross Braces (C). Insert Large Dowels (D) extending from Cross Braces (C) into corresponding holes near top edge of Left and Right Side Panels (A,B). Glide on Side Panels (A,B) should face inward. (See ill. #1)
- Insert Short Machine Screws (L) through holes on back of Front Door (E) and tighten into Handles (K). (See ill. #2)
- Insert large Wood Screws (Q) through hoops in Basket (N) and tighten into corresponding holes on inside of Front Door (E). (See ill. #3)

#1

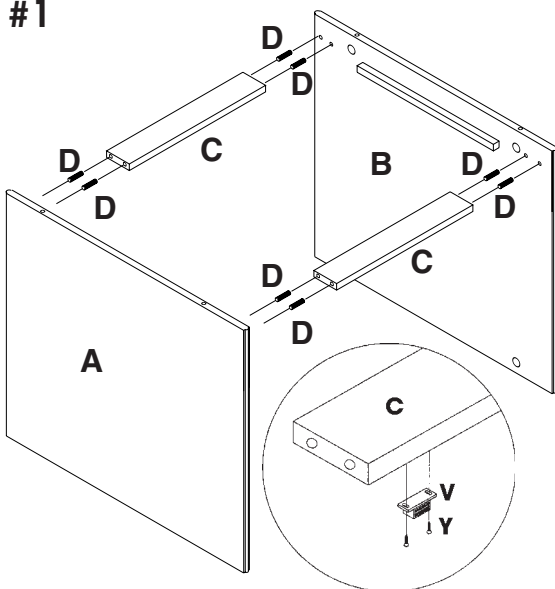

#2

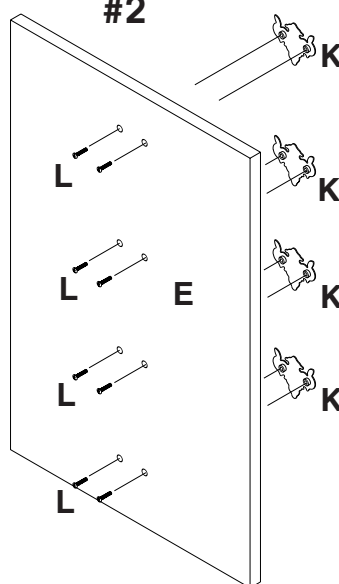

#3

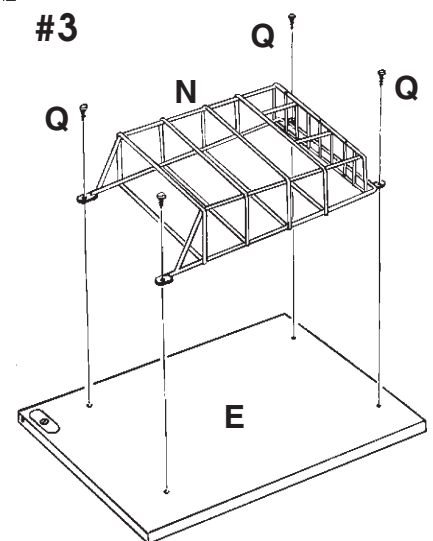

5. Tighten Cam-bolts (H) into threaded holes in Base (F). Insert Large Dowels (D) into center holes in Base (F). Insert Cam-locks (I) into large holes near bottom edge of Side Panels (A,B). Rotate Cam-locks (I) with a screwdriver so arrow points toward Cam-bolts (H). Note: Be sure that slot for screwdriver faces outward. Insert long end of Hinge Pins (M) into top and bottom corners of Doors (E,G). Align holes on bottom edge of Side Panels (A,B) with Cam-bolts (H) and Large Dowels (D) extending from Base (F) and insert Cam-bolts (H) and Large Dowels (D) into holes in bottom edge of Side Panels (A,B). Insert Hinge Pins (M) extending from bottom corner of Doors (E,G) into hole in Base (F). Lift Side Panels (A,B) slightly to allow insertion of Hinge Pins (M) extending from top corner of Doors (E,G) into hole in Cross Braces (C) and push Side Panels (A,B) and Cross Braces (C) downward until Side Panels (A,B) rests on Base (F). Rotate Cam-locks (I) clockwise to secure Side Panels (A,B) to Base (F). Push Covers (J) into Cam-locks (I). (See ill. #4)
6. Tighten Cam-bolts (H) into threaded holes in Top (P). Insert Cam-locks (I) into large holes near top edge of Side Panels (A,B). Rotate Cam-locks (I) with a screwdriver so arrow points toward Cam-bolts (H). (See ill. #4)
7. Rest Tray (O) onto Cross Braces (C) and glides attached to Side Panels (A,B). Finished side of Tray (O) should face upward. Tighten Knobs (U) into ends of Tray (O). Tighten Cam-bolts (H) into threaded holes and insert Large Dowels (D) into center holes in Top (P). Align Cam-bolts (H) and Large Dowels (D) extending from Top (P) with holes in top edge of Side Panels (A,B) and Press down on Top (P) until Top (P) rests on Side Panels (A,B). Rotate Cam-locks (I) clockwise to secure Top (P) to Side Panels (A,B). Push Covers (J) into Cam-locks (I). (See ill. #4)
8. Insert Small Dowels (X) into ends of Decorative Cross Braces (R). Insert Small Dowels (X) extending from Decorative Cross Braces (R) into corresponding holes of Left and Right Magazine Rack Panels (S,T). Insert Long Machine Screws (W) through inside of Left Side Panel (A), and tighten into holes on edge of Left and Right Magazine Rack Panels (S,T). Insert Long Machine Screws (W) through bottom of Base (F), and tighten into holes on end of Left and Right Magazine Rack Panels (S,T). (See ill. #5)
9. Your furniture has been handcrafted and skillfully finished by fine craftsmen. Rich, deep antique finishes have been applied which require very little polish. However, should you desire a shinier finish, simply use any good grade of furniture polish, rubbing the finish lightly as it is being applied. Allow to dry and buff lightly with a soft cloth.

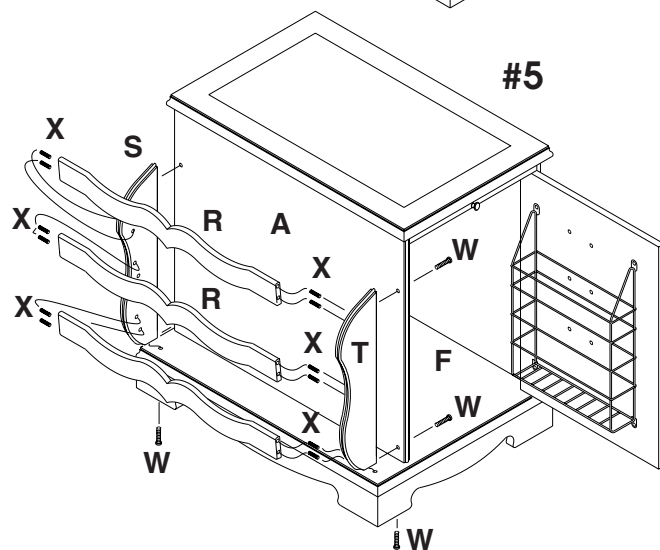
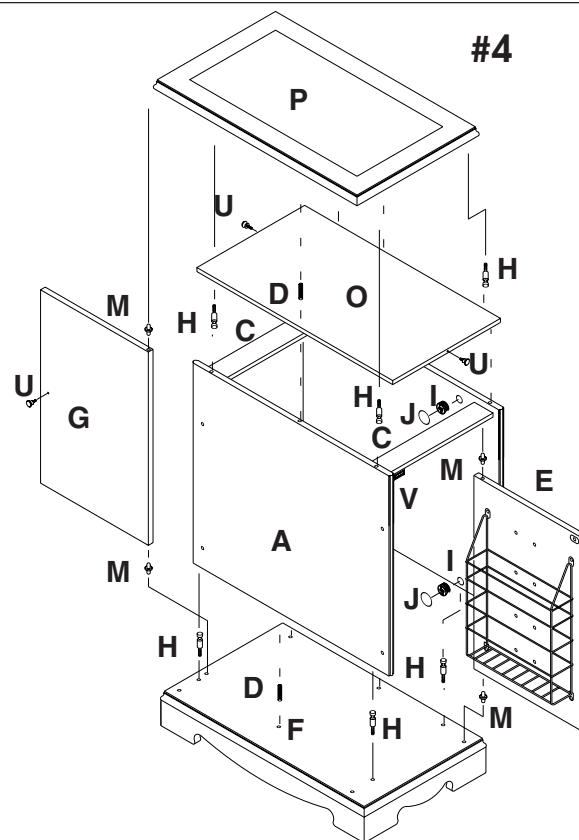

IF YOU HAVE A PROBLEM, WE WANT TO HAVE THE OPPORTUNITY TO MAKE IT RIGHT!

Should there be any missing or defective part(s),

FAX this form to (310) 841-0842

or call Customer Service at (800) 622-4456 or (310) 204-2224

Have your model number and part code letter handy.

MODEL NO. 449H "HEIRLOOM CHERRY"
469H "NOSTALGIC OAK"

© 1997 Powell

Part Letter	Description	Quantity

Name _____
Address _____
Daytime Phone () _____
Reason for Replacement _____
Place of Purchase _____