

U.S. PATENT NO. D397,886  
FOREIGN PATENTS PENDING

Made in China

### PARTS

(A) VANITY TOP	(K) BENCH TOP	(T) CAM-LOCKS (8)
(B) LAP DRAWER	(L) DRAWER RING PADS	(U) CAM-BOLTS (8)
(C) LONG LEGS (2)	(M) KNOBS (6)	(V) WASHERS (24)
(D) BASE	(N) DOOR PULL	(W) DOWELS (4)
(E) SHORT LEGS (4)	(O) BACK PLATES (7)	(X) WOOD PLUGS (2)
(F) MIRROR	(P) LONG SCREWS (20)	(Y) LOCK WASHERS (22)
(G) MIRROR POSTS (2)	(Q) MEDIUM SCREWS (4)	(Z) DRAWER 8 SQUARES
(H) CROSS BRACE	(R) SHORT SCREWS (2)	(Aa) DRAWER 4 SQUARES
(I) MEDIUM LEGS (4)	(S) MIRROR HANDLES (2)	(Bb) DRAWERS OPEN (3)
(J) CABINET		

Thank you for purchasing this quality product. Be sure to check all packing material carefully for small parts which may have come loose inside the carton during shipment. Separate, identify, and count all parts and metal hardware. Compare with parts list to be sure all parts are present. If any part(s) are missing or damaged, phone, fax, or mail to our Customer Service Department. For efficient and speedy service, please indicate the model number and code letter of part(s) needed.

Tools required: Screwdriver  
(not included)

### HARDWARE ILLUSTRATION

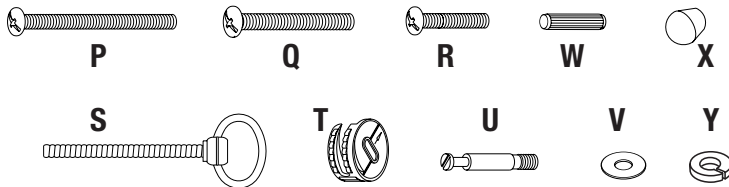

ATTENTION: SOME NUMBERED PARTS LISTED ON THE INSTRUCTION SHEET MAY NOT BE IN PARTS BAG AS THEY MAY ALREADY BE ASSEMBLED. CAREFULLY CHECK PARTS AND PACKING MATERIALS PRIOR TO ORDERING REPLACEMENTS.

**IMPORTANT NOTE:** Follow instructions listed below in the proper sequence as numbered to assure fast, easy and correct assembly.

- Note:** Upon opening, thoroughly clean all wood surfaces with furniture polish to remove dust and dirt that may have settled onto finish during shipment.
- Place parts on a soft cloth. Place Vanity Top (A) upside down. Slide Lap Drawer (B) outward. Insert Long Screws (P) through Lock Washers (Y), Washers (V), corners of Vanity Top (A), and tighten into Long Legs (C). Slide Lap Drawer (B) into place. (See ill. #1)
- Remove Cabinet Drawers (L, Z, Aa, Bb) from Cabinet (J). Tighten Cam-bolts (U) into underside of Vanity Top (A). Insert Cam-bolts (U) extending from Vanity Top (A) into top of Cabinet (J). Insert Cam-locks (T) into large holes in Cabinet (J) with slot for screwdriver facing outward. (See ill. #1)

- Tighten Cam-bolts (U) into top of Base (D). Insert Cam-bolts (U) extending from Base (D) into bottom of Cabinet (J). Insert Cam-locks (T) into large holes in Cabinet (J) with slot for screwdriver facing outward. Rotate all Cam-locks (T) in Cabinet (J) clockwise to secure Cabinet (J) to Vanity Top (A) and Base (D). Insert Short Screws (R) through Washers (V) skirt of Vanity Top (A) and tighten into side of Cabinet (J). (See ill. #1 & 2)

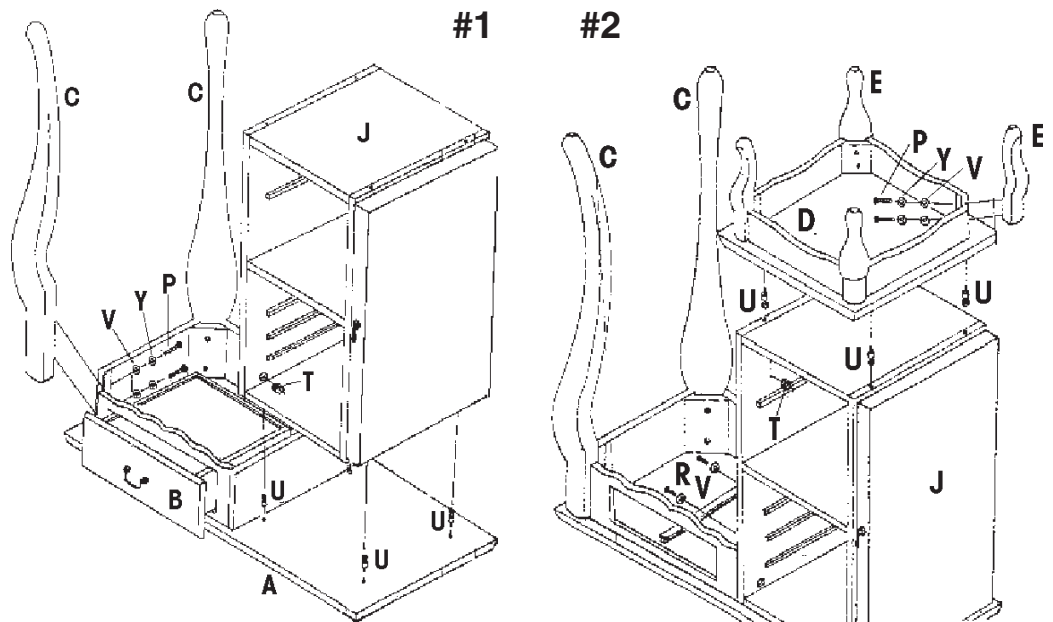

5. Insert Long Screws (P) through Lock Washers (Y), Washers (V), corners of Base (D), and tighten into Short Legs (E). Stand vanity upright. (See ill. #2)
6. Insert Dowels (W) into bottom and side holes of Mirror Posts (G). Insert Dowels (W) extending from side Mirror Posts (G) into Cross Brace (H). Insert Medium Screws (Q) through bottom of Mirror Post (G) and tighten into Cross Brace (H). Insert Wood Plugs (X) into holes in Mirror Posts (G). Align dowels (W) extending from bottom of Mirror Posts (G) with holes on back edge of Vanity Top (A). Insert Medium Screws (Q) through Lock Washers (Y), Washers (V), back edge of Vanity Top (A) and tighten into Cross Brace (H). (See ill. #3)
7. While holding Mirror (F) in position between Mirror Posts (G) insert Mirror Handles (S) through Mirror Posts (G) and tighten into sides of Mirror (F). (See ill. #3)
8. Insert threads of Knobs (M), through Back Plates (O) and tighten into Cabinet Drawers (L, Z, Aa, Bb). Insert threads of Door Pull (N) through Back Plate (O) and tighten into door of Cabinet (J). Slide Cabinet Drawers (L, Z, Aa, Bb) into Cabinet (J). (See ill. #4)
9. Place Bench Top (K) upside down. Insert Long Screws (P) through Lock Washers (Y), Washers (V), corners of Bench Top (K), and tighten into Medium Legs (I). (See ill. #5)

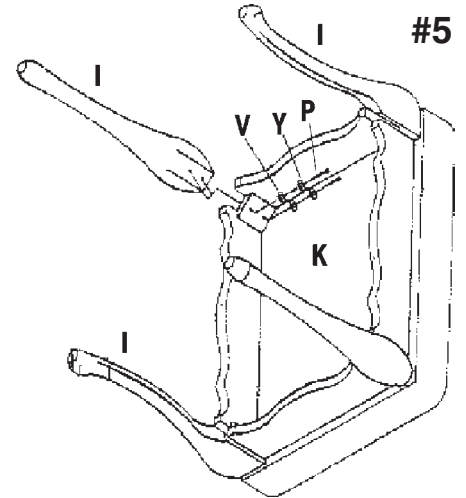
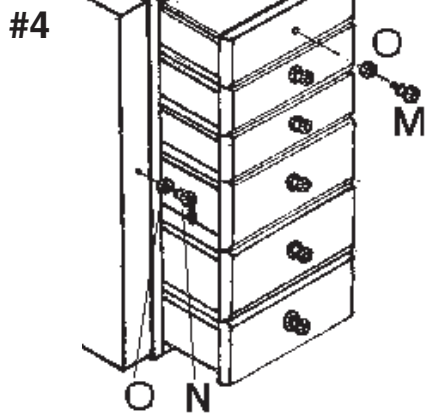
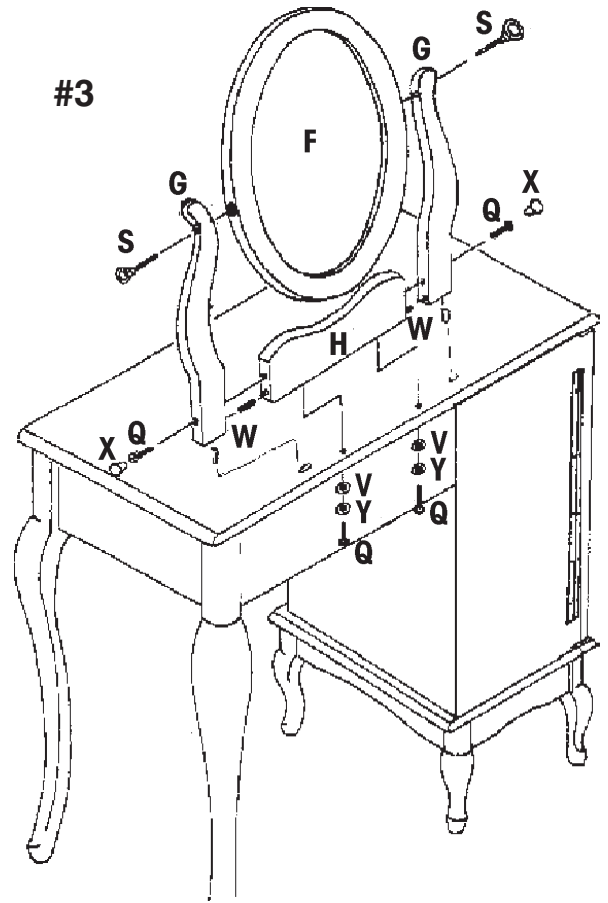

10. Your furniture has been handcrafted and skillfully finished by fine craftsmen. Rich, deep antique finishes have been applied which require very little polish. However, should you desire a shinier finish, simply use any good grade of furniture polish, rubbing the finish lightly as it is being applied. Allow to dry and buff lightly with a soft cloth.

**IF YOU HAVE A PROBLEM, WE WANT TO HAVE THE OPPORTUNITY TO MAKE IT RIGHT!**

Should there be any missing or defective part(s),  
**FAX this form to (310) 841-0842**  
 or call and ask for Customer Service at (800) 622-4456 or (310) 204-2224. Have your model number and part code letter handy.

**MODEL NO. 402 "Heirloom Cherry"**  
**407 "Nostalgic Oak"**  
 © 1997 Powell

Part Letter	Description	Quantity

Name \_\_\_\_\_  
 Address \_\_\_\_\_  
 Daytime Phone (     ) \_\_\_\_\_  
 Reason for Replacement \_\_\_\_\_  
 Place of Purchase \_\_\_\_\_