



ASSEMBLY INSTRUCTIONS (WF)

MODEL NO. 365-257

Made in Vietnam

Thank you for purchasing this quality product. Be sure to check all packing material carefully for small parts which may have come loose inside the carton during shipment. Separate, identify, and count all parts and metal hardware. Compare with parts list and hardware illustrations to be sure all parts are present. If any part(s) are missing or damaged, phone, fax, or mail to our Customer Service Department. For efficient and speedy service, please indicate the model number and code letter of part(s) needed.

ATTENTION: SOME LETTERED PARTS LISTED ON THE INSTRUCTION SHEET MAY NOT BE IN PARTS BAG AS THEY MAY ALREADY BE ASSEMBLED. CAREFULLY CHECK PARTS AND PACKING MATERIALS PRIOR TO ORDERING REPLACEMENTS.

Tools Required : Allen key (included)

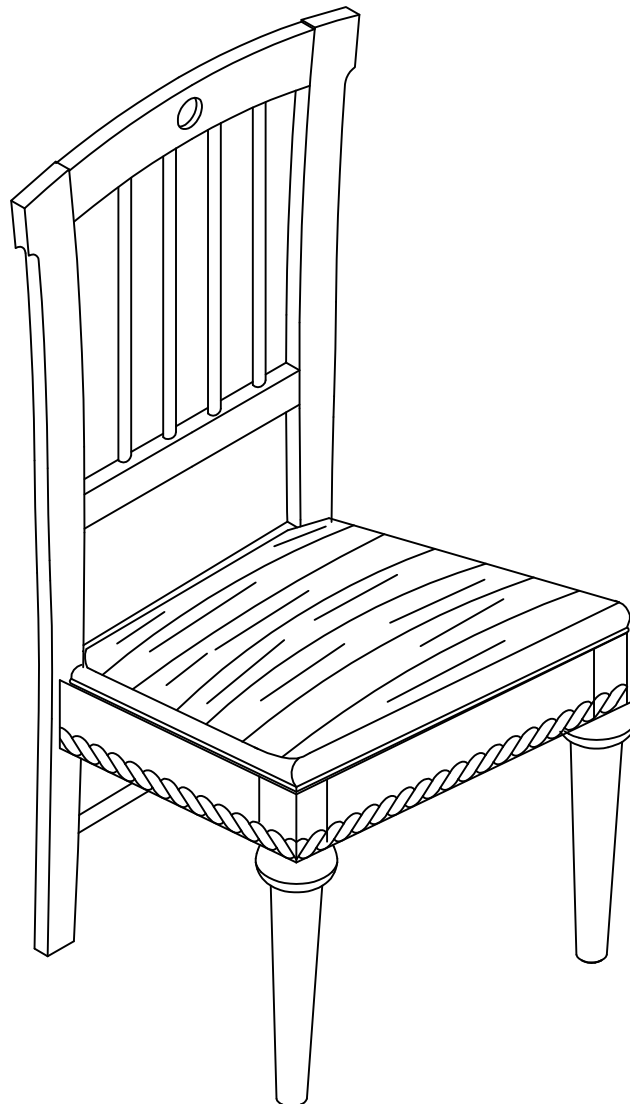

PARTS

(A) BACK ASSEMBLY(1)

(B) FRONT LEGS (2)

(C) CUSHION (1)

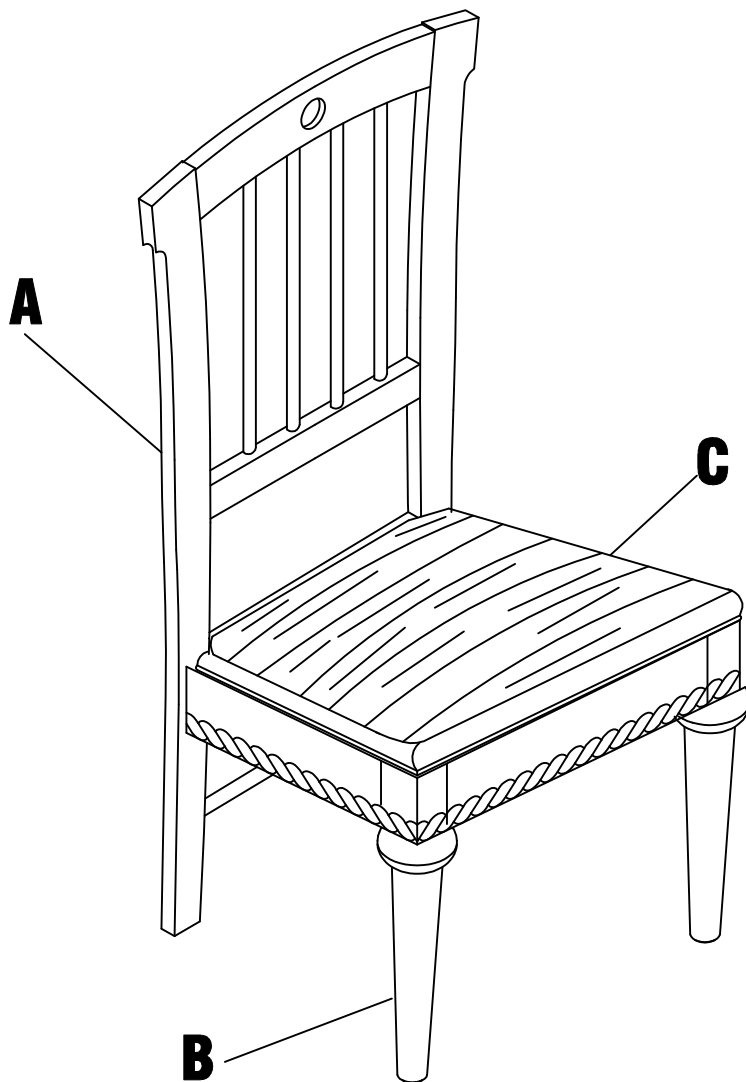

HARDWARE

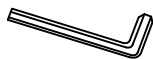

D

(1 PIECES)

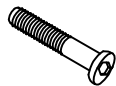

E

(4 PIECES)



F

(10 PIECES)



G

(10 PIECES)

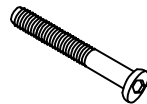

H

(4 PIECES)



I

(2 PIECES)

STEP 1

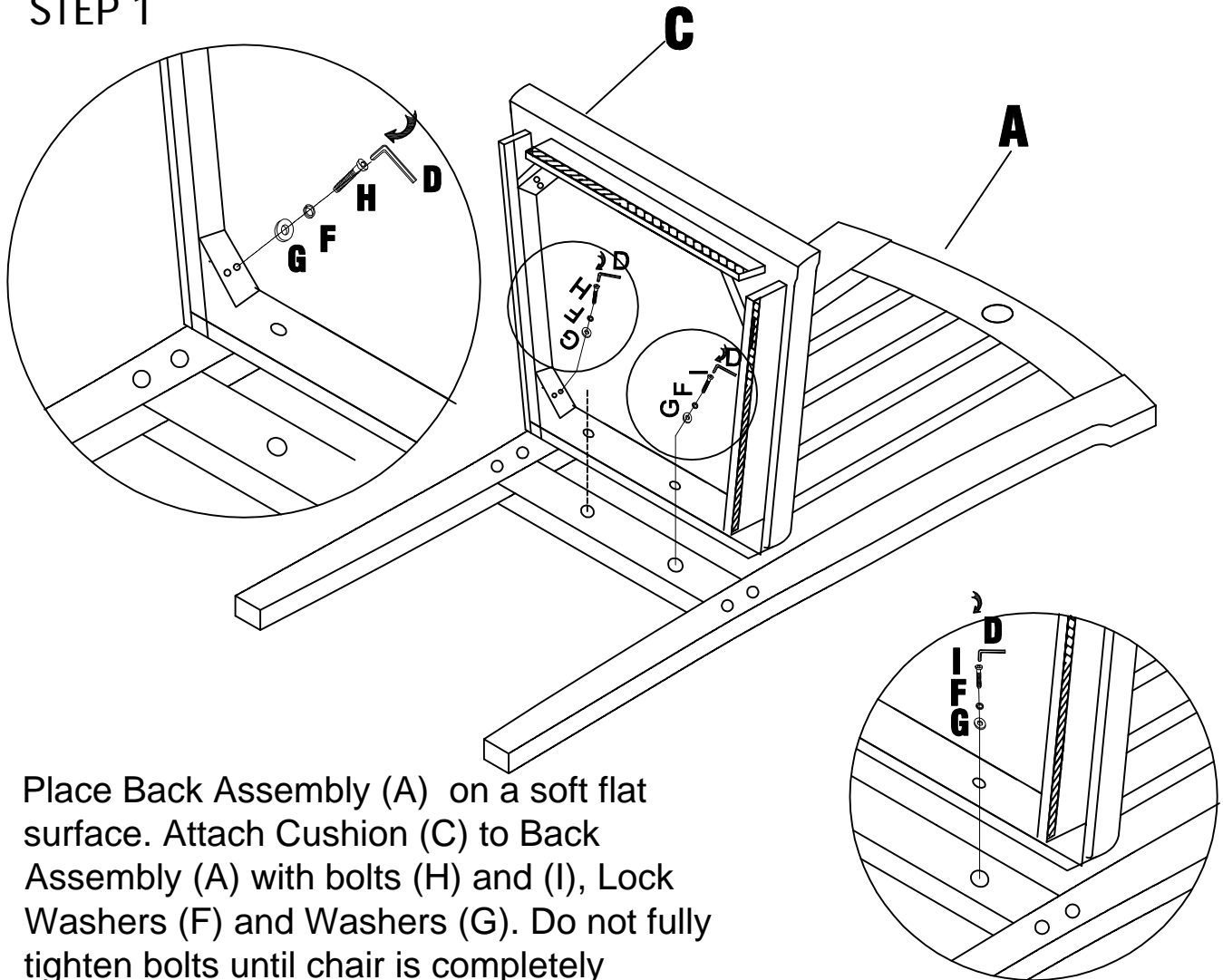

Place Back Assembly (A) on a soft flat surface. Attach Cushion (C) to Back Assembly (A) with bolts (H) and (I), Lock Washers (F) and Washers (G). Do not fully tighten bolts until chair is completely assembled

STEP 2

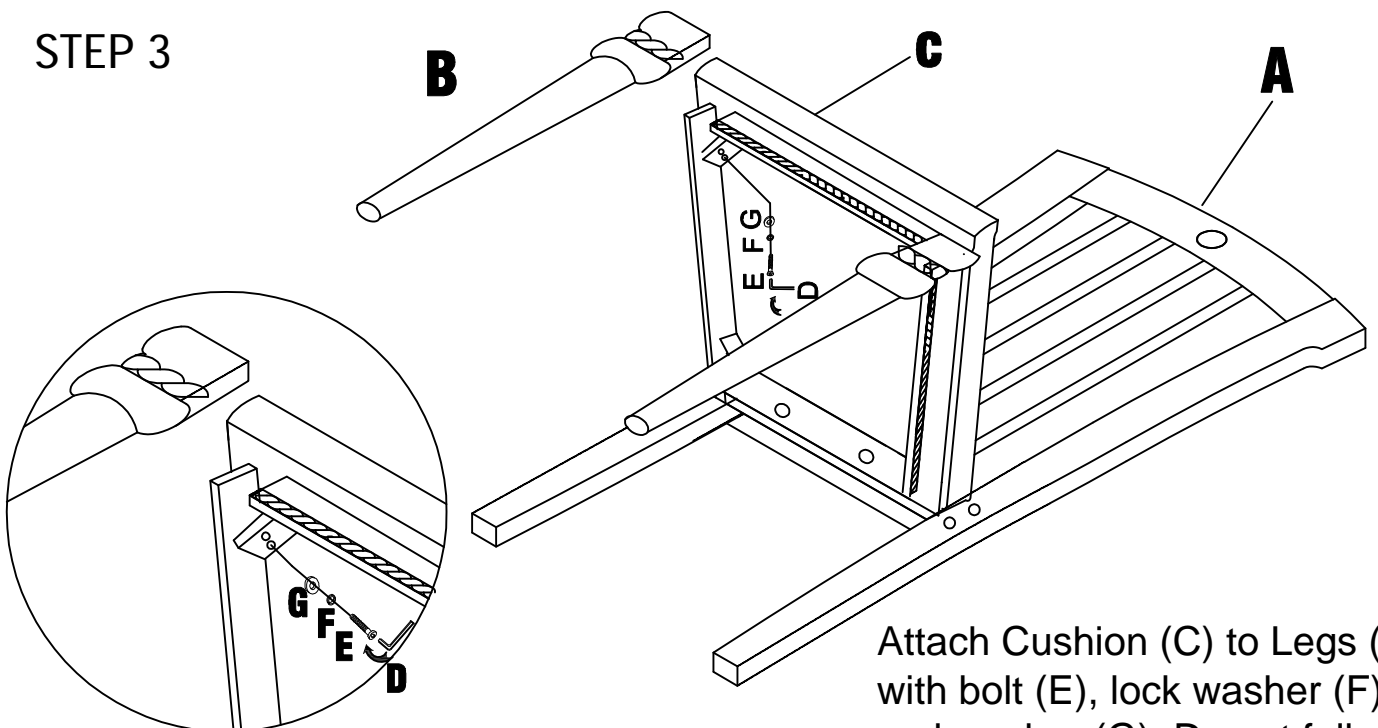

Attach Cushion (C) to Legs (B) with bolt (E), lock washer (F) and washer (G). Do not fully tighten all bolts until chair is completely assembled

STEP 4

Stand assembled chair upright on a hard flat surface and adjust legs until all four are level, then fully tighten all screws/bolts.

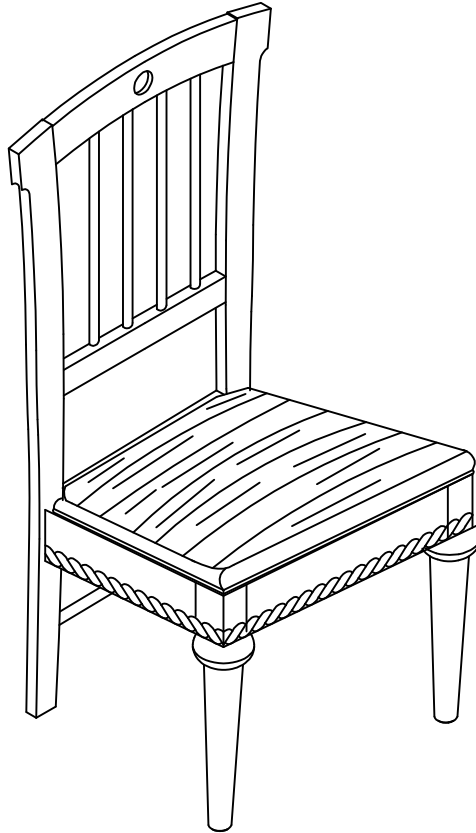

IF YOU HAVE A PROBLEM, WE WANT TO HAVE THE OPPORTUNITY TO MAKE IT RIGHT!

Should there be any missing or defective part(s)

MODEL NO: 365-257

Fax this form to (310) 841-0842

© 2007 POWELL

or call Customer Service at (800) 622 4456 or (310) 204-2224

Have your model number and part code letter handy.

Part Letter _____ Quantity _____

Name _____

Address _____

Daytime Phone () _____

Reason for replacement _____

Place of purchase _____