

Made in Malaysia

Thank you for Purchasing this Powell product. We want to make sure it is complete and to your satisfaction. Please check all packing material carefully for small parts which may have loose inside the carton during shipment. Hardware can be indentified by bright red packaging. Separate, identify, and count all parts and hardware to make sure they match with the illustrations herein and are all present. If any part(s) are missing or defective please contact Powell Customer Service. Contact information is given at the bottom of these instructions. If you feel the item is defective beyond a resolution with part replacements, please return this product with your receipt to the place of purchase. If purchased from an internet retailer , please contact their customer service department. Photo's and additional information may be requested to validate the claim. Product is not to be returned to the Powell Company under any circumstance unless authorized by the Powell Company or an authorized dealer or representative. Thank you.

ATTENTION : SOME LETTERED PARTS LISTED ON THE INSTRUCTION SHEET MAY NOT BE IN PARTS BAG AS THEY. MAY ALREADY BE ASSEMBLED. CAREFULLY CHECK PARTS AND PACKING MATERIALS PRIOR TO ORDERING REPLACEMENTS.

DURING ASSEMBLY OF CHAIR ONLY LOOSELY TIGHTEN ALL SCREWS. ONCE ASSEMBLED , STAND CHAIR UPRIGHT ON A FLAT SURFACE THEN FULLY TIGHTEN SCREW.

Tools Required for assembly : Phillips Screwdriver (Not included) ; Allen Wrench (G) (included)

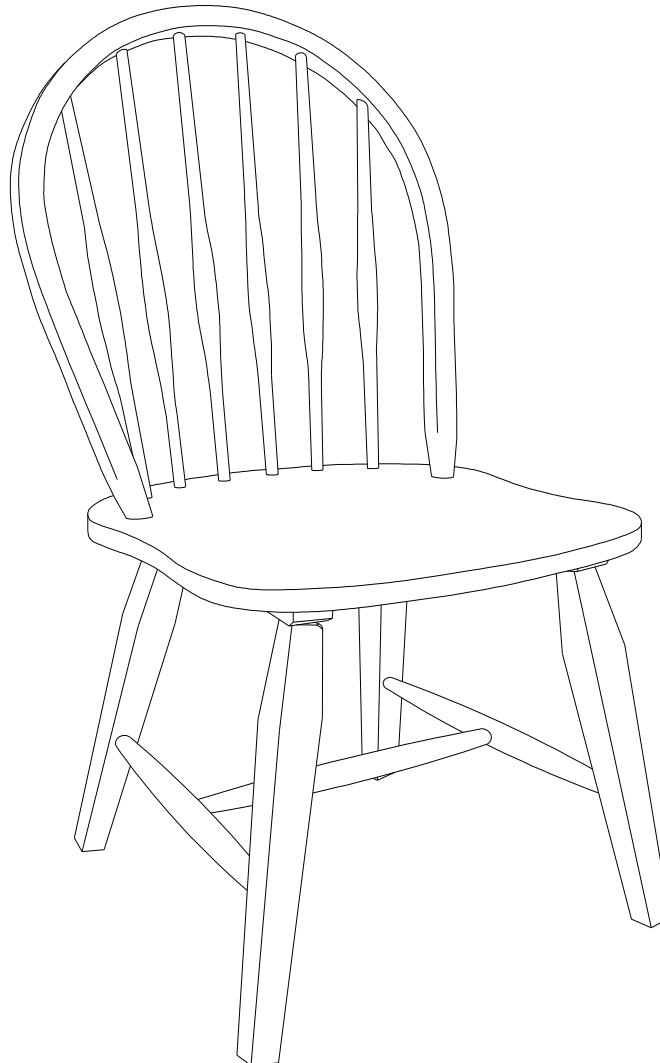

PARTS

- (A) CHAIR BACK (2PCS)
- (B) LEGS FRAME (4PCS)
- (C) CROSS BAR (2PCS)

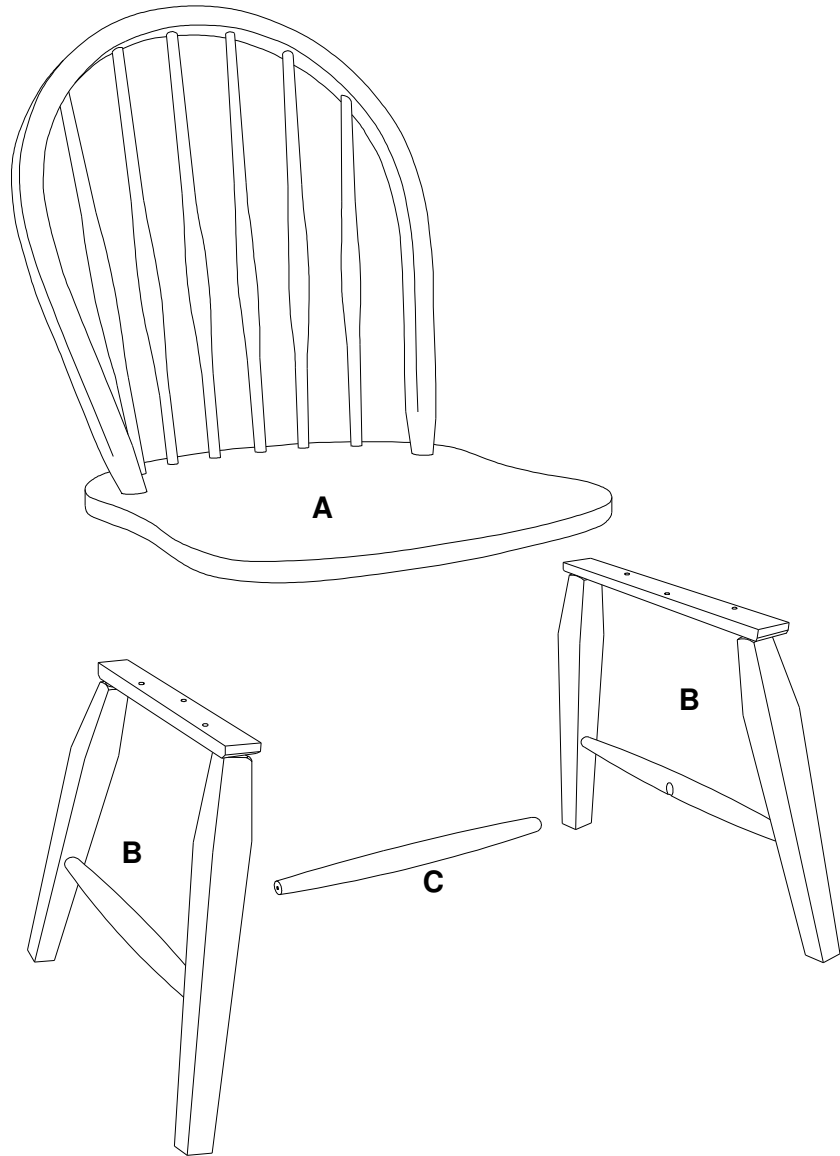

HARDWARE

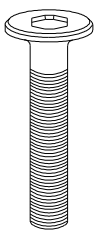

D
(4 PCS)

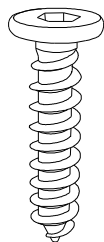

E
(12 PCS)

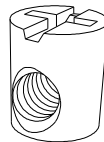

F
(4 PCS)

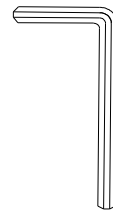

G
(1PC)



H
(4 PCS)

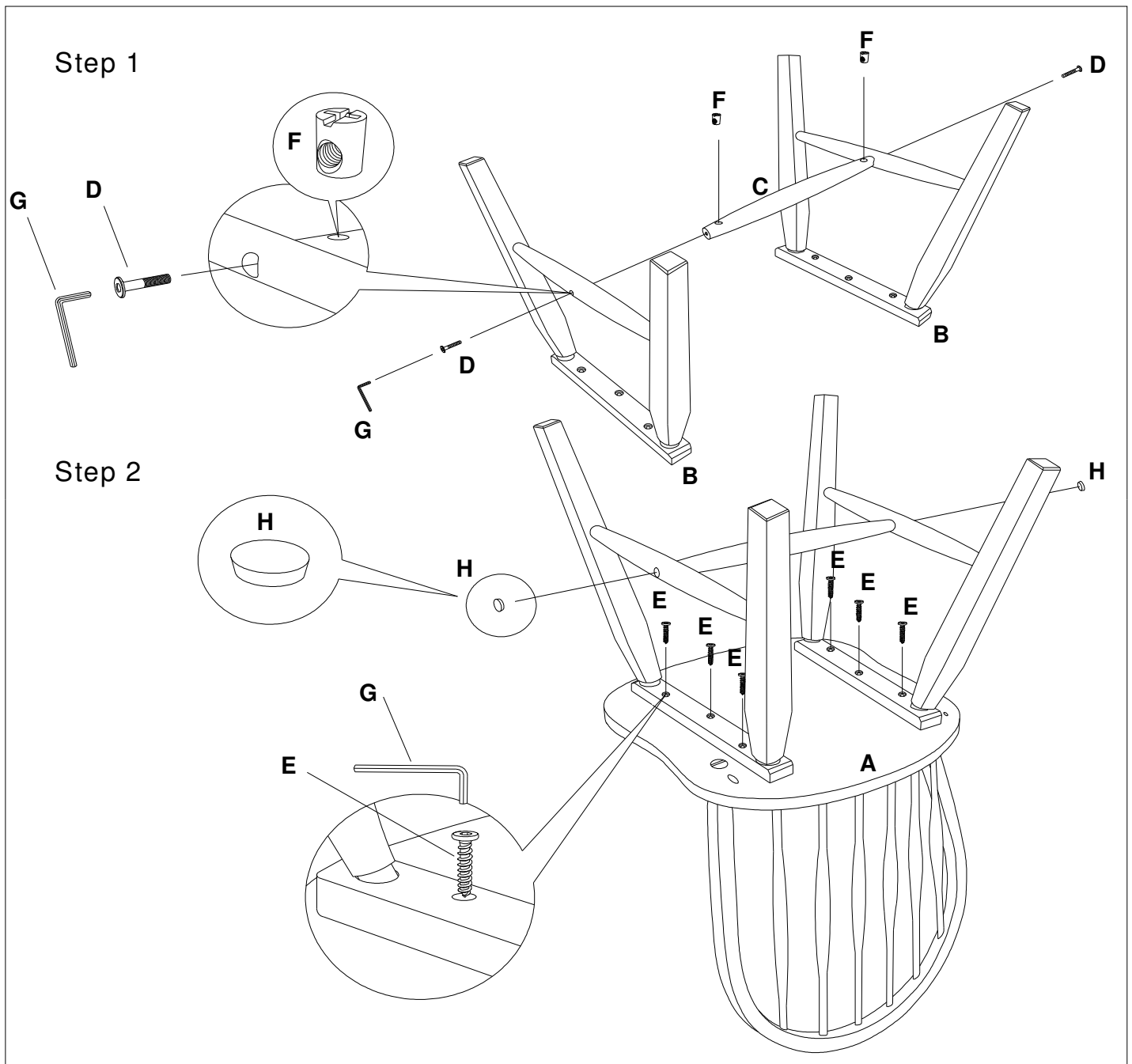

MODEL NO. 271- 436

Should there be any missing or defective part(S) , **place your part order on line at www.powellcompany.com** , or fax this form to (310) 841-0842 , or call Customer Service at (800) 622-4456.
 PLEASE HAVE THE MODEL NUMBER , PART CODE AND FACTORY CODE IDENTIFIED

Part Letter _____ quantity _____

Reason for replacement _____

Place for purchase _____

Date for purchase _____

Name _____

Address _____

City _____ State _____ Zip _____
 (No post office Box Addresses)

Best contact phone number (____) _____

Factory Code (MG) _____

Made in Malaysia

© 2008 Powell