

**TECHNICAL DATA SHEET -
SmartMount™ Articulating LCD Wall Arm**



**MODELS: SA740P, SA740P-S, RTFPA 220, RTFPA 220-S,
902220**



The SmartMount Articulating LCD Wall Arm supports 22" to 40" LCD screens. With internal cord management this mount folds flat against the wall or extends out up to 20". Its anodized aluminum finish elegantly complements offices, conference rooms, merchandising displays, hotel rooms or any room in the home. This two-link arm provides easy one-touch tilt and up to 180 degrees of swivel for virtually limitless viewing positions. Unsightly cords are routed internally within the arm to maintain the clean look of the installation. Ships pre-assembled for fast and easy installation.

Features:

- Fits 22" to 40" LCD screens
- Pre-assembled for fast and easy installation
- Comes with VESA 100mm/200mm/200 x 200mm screen adapter plate
- Non-VESA adapter plates available (sold separately)
- Three pivot points for virtually limitless adjustment that can be tightened to restrict movement
- 20° of smooth, continuous, one-touch tilt (5° up, 15° down)
- Offers up to 180° of swivel (depending on screen model)
- Adjustable roll of 7° in either direction allows screen to be easily leveled
- Anodized aluminum finish available in black or silver
- Built-in internal cord management conceals wires for a clean look
- Includes hardware for installation to a single wood stud or concrete
- UL tested to four times stated weight load

Accessories:

- Metal stud wall plate (WSP 420, WSP425, WSP430, WSP435, WSP440, WSP445)

Dimensions:

See Table

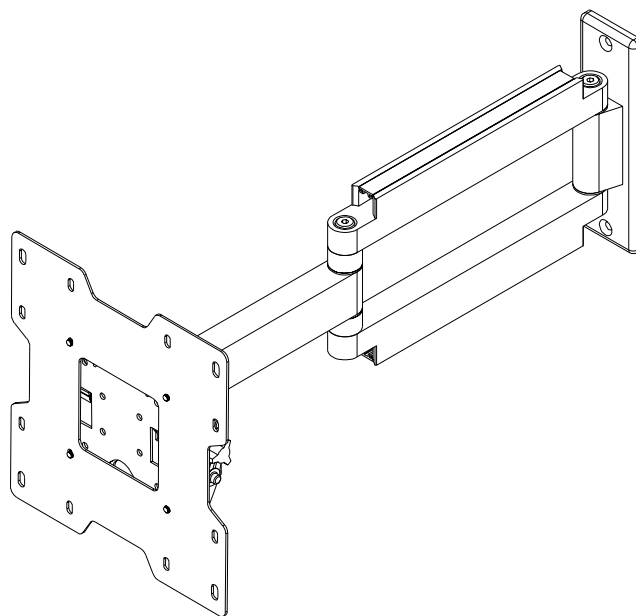

	SA740P, SA740P-S	RTFPA 220, RTFPA 220-S, 902220
Weight:	7.9 lb (3.6 kg)	7.9 lb (3.6 kg)
Shipping weight:	8.4 lb (3.8 kg)	8.7 lb (3.9 kg)
Maximum Load Capacity:	80.0 lb (36.3 kg)	80.0 lb (36.3 kg)
Shipping Carton dimensions:	L = 10.13 in (257 mm) W = 4.25 in (108 mm) H = 12.50 in (318 mm)	L = 10.19 in (259 mm) W = 4.31 in (109 mm) H = 12.63 in (321 mm)

ARCHITECTS SPECIFICATIONS

The SmartMount Articulating LCD Wall Arm shall be a Peerless model _____ and shall be located where indicated on the plans. Assembly and installation shall be done according to instructions provided by the manufacturer. Mount is made of anodized aluminum and adapter bracket is made of steel with a scratch resistant epoxy black or silver finish.

TECHNICAL DATA SHEET

MODELS: SA740P, SA740P-S, RTFPA 220, RTFPA 220-S, 902220

ALL DIMENSIONS = INCH (MM)

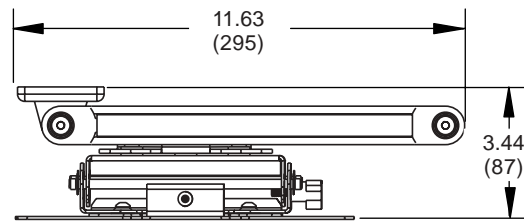
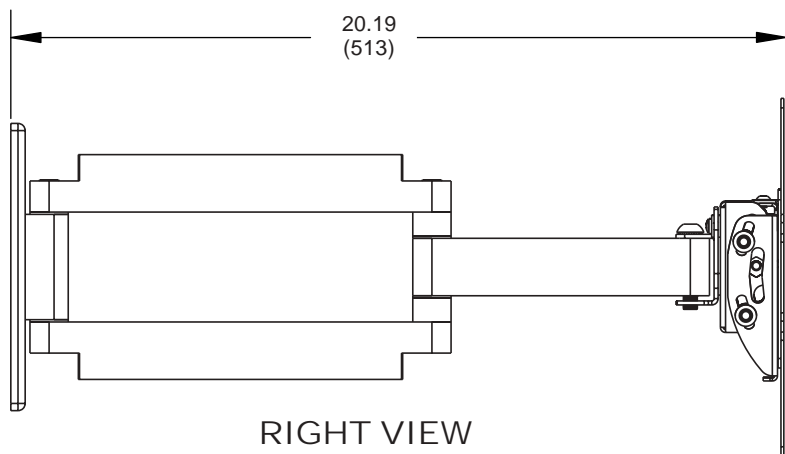

TOP VIEW

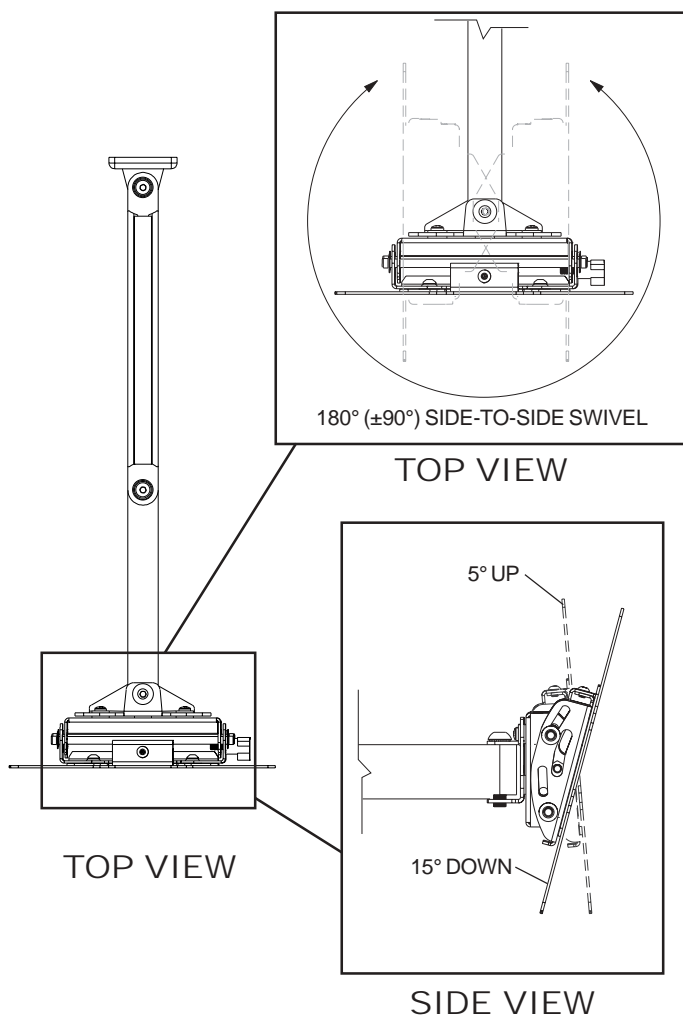

TECHNICAL DATA SHEET

MODELS: SA740P, SA740P-S, RTFPA 220, RTFPA 220-S, 902220

ALL DIMENSIONS = INCH (MM)

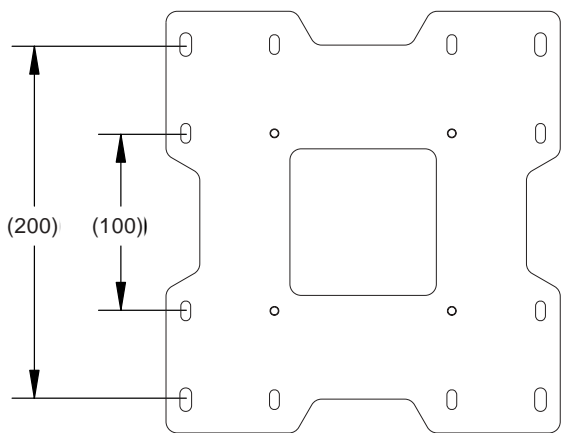
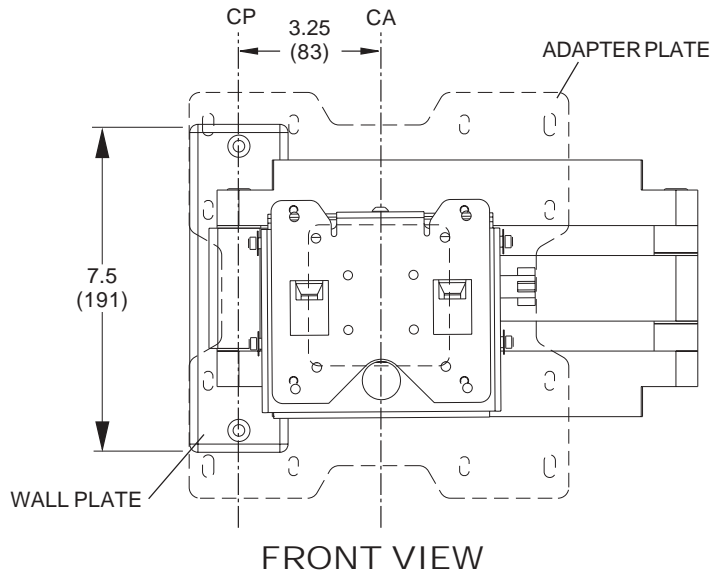

ADAPTER PLATE DETAIL

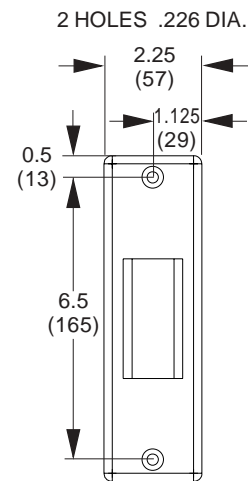

WALL PLATE