

TECHNICAL DATA SHEET - Pipe Reducer (1 1/2" - 3/4")



MODELS: ACC913



The **Pipe Reducer** allows FLP Series Extension columns (3/4") to be attached to most Peerless projector mounts and ceiling plates.

Features:

- Compact , lightweight, theft resistant design
- Can be used to attach 3/4" extension column to standard Peerless ceiling plates and projector mounts (2 required)
- Includes set screw for a secure installation

Dimensions:

Weight:

0.1 lb (0.05 kg)

Shipping weight:

0.2 lb (0.1 kg)

Shipping Carton dimensions:

L = 5.625" (143 mm)

W = 3.25" (83 mm)

H = 2.25" (57 mm)

Max. Load Capacity:

50 lb (23 kg)

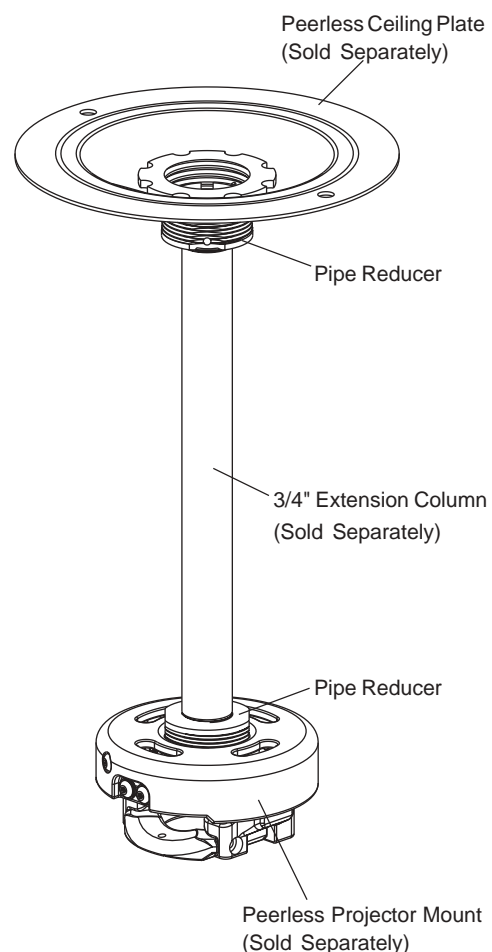

ARCHITECTS SPECIFICATIONS:

The Pipe Reducer shall be a Peerless model ACC 913. It shall be located where indicated on the plans. It shall be constructed of aluminum with black anodized finish. Assembly and installation shall be done according to instructions provided by the manufacturer.

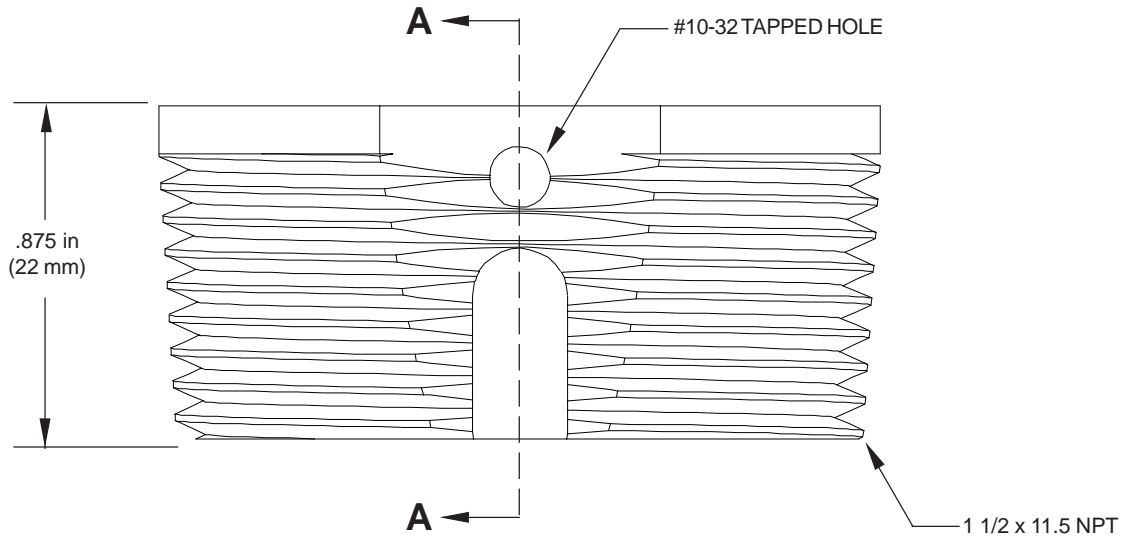

FRONT VIEW

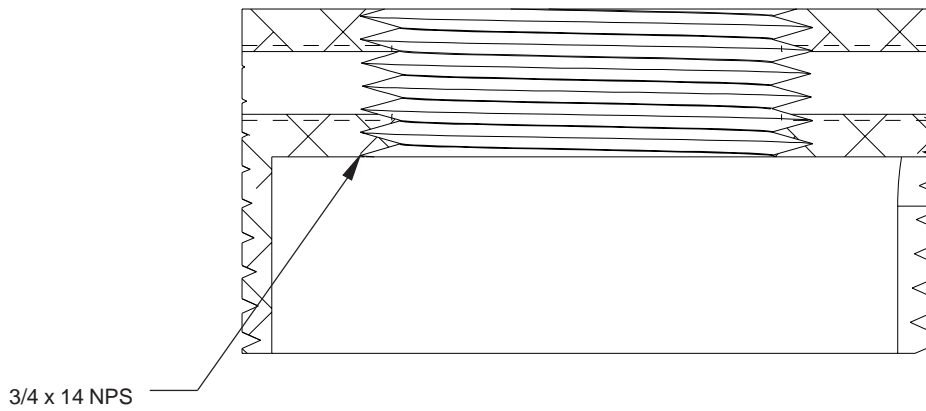

SECTION A-A