

## Installation and Assembly: Wide Base Cart

---

**Models:** JCT WB44, JCT WB44E

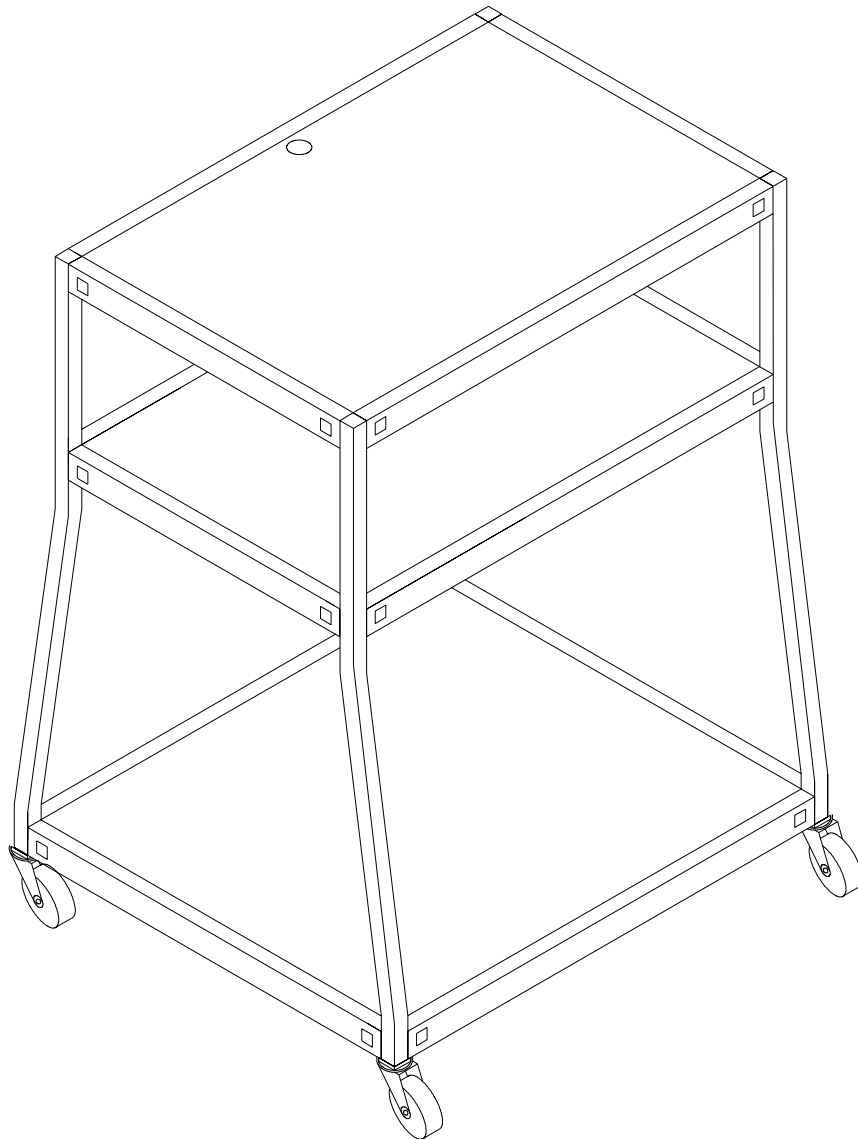

**Note:** Read entire instruction sheet before you start installation and assembly.

## ⚠ WARNING

- Do not begin to install your Peerless product until you have read and understood the instructions and warnings contained in this Installation Sheet. If you have any questions regarding any of the instructions or warnings, please call Peerless customer service at 1-800-729-0307.
- This product should only be installed by a qualified professional.
- Unit should be moved by authorized adults only.
- Prior to moving tables, place all AV equipment materials on lowest shelf possible. Secure heavy or bulky equipment to table with safety belts.
- Disconnect all electrical cords from wall outlets and secure to equipment on table.
- Unlock all casters, push mobile table from the narrow side of unit only. Never pull.
- Avoid rough or uneven flooring and remove any obstacles in your path.
- Apply force to the narrow side. Do not pull the unit.
- When set up for stationary use or when loading or unloading equipment, books, etc., always secure the casters before doing so.
- When using the table as an equipment stand, the equipment should be put on the lowest possible shelf that will still allow the equipment to operate correctly. The equipment should be placed in the center of the shelf it is sitting on.
- The product should not be used as a stool or a ladder.

## Parts List

| Description                                    | Qty. | Part #   |
|--|------|----------|
| <b>A</b> top shelf (displays Peerless logo)    | 1    | 009-1049 |
| <b>B</b> middle shelf                          | 1    | 009-1035 |
| <b>C</b> bottom shelf                          | 1    | 009-1034 |
| <b>D</b> legs                                  | 4    | 009-1041 |
| <b>E</b> carriage bolt                         | 24   | 520-1219 |
| <b>F</b> hex nut                               | 24   | 530-1026 |
| <b>G</b> washer                                | 24   | 540-1047 |
| <b>H</b> 4" casters without brakes (not shown) | 2    | 560-0082 |
| <b>I</b> 4" casters with brakes (not shown)    | 2    | 560-0083 |
| <b>J</b> Cord Wrap - Clip (JCT WB44E only)     | 1    | 009-1168 |
| <b>K</b> 15' Extension Cord (JCT WB44E only)   | 1    | 600-1011 |
| <b>L</b> phillips screw (JCT WB44E only)       | 2    | 520-1219 |
| <b>M</b> wingnut (JCT WB44E only)              | 2    | 530-1025 |
| <b>N</b> rubber mat                            | 1    | 009-1167 |

*Some parts may appear slightly different than illustrated.*

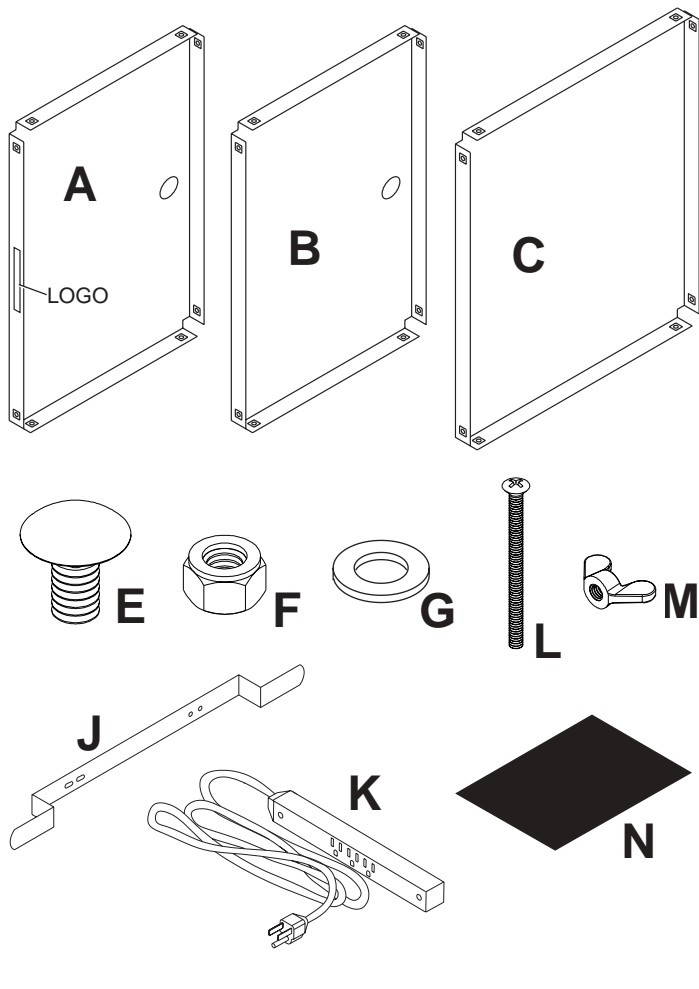

**1** Lay front legs (**D**) on the floor with the brackets facing upward and inward as illustrated.

**Notes:**

- Legs when placed on the floor should bend upward off the floor at their top end and the width of the unit should remain constant all the way to the top.
- Remove adhesive foam from brackets on legs to uncover holes.

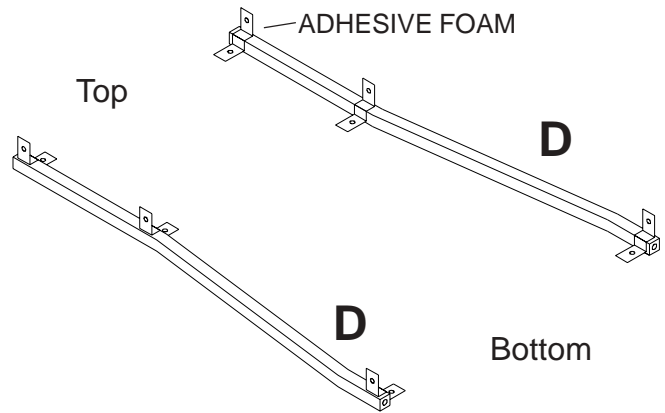

**2** Slide each shelf over the brackets of the legs (**D**). The largest shelf (**C**) is the bottom. The top shelf (**A**) has the *Peerless* logo on it and should face down during assembly.

**Note:** The top shelf (**A**) and middle shelf (**B**) are the same size but the top shelf has the *Peerless* logo on it.

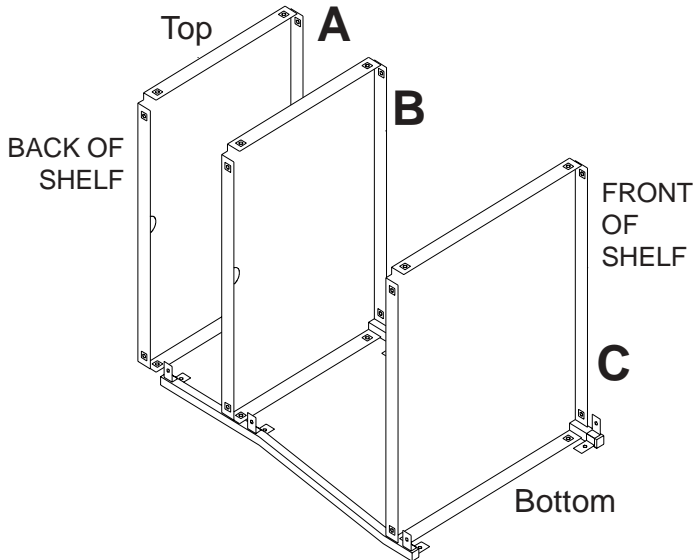

**3** Slide two remaining legs (**D**) onto the shelves as illustrated. Make sure that the brackets are inside the shelves.

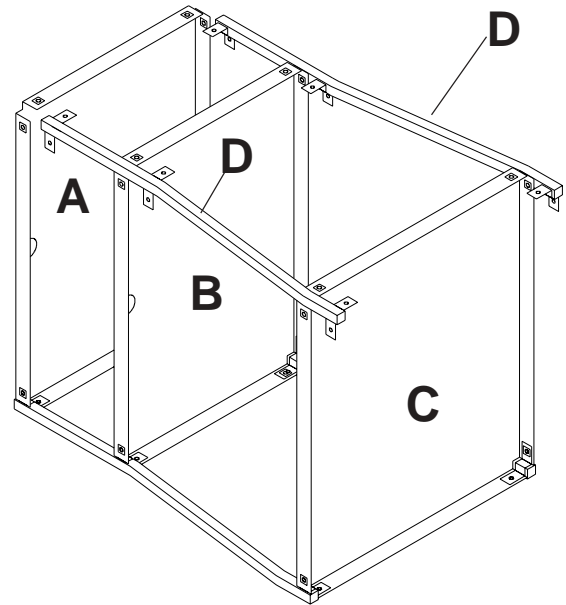

**4** Secure all shelves to the legs with supplied carriage bolts (**E**), washers (**F**), and nuts (**G**) as illustrated. Nuts should be on the inside of the unit.

**ONLY HAND TIGHTEN BOLTS AND NUTS AT THIS TIME.**

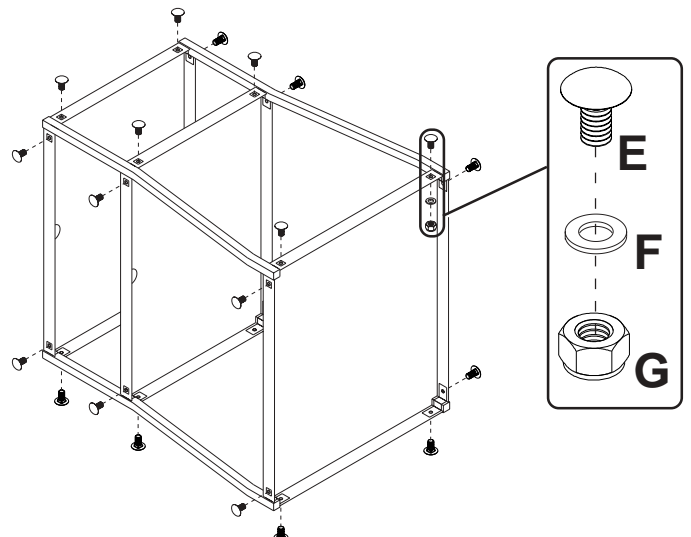

**5** It is very important that the next step be preformed on a level surface in order to have the unit properly aligned. Stand unit upright on a level surface. Gently rock unit back and forth to realign and level the unit. **TIGHTEN ALL NUTS (F) AND BOLTS (E) WITH WRENCHES AT THIS TIME.** Unit should now be properly aligned and level. If unit is not level at this time, repeat this step before proceeding to step 6.

**6** Lay unit on its back (logo on top shelf (A) should be facing up) and insert casters with brakes (I) into the front holes in the bottom of the cart. Insert the other casters (H) into the back holes of cart.

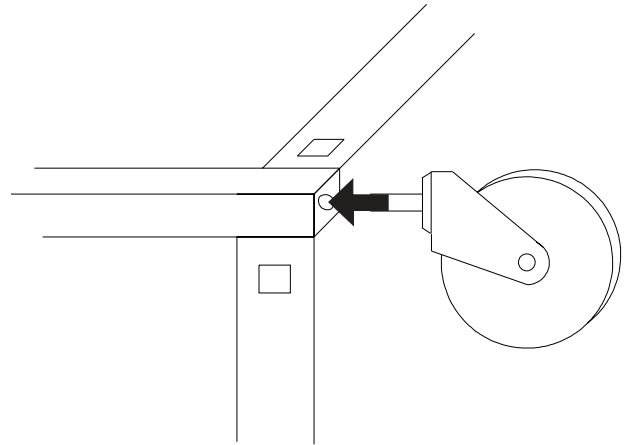

**This Step is for model JCT WB44E only!**

**8** Fasten cord wrap clip (J) and extension cord (K) to desired top shelf (A) using two phillips screws (L) and two wing nuts (M) as shown.

Wrap extension cord around cord clip.

