

Installation and Assembly- Encore™ Projector Mount
 Protected by U.S. Patent No. 6,042,068

Model: PJRL411

IMPORTANT! Read entire instruction sheet before you start installation and assembly.

WARNING! Installer must verify that the ceiling will safely support the combined weight of the Base Unit, Projector Adapter Plate, and video projector.

This product contains all mounting hardware for direct attachment to a wood joist ceiling. Concrete anchors (accessory kit ACC200, see page 2) sold separately. This product is to be used in combination with one of several **Projector Adapter Plates** (PAP models).

To order Projector Adapter Plates, Extension Columns, or additional mounting hardware call customer service at 1-800-729-0307 or 708-865-8870.

Before you start check the parts list below to make sure all of the parts shown are included.

Peerless Industries, Inc., 1980 Hawthorne Avenue, Melrose Park, IL 60160
 www.peerlessindustries.com



This product is intended for use with UL Listed products and must be installed by a qualified professional installer.

Parts List

Description	Qty.	Part Number
A projector mount ceiling plate	1	054-1003
B washer head wood screw #14 x 2.5 (6mm x 65mm)	2	5S1-015-C03
C M6 x 1 x 20mm socket head screw w/ flat and lock washer	9	520-1029
D security allen wrench	1	560-9646
E M5 x .8 x 8mm socket pin screw	2	520-1062
F main bracket assembly	1	054-1044
G fiber washer	1	540-9432
H retaining collar	1	1800-375
I M5 x .8 x 10mm socket pin screw	3	520-1164
J roll adapter bracket	1	054-1050
K interface bracket	1	055-1251

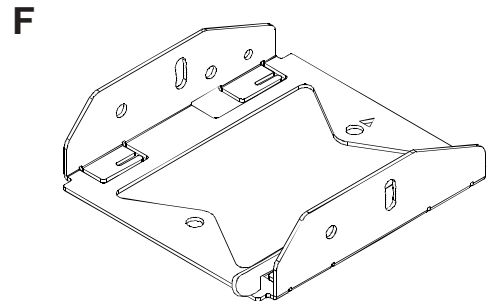
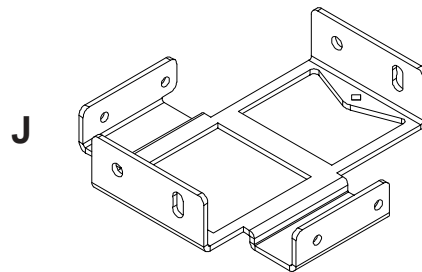
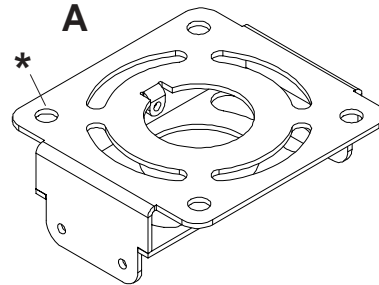

Note: Actual parts may appear slightly different than illustrated.

* Four .406 dia. holes provided for threaded rod installations. Materials and procedure for such installations are the sole responsibility of the installer.

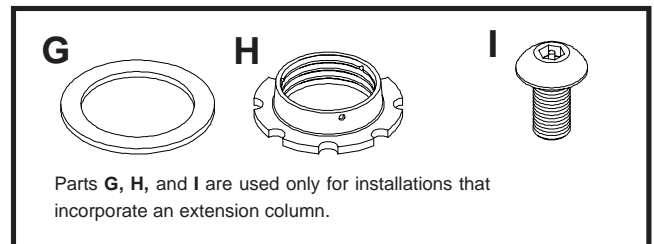
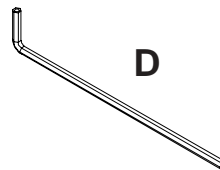
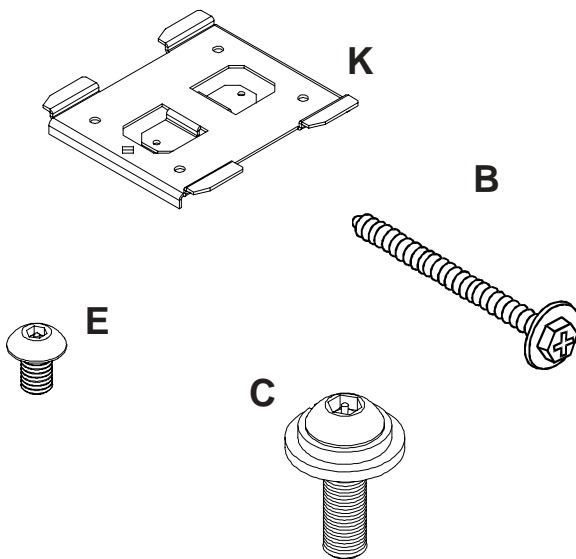

Parts G, H, and I are used only for installations that incorporate an extension column.

©2003 Peerless Industries, Inc. All rights reserved.
 Peerless is a registered trademark of Peerless Industries, Inc.
 Encore is a trademark of Peerless Industries, Inc.
 All other brand and product names are trademarks or registered trademarks of their respective owners.

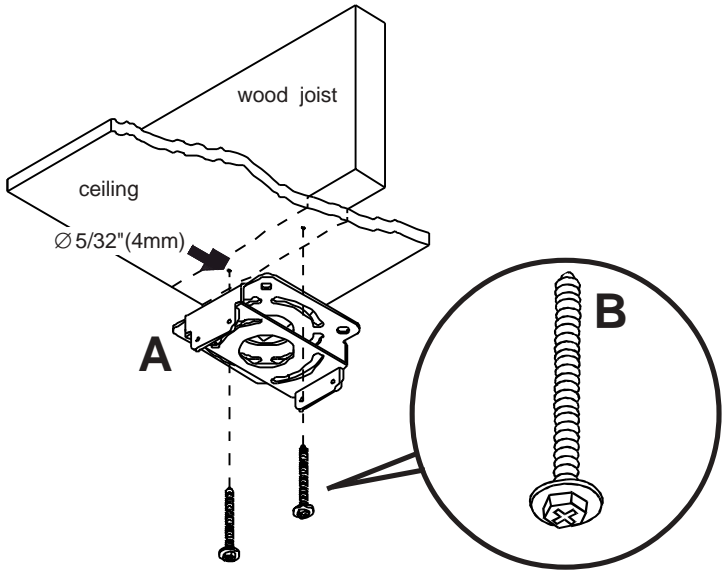

- 1 Attachment to a Wood Joist.** Use a stud finder to locate ceiling joist. Drill two 5/32" (4mm) dia. holes 2.5" (65mm) deep into **joist center**. Attach projector mount ceiling plate (A) using #14 x 2.5" (6mm x 65mm) wood screws (B).

CAUTION: Tighten wood screws so ceiling plate is firmly attached. But **DO NOT TIGHTEN WITH EXCESSIVE FORCE!** Overtightening can cause stress damage to wood screws, greatly reducing their holding power!

Tighten to 80 in. lbs. (9 N.M.) maximum torque.
BE SURE TO DRILL INTO JOIST CENTER!
Skip to Step 4

USE ONLY RAWL™ #5005 OR HILTI™ HL814 CONCRETE EXPANSION ANCHORS [.312 x 1.625 (8mm x 41mm)]. Order accessory kit #ACC200.

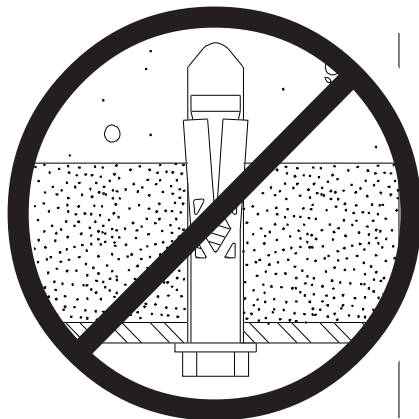

THESE CONCRETE ANCHORS ARE FOR DIRECT ATTACHMENT TO LOAD BEARING CONCRETE ONLY! NOT FOR ATTACHMENT TO CONCRETE CEILING COVERED WITH PLASTER, DRYWALL, TILE OR OTHER FINISHING MATERIAL!

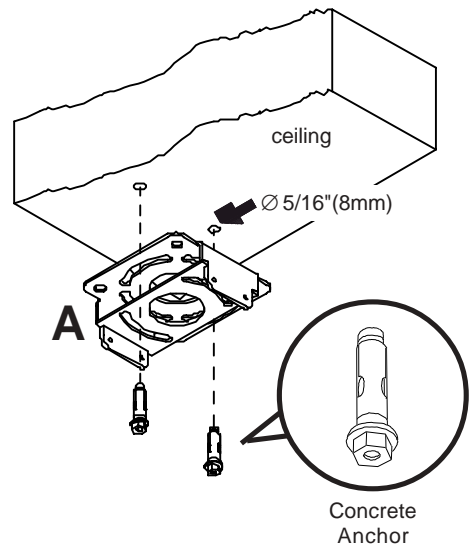

- 2 Attachment to a Concrete Ceiling.**
NOTE: Concrete anchors are sold separately. Order accessory kit #ACC200. Drill two 5/16" (8mm) dia. holes 1.75" (45mm) deep. Attach projector mount ceiling plate (A) using two concrete anchors. *Tighten to 80 in. lbs. (9 N.M.) maximum torque.* See also **CONCRETE ANCHOR INSTALLATION** below. **Skip to Step 4**

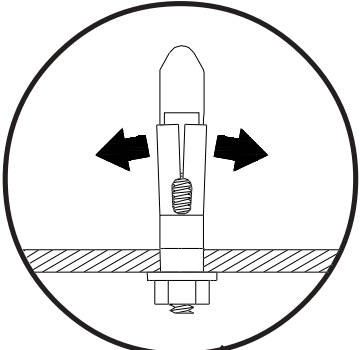

CROSS SECTION

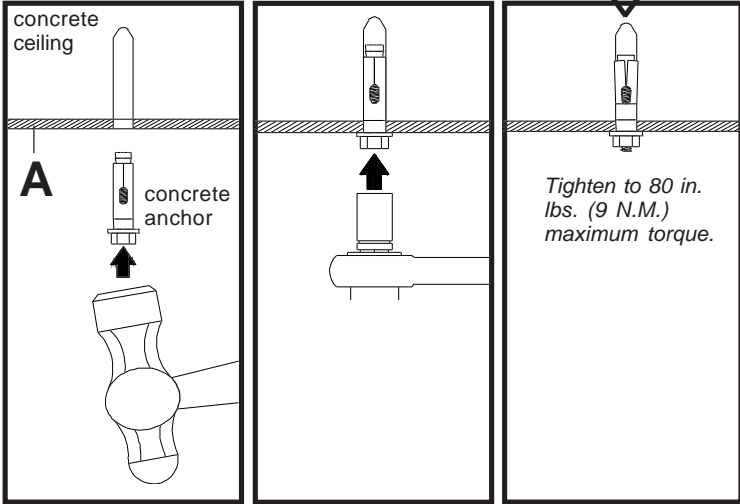

CONCRETE ANCHOR INSTALLATION

3**Extension column applications only:**

Insert end of extension column into threaded fitting in ceiling plate. Tighten securely - four or five complete turns. Align slot in extension column with one of the small holes in the side of the threaded fitting. Insert and tighten one M5 x .8 x 10mm socket pin screw (I) into hole to lock extension column to threaded fitting. Tighten screw allen wrench (D).

WARNING: For safety, extension column must be locked to threaded fitting with screw (I)!

Attach projector mount ceiling plate (A) with fiber washer (G) and retaining collar (H). Tighten retaining collar securely, four or five complete turns, aligning one hole in the side of retaining collar with slot in the end of extension column. From **inside** insert and tighten one M5 x .8 x 10mm socket pin screw (I) into hole in retaining collar. Tighten screw with allen wrench (D).

Note: You may need to thread the socket pin screw from the outside first (approximately 3 turns) to loosen any buildup that may be on the threads.

WARNING: For safety, retaining collar must be locked to extension column with screw (I)!

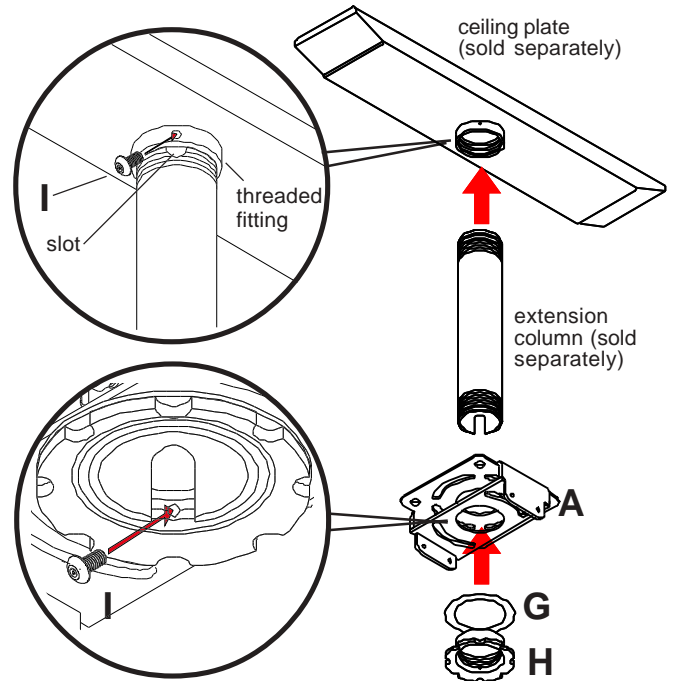
**4**

Attach roll adaptor bracket (J) to ceiling plate (A) using four M6 x 1 x 20mm socket head security screws (C). Tighten using 4mm allen wrench provided. Next attach main bracket (F) using remaining fasteners (C). Tighten using 4mm allen wrench provided.

IMPORTANT: Do not lose or dispose of allen wrench. It will be required to attach the Projector Adapter Plate.

NOTE: Arrow indicates front of main bracket (F).

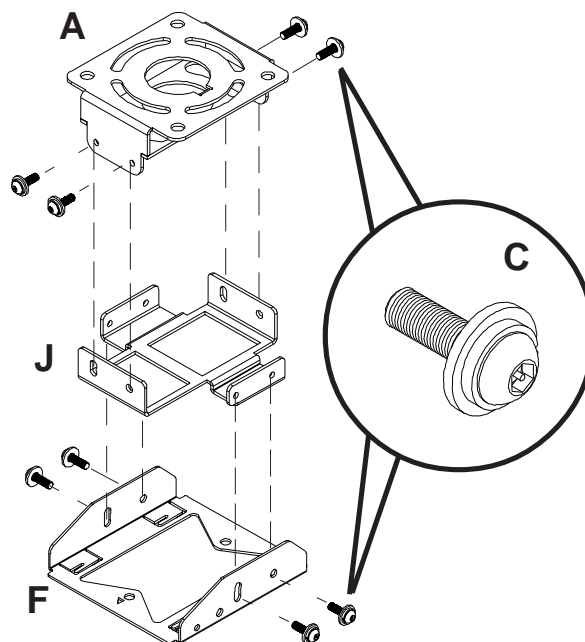

Note: Attach adapter plate to projector (see PAP instructions) prior to proceeding to step 5

Note: The Projector Adapter Plate and projector you are installing may differ in appearance from the sample illustrated below.

- 5** Place interface bracket (K) on top of adapter plate as shown.

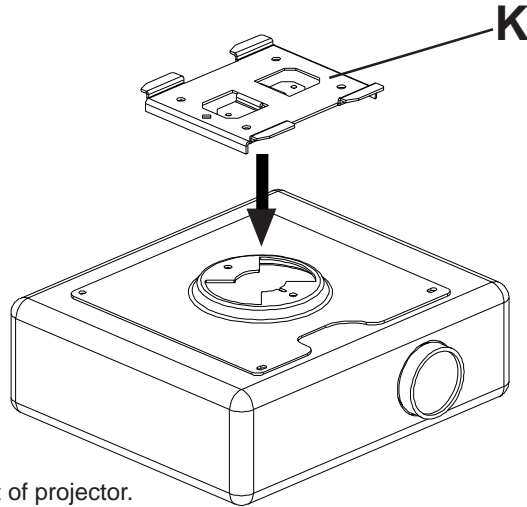

- 6** **NOTE:** # Notch on interface bracket indicates front of projector.
*Notch on adapter bracket indicates front of projector.

Rotate interface bracket until the two holes line up with two holes on adapter plate. Make sure that both front of interface bracket (K) and projector adapter plate are closely aligned.

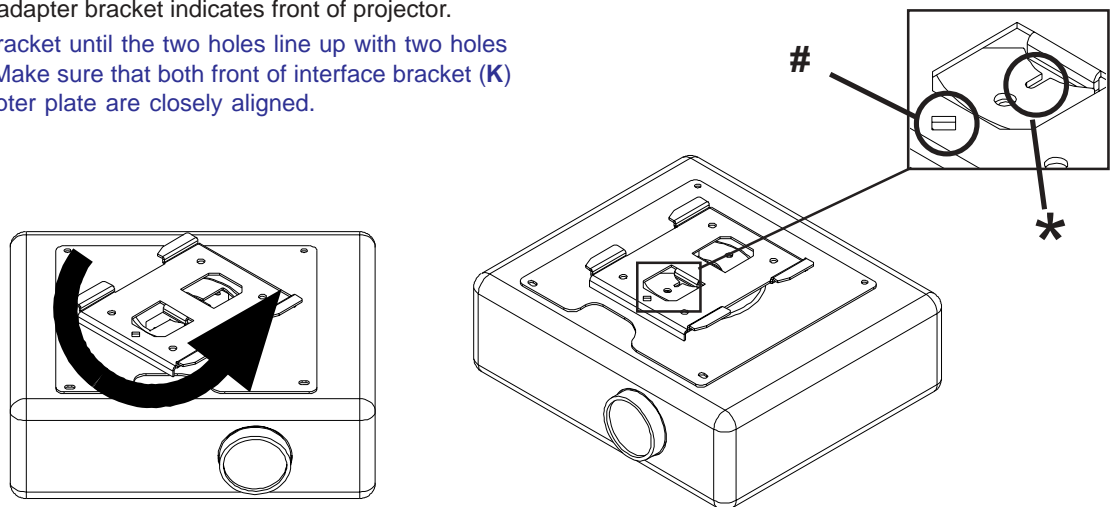

- 7** Fasten interface bracket (K) to adapter plate using two M5 socket-pin screws (E). Tighten screws (E) using 4mm allen wrench (K).

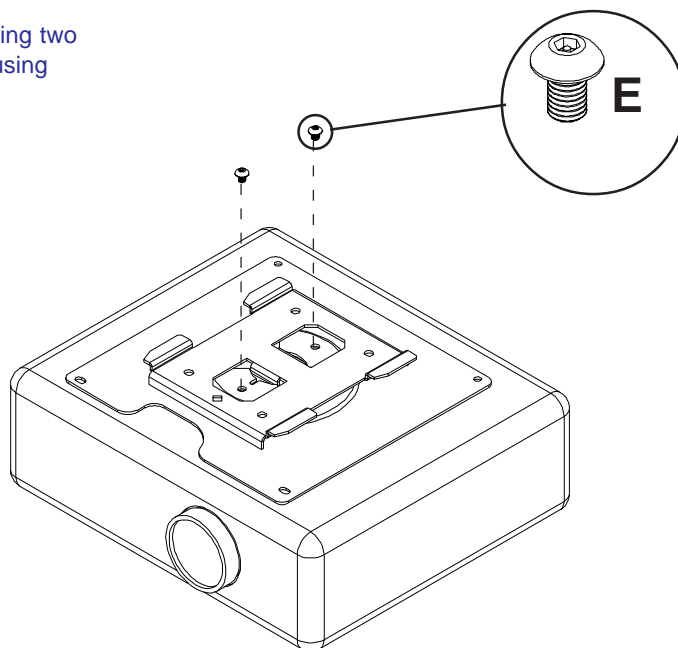

- 8** Position four tabs in **interface bracket (K)** behind four tabs in base unit. Slide forward to engage latch. **BE SURE THAT LATCH IS ENGAGED!**

WARNING:
Do not lift more weight than you can handle! Use additional man power or mechanical lifting equipment to safely handle placement of the video projector!

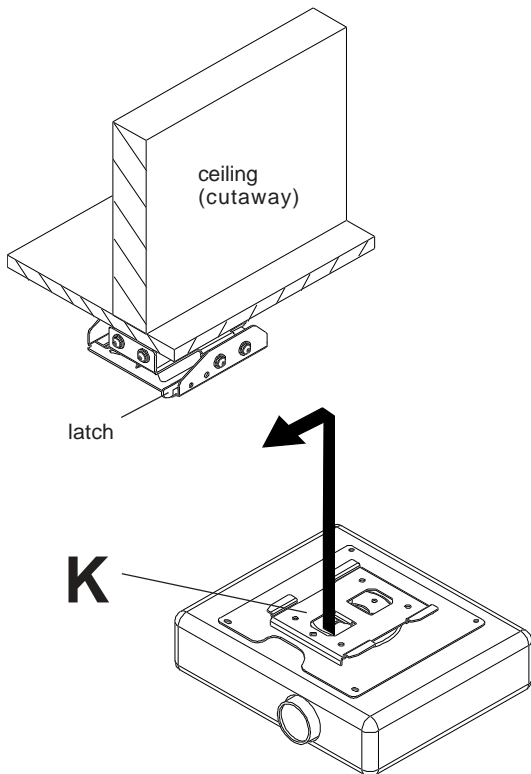

SECURITY OPTION

Lock the latch by tightening M6 x 1 x 20mm socket head security screw (**C**) through hole in base unit, into threaded hole in latch. Tighten using 4mm allen wrench.

IMPORTANT: Allen wrench is your key for projector removal. Store it in a safe place.

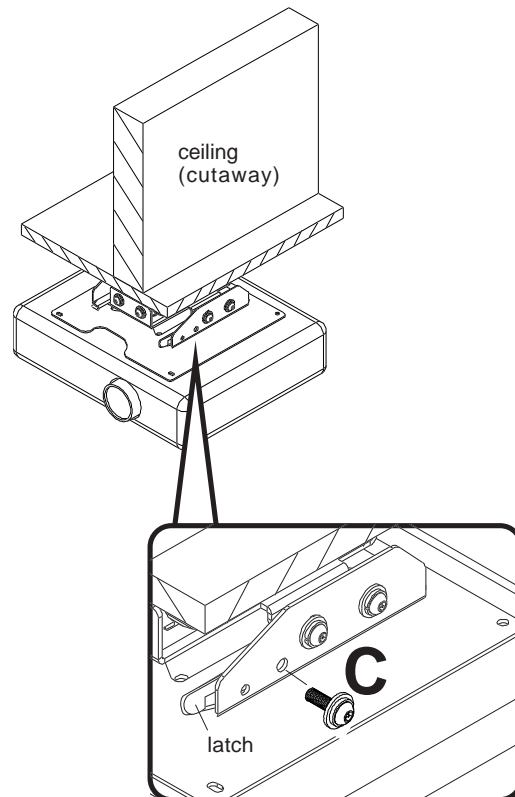

9 Final Alignment

To adjust Yaw (swivel) for flush mounting applications: Loosen wood screws until projector mount can be rotated. Rotate mount to desired position and retighten screws.

To adjust Yaw (swivel) for extension column applications: Rotate mount to desired position. Insert and tighten one remaining socket pin screw (**I**) into tab in projector mount ceiling plate (**A**) as shown below.

To adjust pitch (forward and backward tilt), loosen the two screws on each side of the main bracket assembly (**F**). Tilt mount to desired position and tighten screws.

To adjust roll (side to side tilt), loosen the two screws on each side of the roll adapter bracket (**J**). Tilt mount to desired position and tighten screws.

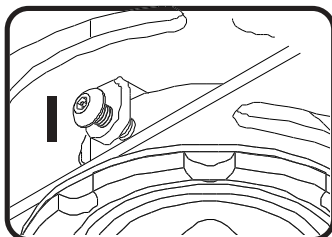

Peerless offers several Projector Mounts to fit various video projectors. New Projector Mounts are continually being developed to meet the demands of a growing projector market. To find out if a mount is available for your particular projector call Peerless customer service at 1-800-729-0307 or 708-865-8870.