

Electrical Outlet Strip				
Weight	*Shipping Weight	Dimensions		
		W	D	H
2 lbs. (1 kg)	2.2 lbs. (1 kg)	1.25" (32 mm)	5.375" (137 mm)	1.25" (32 mm)

* Shipping weight based on single unit shipment. Per unit shipping weight may be less for bulk orders.

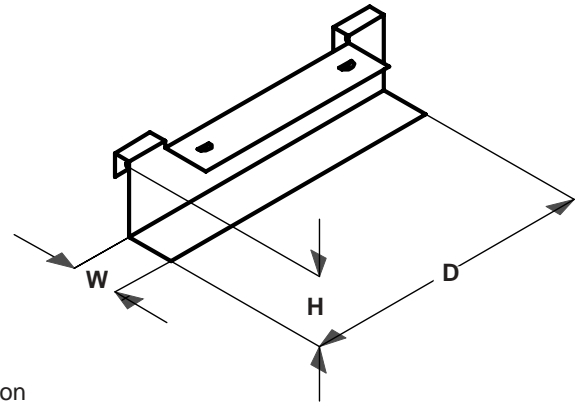

DIMENSIONS

The Electrical Outlet Strip is designed to hold a Peerless Extension Cord to the horizontal cross supports of the jumbo 2000 mounts. It can virtually be used with any of the Peerless product.

Features:

- 20' extension cord
- Scratch-resistant black fused epoxy finish

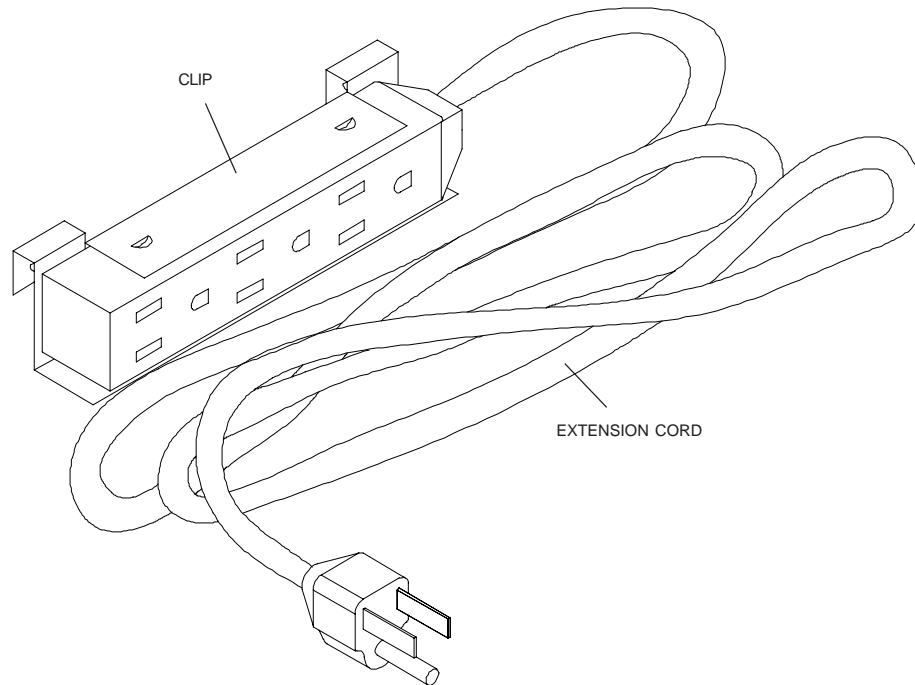

ISOMETRIC VIEW

ARCHITECTS SPECIFICATIONS

The Electrical Outlet Strip shall be a Peerless model ACC551 and shall be mounted where indicated on the plans. It shall be constructed primarily of 14 gage cold rolled steel and finished in black fused epoxy. Assembly and installation shall be done according to the instructions provided by the manufacturer.



Peerless Industries, Inc. 3215 W. North Ave. Melrose Park, IL 60160
708-865-8870 800-865-2112 Fax 708-865-2941 www.peerlessindustries.com

TECHNICAL DATA SHEET

Electrical Outlet Strip

Issued: 05-19-99 Sheet No. 128-9519 12-11-03 page 1 of 1