

TECHNICAL DATA SHEET - Environmental Enclosure EE Pedestal Support Column



MODELS: EE 410R, EE 510R, EE 610R, EE 710R, EE 810R

The EE pedestal mount offers 4 different lengths from the floor to accommodate installation requirements. The EE pedestals are for use with Peerless Environmental Enclosures only.

Features:

- Color: Light Gray - Other colors available upon request
- Ranges from 4' to 8' depending on installation requirement
- Maintains industry leading wind capacity ratings
- Built in cord management
- Designed to handle maximum wind speeds up to 110 mph
- For use with EE 20 and EE 27 Environmental Enclosures only
- Mounts to 3000+ psi cement only
- Weather-coated

Dimensions:

Maximum Load Capacity:
300 lb (136.1 kg)

See page 2 for more dimensions

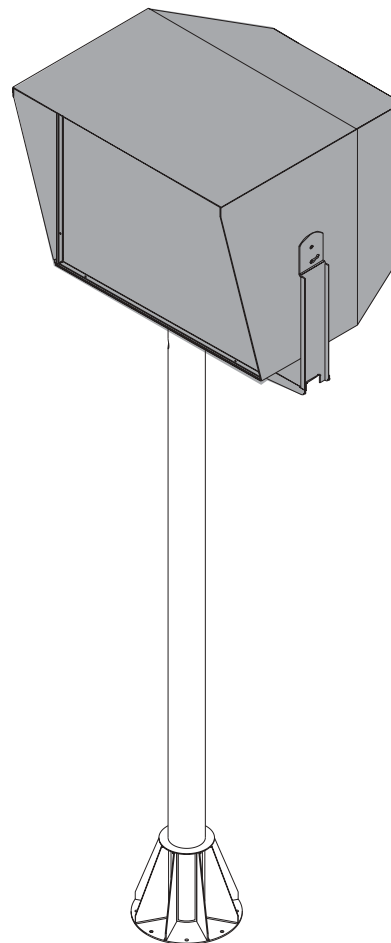

This product is wind rated to 110 mph up to Exposure D, 200' Elevation, per Uniform Building Codes (UBC).

ARCHITECTS SPECIFICATIONS

The Environmental Enclosure EE Pedestal Support Column shall be a Peerless model _____ and shall be located where indicated on the plans. It shall be light gray powdered, UV, scratch & weather resistant, wind rated with E-coated primer and a powder coat finish. Assembly and installation shall be done according to instructions provided by the manufacturer.

TECHNICAL DATA SHEET

MODELS: EE 410R, EE 510R, EE 610R, EE 710R, EE 810R

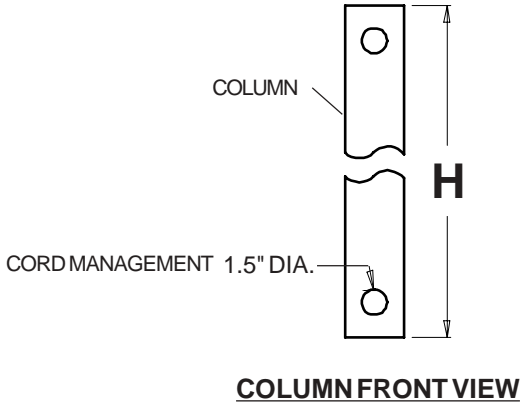

Dimensions				
MODEL	H	WEIGHT	SHIPPING WEIGHT	CARTON DIMENSIONS
EE410R	4' (1.2m)	68.5 lb (31.1 kg)	84.6 lb (38.4 kg)	52" x 20" x 19.5" (132 cm x 51 cm x 50 cm)
EE510R	5' (1.5m)	78.3 lb (35.5 kg)	95 lb (43.1 kg)	64" x 20" x 19.5" (163 cm x 51 cm x 50 cm)
EE610R	6' (1.8m)	88.1 lb (40 kg)	104.8 lb (47.5 kg)	76" x 20" x 19.5" (193 cm x 51 cm x 50 cm)
EE710R	7' (2.1m)	97.9 lb (44.4 kg)	115.2 lb (52.3 kg)	88" x 20" x 19.5" (224 cm x 51 cm x 50 cm)
EE810R	8' (2.4m)	110.3 lb (50 kg)	127.7 lb (57.9 kg)	100" x 20" x 19.5" (254 cm x 51 cm x 50 cm)

