

TECHNICAL DATA SHEET - PLASMA SCREEN PEDESTAL

MODELS: COL 510P, COL 610P, COL 710P, COL 810P



Solid Solutions - Solid Support

Used to support 42" - 50" plasmas on a fixed position, heavy duty floor pedestal from 5' - 8' in height.

Features:

- Choice of 5', 6', 7' or 8' pedestal height
- Concrete floor anchors included
- 360 degree swivel with swivel stop
- 0-15 degree tilt
- Screen can be mounted either horizontally or vertically
- Screen orientation can be easily adjusted after installation
- Pedestal used in conjunction with plasma bracket (purchased separately)
- Black scratch resistant finish

Dimensions:

For dimensions and weights, see page 2.

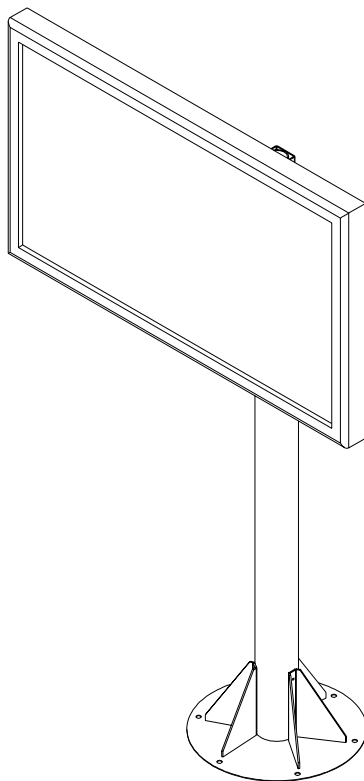

ARCHITECTSSPECIFICATIONS:

The plasma adapter bracket shall be a Peerless model _____ and shall be used in combination with Peerless model _____ column. It shall have 360° swivel with swivel stop. It shall be constructed of heavy gauge cold rolled steel. It shall mount vertically or horizontally with 0° to 15° of tilt. The finish shall be scratch resistant black fused epoxy. Assembly and installation shall be done according to instructions provided by the manufacturer.

Peerless Industries, Inc.
 3215 W. North Ave. Melrose Park, IL 60160
 708-865-8870 800-865-2112 Fax 708-865-2941
www.peerlessindustries.com

ISSUED: 04/09/01 SHEET NO: 200-9617-1 12/19/01

©2001 Peerless Industries, Inc. All rights reserved.
 Peerless is a trademark of Peerless Industries, Inc.

TECHNICAL DATA SHEET

MODELS: COL 510P, COL 610P, COL 710P, COL 810P

PLASMA SCREEN AND ADAPTER BRACKET MAY BE DIFFERENT THAN ILLUSTRATED.

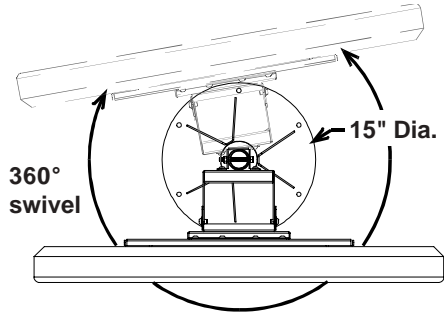

Dimensions:

	H
COL 510P	68.15"/1731mm
COL 610P	80.15"/2036mm
COL 710P	92.15"/2341mm
COL 810P	104.15"/2645mm

	D
All Models	14.48"/368mm

	Weight:	Shipping weight:
COL 510P	35 lbs. / 16 kg.	36 lbs. / 16.4 kg.
COL 610P	38 lbs. / 17.3 kg.	39 lbs. / 17.7 kg.
COL 710P	41 lbs. / 18.6 kg.	42 lbs. / 19 kg.
COL 810P	44 lbs. / 20 kg.	45 lbs. / 20.4kg.

Maximum Load Capacity: 150 lbs. / 68 kg.

