

Installation and Assembly - VCR Mount for Slimline Standard Wall Mount

Models:
VPM35-W, VPM40-W, VPM45-W,
SVPM35-W, SVPM40-W, SVPM45-W

MODEL #	INSIDE DIMENSIONS	
	WIDTH (W)	HEIGHT (H)
VPM35-W, SVPM35-W	10.25" - 14.25" (260mm - 362mm)	2.69" - 4.5" (68mm - 114mm)
VPM40-W, SVPM40-W	13.25" - 17.25" (337mm - 438mm)	2.69" - 4.5" (68mm - 114mm)
VPM45-W, SVPM45-W	13.25" - 17.25" (337mm - 438mm)	4.25" - 5.75" (108mm - 146mm)

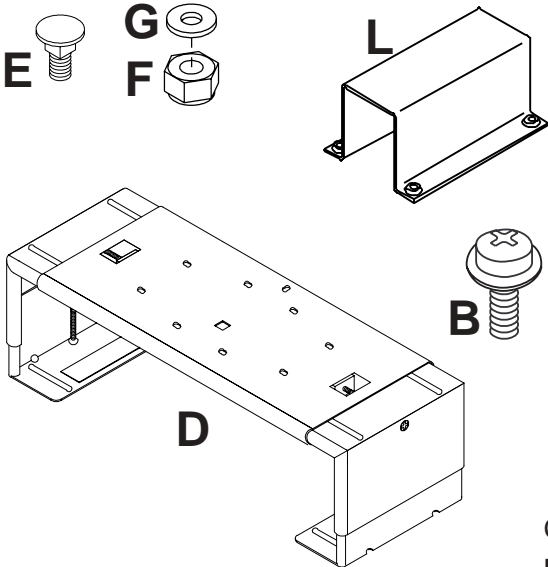

						Parts List		
VPM35-W	SVPM35-W	VPM40-W	SVPM40-W	VPM45-W	SVPM45-W	Description	Qty.	Part Number
✓	✓	✓	✓	✓	✓	B M5 x .8 x 10mm phillips screw	4	520-1030
	✓		✓		✓	C penta-pin tool (not shown)	1	520-9249
✓	✓	✓	✓	✓	✓	D VCR bracket	1	—
✓	✓	✓	✓	✓	✓	E 10-24 x 1/2 carriage bolt	4	520-9523
✓	✓	✓	✓	✓	✓	F 10-24 nylock nut	4	530-9341
✓	✓	✓	✓	✓	✓	G #10 SAE flat washer	4	540-9400
✓	✓	✓	✓	✓	✓	L hanger bracket	1	1245-271

Parts may appear slightly different than illustrated.

Check parts list. Be sure all parts listed are included with your product.

Note: The PentaPin tool is only included with security models (SVPM models)

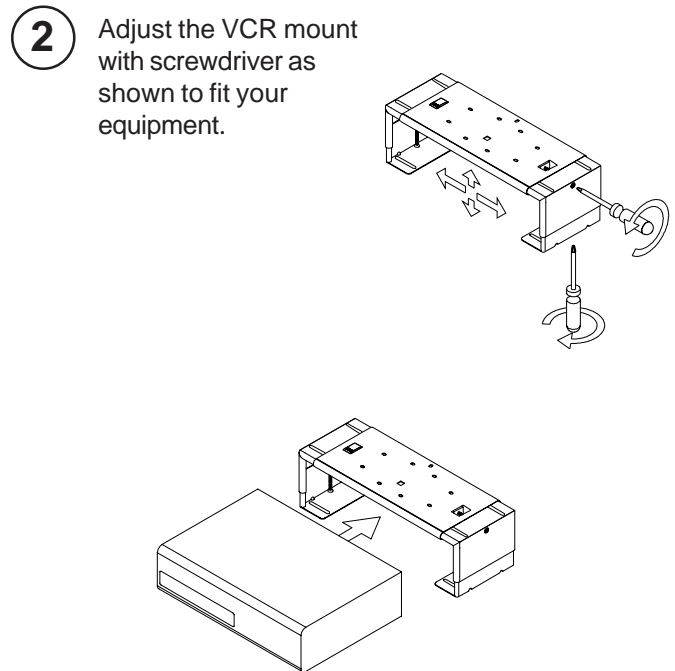
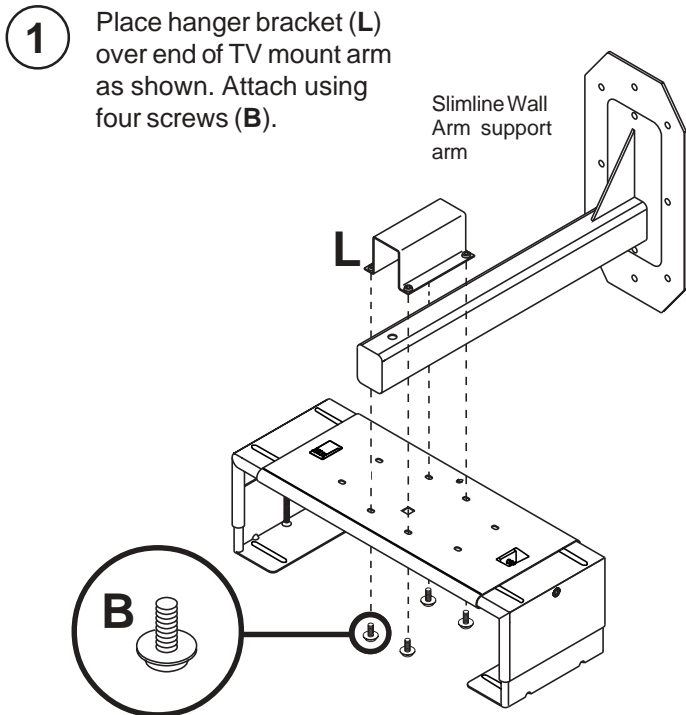

OPTIONAL: If attaching multiple VCR mounts to a TV mount, proceed with step 3 through 5

IMPORTANT! Do not stack more than three VCR Mounts from a single Peerless TV Mount!

IMPORTANT! Stacked load can not exceed 50lbs.

- 3** Insert four carriage bolts (E) into slots in upper VCR Mount. Attach lower VCR Mount using four nuts (F) and four washers (G). **HAND TIGHTEN ONLY.**
Note: if adhesive pads on VCR Mount are covering slots, trim away excessive pad to expose slots.

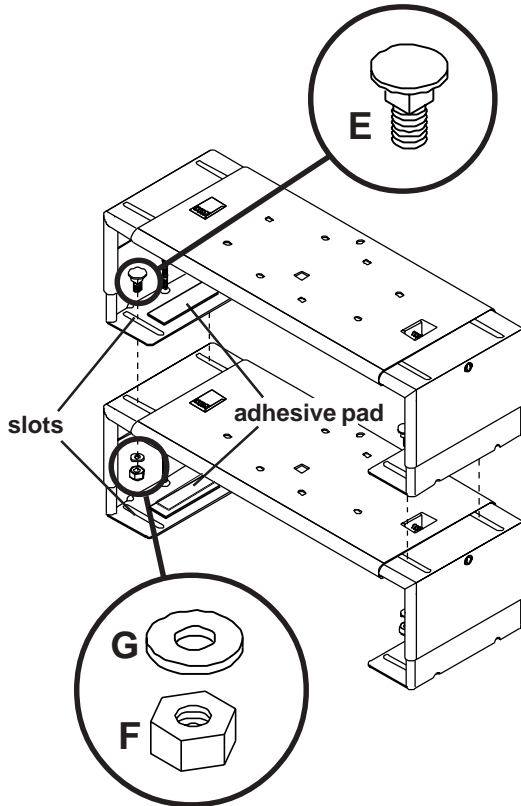

- 4** Insert VCR into upper VCR Mount.

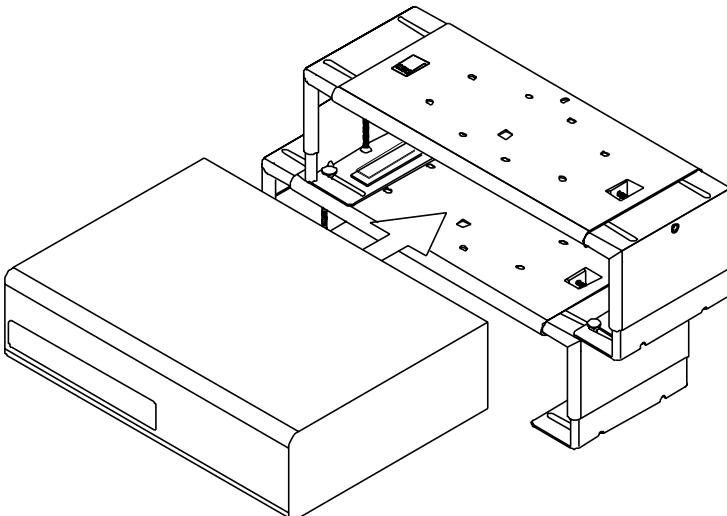

- 5** Align front of VCR with front of TV on TV Mount above (TV Mount not pictured). Tighten expansion screws in sides and bottom of VCR Mount to clamp the VCR with a firm, secure grip.

Note: To access the vertical expansion screws located on the bottom of the upper VCR Mount, slide the lower VCR Mount to the side exposing vertical expansion screw. Repeat this step on opposite side of VCR Mount. Center lower VCR Mount and tighten four nuts (F, see step 3) securely.

Expand lower VCR Mount to slightly larger than the height and width of the VCR that it will hold. Insert and clamp lower VCR into lower VCR Mount.

