

FAUCET DESCRIPTION

- Chrome plated brass construction
- 8" centers
- 1/2" IPS connections
- Less spout

OPERATION

- 4" wrist blade handles with hot and cold color indicators and vandal resistant screws

CARTRIDGE

- Ceramic 28mm cartridge design
- Nonmetallic and nonferrous material
- 1/4 turn operation

STANDARDS

- Designed and manufactured to comply with the requirements of: CSA B-125 and ASME A112.18.1M and all specifications referenced therein and complies with the requirements of ANSI A117.1
- Certified to ANSI/NSF 61/9
- Complies with California Proposition 65 and the Federal Safe Drinking Water Act

WARRANTY

- Warranted for 5 years against material or manufacturing defects

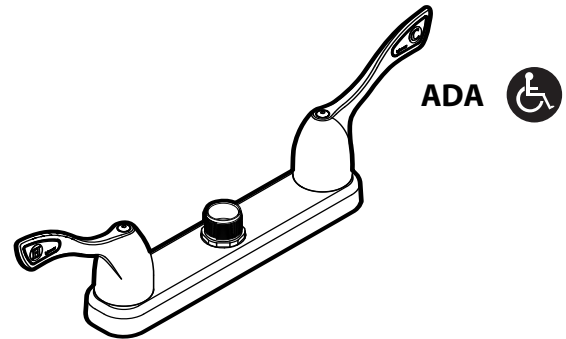

Two-Handle Deck Faucet

Model: 8123

NOTE: DESIGNED TO INSTALL THROUGH 2 1" MIN. DIA. HOLES. 8" ON CENTER

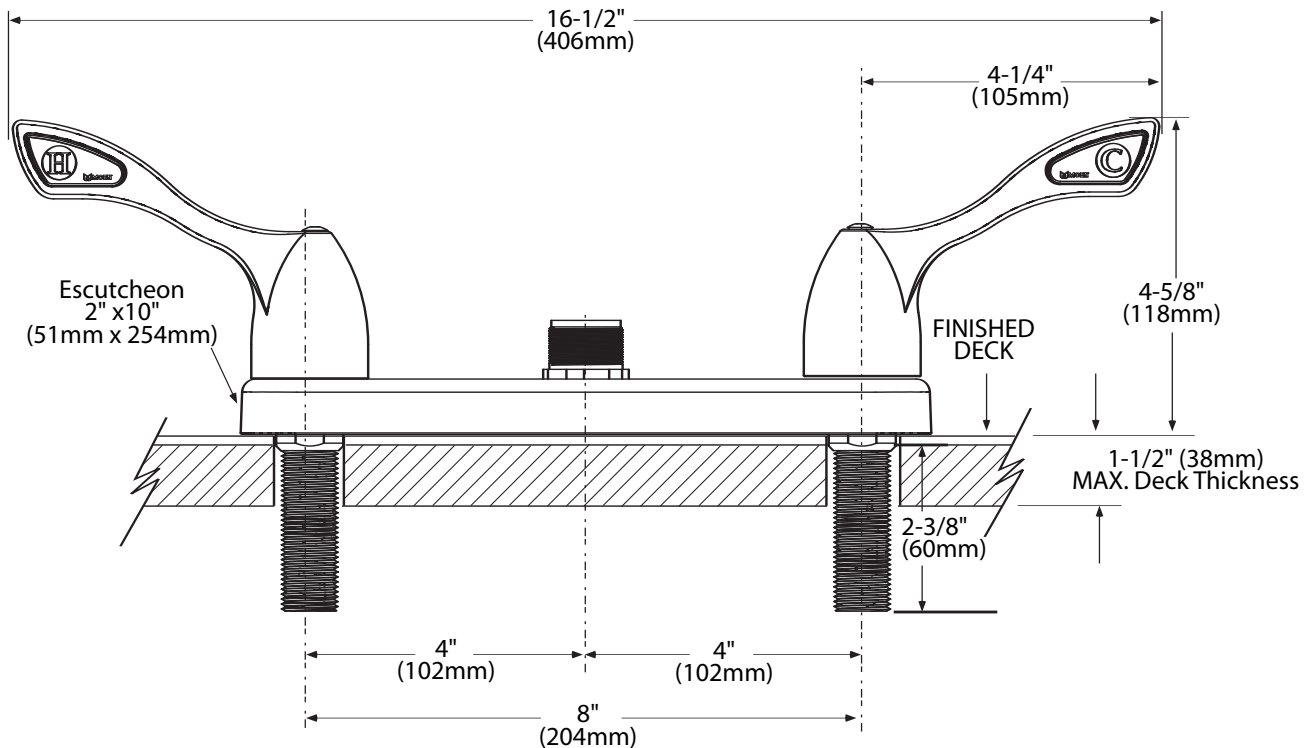

CRITICAL DIMENSIONS

(DO NOT SCALE)