

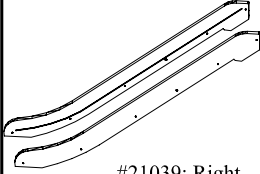

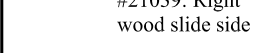

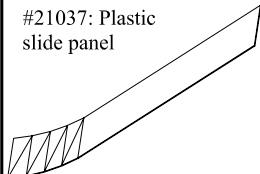
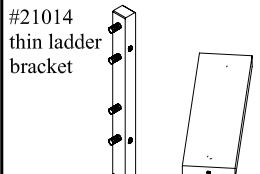

# ASSEMBLY INSTRUCTION

## #1880

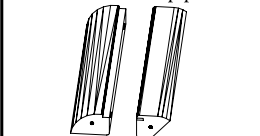
### Maxwood Furniture Inc.

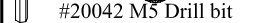
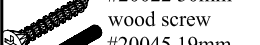
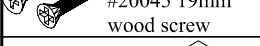
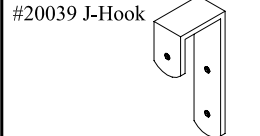
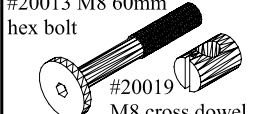
WWW.MAXTRIXKIDS.COM

| <b>#1880</b>   |                                    |
|--|------------------------------------|
| <p>#21038: Left wood slide side</p>  <p>#21039: Right wood slide side</p>  | <p>1 x #21038<br/>1 x #21039</p>   |
| <p>#21037: Plastic slide panel</p>    | <p>1 x #21037</p>                  |
| <p>#21014 thin ladder bracket</p>  <p>#21040 Slide panel support</p>  | <p>2 x #21014<br/>4 x #21040</p>   |
| <p>#21041: Slide stop piece</p>  <p>#21042: Slide lock piece</p>       | <p>1 x #21041<br/>1 x #21042</p>   |
| <p>#20018 Hex wrench 5mm</p>  <p>#20042 M5 Drill bit</p>               | <p>1 x #20018<br/>1 x #20042</p>   |
| <p>#20022 30mm wood screw</p>  <p>#20045 19mm wood screw</p>           | <p>2 x #20045<br/>4 x #20022</p>   |
| <p>#20039 J-Hook</p>   | <p>2 x #20039</p>                  |
| <p>#20013 M8 60mm hex bolt</p>  <p>#20019 M8 cross dowel</p>          | <p>12 x #20013<br/>12 x #20019</p> |

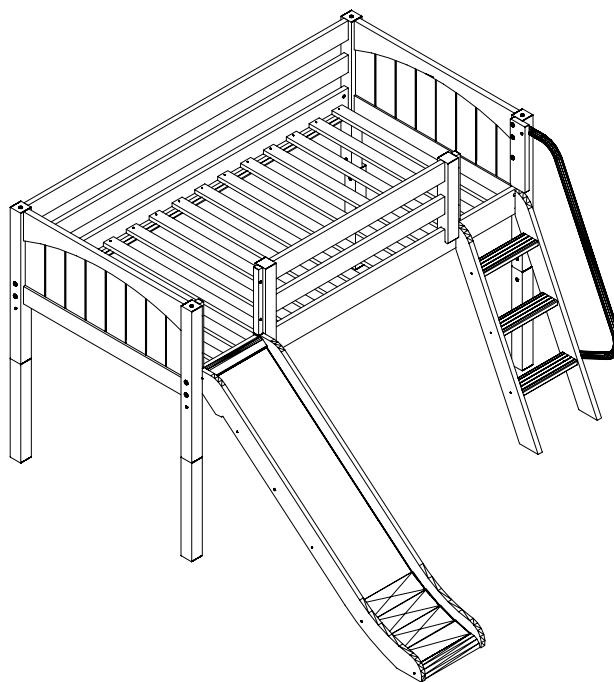
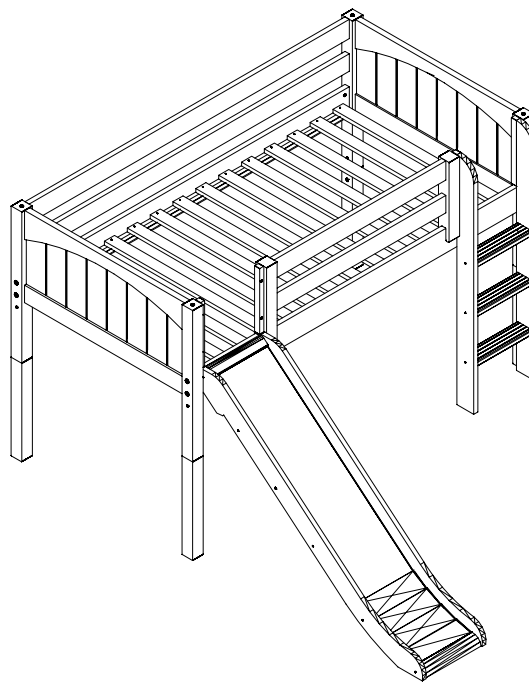

675 E. WASHINGTON AVE, BRIDGEPORT, CT 06608

1

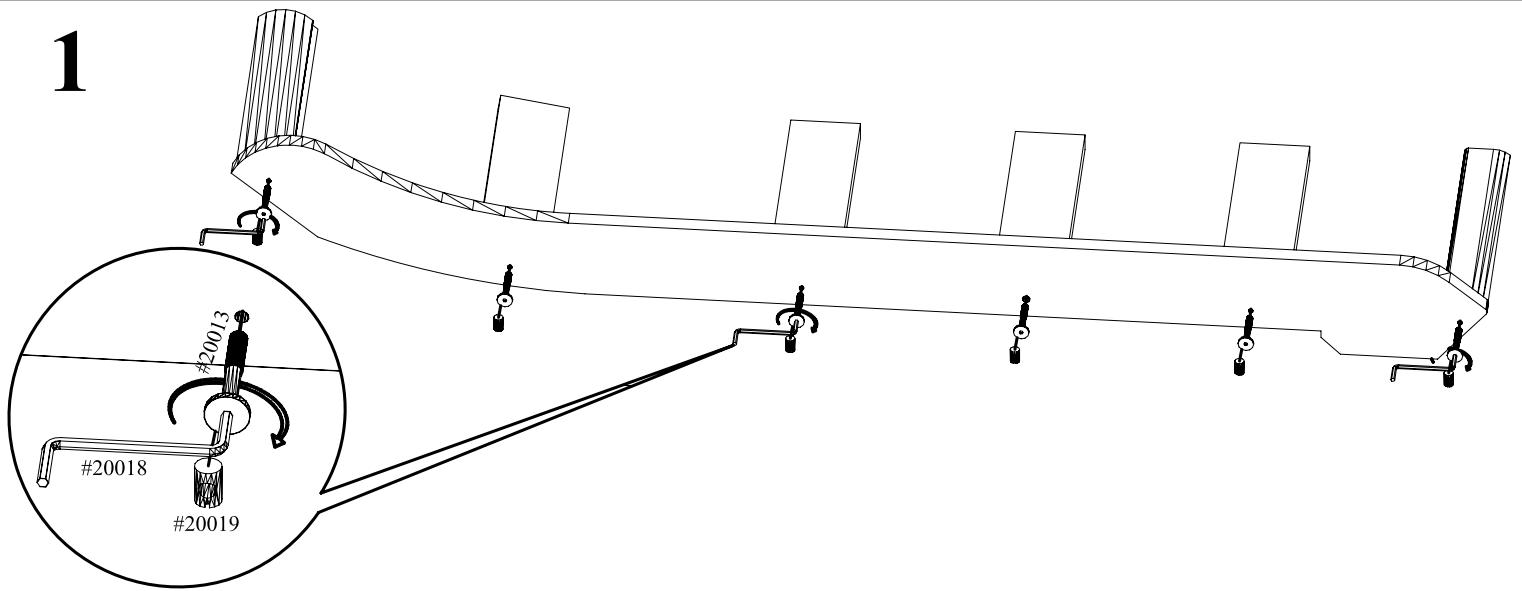

2

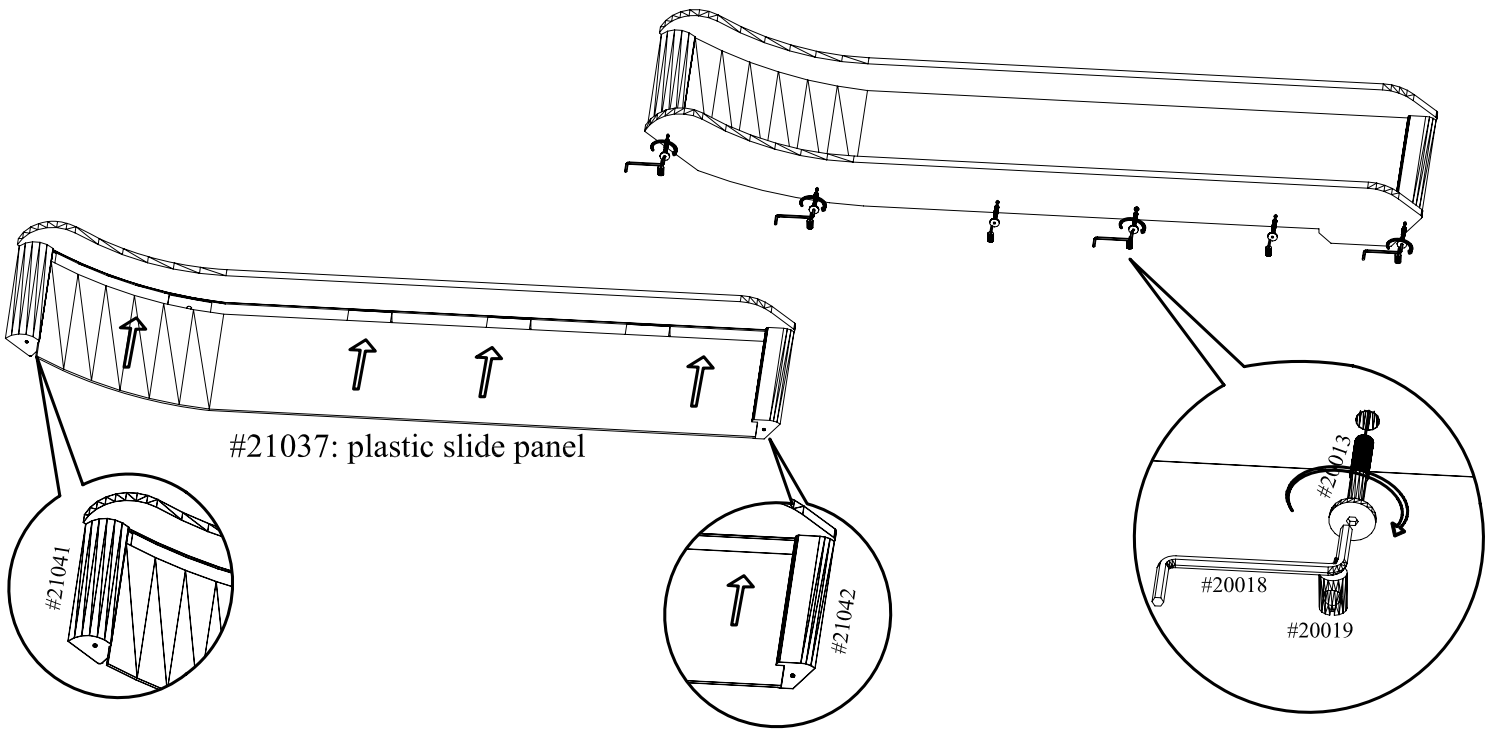

3

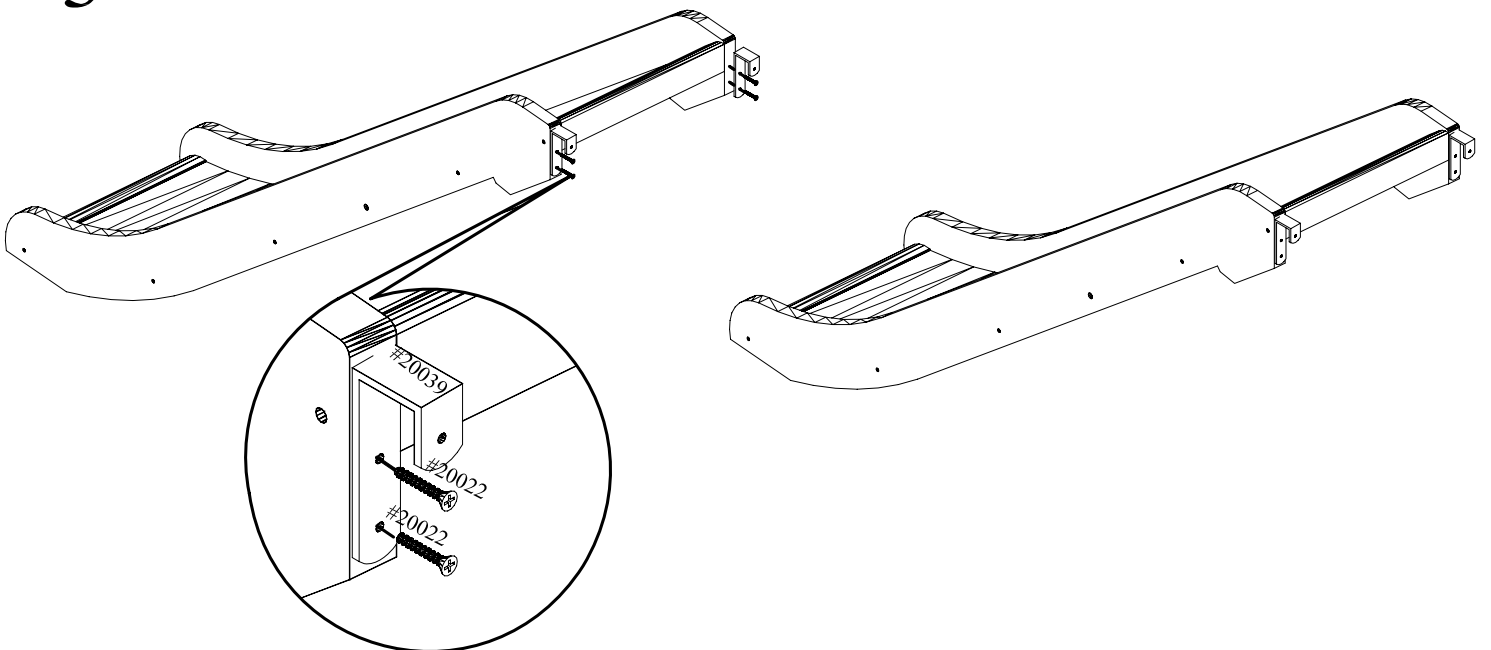

**Insert wooden plugs.**

When bed is completely assembled, you may proceed to plug up the holes in the bed.

The 7/16 inch (11mm) wood plugs go into the small holes on the top ½ inside face of the Bed End (if exposed) and unused hex bolt holes for side rails on the bottom 1/3 of the Bed End Legs.

The ¾ inch (17mm) wood plugs go into the cylinder barrel hole.

The 7/8 inch (23mm) wooden mushroom plugs go into the top hole of every Bed End leg (unless you have decided to purchase a finial pack).

**Size of mattress and Foundation:**

This bed is designed to use a mattress 74 inch – 75 inch (188cm – 190.5cm) long and 37½”-38½” (95.5cm – 97.5cm) wide with TWIN size; 74 inch – 75 inch (188cm – 190.5cm) long and 52½ inch – 53½ inch (133.5cm – 136cm) wide if FULL size. The total thickness of the mattress and foundation must not exceed 11 inches (28 cm).

**Note:** There must be at least 5 inches (12.7cm) from mattress sleeping surface to top edge of guard rail.

**Replacement Parts:**

Replacement Parts, including additional guard rails, may be obtained from any of our dealers.

**IMPORTANT:**

**ALWAYS REMEMBER TO CHECK AND TIGHTEN LOOSE BOLTS/HARDWARE EVERY MONTH, AS THESE MAY LOOSEN WITH USE OVER TIME.**

**THANK YOU FOR PURCHASING MAXTRIX™**

## **ENGLISH**

### **Size of Mattress and Foundation**

This bed is designed to use a mattress size 74"-75" long and 37½"-38½" wide with twin size; 52½"-53½" with full size. The total thickness must not exceed 11".  
Note: There must be at least 5" from mattress sleeping surface to top edge of guardrail.

## **SAFETY WARNINGS**

1. Follow the information on the warnings appearing on the upper bunk bed end structure and on the carton. Do not remove warning label from bed.
2. Always use recommended size mattress or mattress support, or both, to help prevent the likelihood of entrapment or falls.
3. Surface of mattress must be at least 5 in. below the upper edge of the guardrails.
4. Do not allow children 6 years of age to use the upper bunk.
5. Periodically check and ensure that the guardrail, ladder and other components are in their proper position, free from damage and that the connectors are tight.
6. Do not allow horseplay on or under the bed and prohibit jumping on the bed.
7. Prohibit more than one person on upper bunk.
8. Always use the ladder for entering and leaving the upper bunk.
9. Do not use substitute parts. Contact manufacturer or dealer for replacement parts.
10. Use of a night light may provide added safety precaution for a child using the upper bunk.
11. Always use guardrails on both long sides of upper bunk.
12. If the bunk bed will be placed next to a wall, the guardrail that runs the full length of the bed should be placed against the wall to prevent entrapment between the bed and the wall.
13. The use of water or sleep flotation mattresses is prohibited
14. Keep these instructions for future reference.

## **STRANGULATION HAZARD**

15. Never attach or hang items to any part of the bunk bed that are not designed for use with the bed, for example but not limited to hooks, belts, and jump ropes.

## **Replacement Parts**

Replacement parts, including additional guard rails, may be obtained from any of our Maxwood Furniture dealers.

## **FRANCAIS**

### **Dimension du Matelas et base de Lit**

Cet lit été conçu pour contenir un matelas de dimension 74-75 pouces de long et 37½-38½ pouces de large avec "twin" taille; 52½-53½ pouces de large avec "full" taille. L'épaisseur totale de doit pas excéder 11 pouces.  
Note: Il doit y avoir une distance d'au moins 5 pouces entre la surface du matelas et la partie supérieure de la barrière de sécurité.

## **AVERTISSEMENT**

1. Suivre les indications apparaissant sur la partie Supérieure du lit superposé ainsi que sur le carton. Ne pas enlever les indications au lit.
2. Toujours utiliser la dimension du matelas et/ou du sommier recommandée afin de réduire les probabilités de blessures.
3. La surface du matelas doit être d'au moins 5 pouces en-dessous de la partie supérieure de la barrière de sécurité.
4. Interdire l'utilisation du lit supérieur aux enfants de moins de 6 ans.
5. Vérifier et s'assurer périodiquement que la barrière de sécurité, l'échelle et les autres pièces sont à leur position respective, à l'abri des dommages, et que les raccords sont solides.
6. Ne pas autoriser le chahut sur et en-dessous du lit et interdiction de sauter sur le lit.
7. Interdire plus d'une personne sur le lit supérieur.
8. Toujours utiliser l'échelle pour monter et descendre du lit.
9. Ne pas utiliser de substitut de pièces. Contacter le manufacturier ou détaillant pour le remplacement des pièces.
10. Pour une sécurité additionnelle de l'enfant, l'utilisation d'une veilleuse est recommandée.
11. Toujours utiliser les barrières de sécurité le long des deux côtés du lit supérieur.
12. Si le lit est positionné près du mur, la barrière de sécurité pleine longueur doit être placée entre le mur et le lit afin d'éviter à l'enfant d'être pris au piège.
13. L'utilisation de matelas ou lit d'eau est interdit.
14. Conserver ces instructions pour référence future.

## **RISQUE D'ÉTRANGLEMENT**

N'attachez jamais ou accrochez les articles à n'importe quelle partie du lit de couchette qui ne sont pas conçus pour l'usage avec le lit, par exemple mais non limité aux crochets, aux ceintures, et aux cordes de saut.

## **Pièces de remplacement**

Les pièces de remplacement, incluant les barrières de sécurité additionnelles, sont disponibles dans tous les détaillants Maxwood Furniture.