

AURORA Swing 120

Designer
Ettore Cimini - 2005

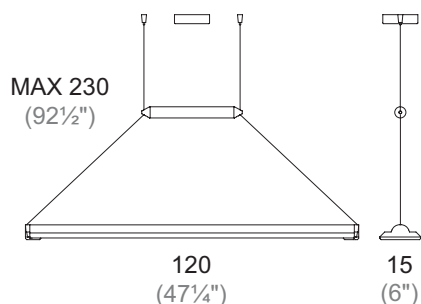



Apparecchio di illuminazione a sospensione in alluminio pressofuso sostenente un vetro opportunamente sagomato e lavorato per diffondere la luce di una lampadina fluorescente lineare tipo T5 da 54W.

Suspension light fitting consisting of a frame of brushed die-cast aluminium, holding a straight glass of optic quality carefully machined and polished in order to diffuse the light of a fluorescent tube T5 54W.

Haengeleuchte aus Pressgussaluminium mit Struktur aus Stahl, die ein besonders geformtes Glas hält, das speziell für die Diffusion der Lichtstrahlen einer Leuchtstofflampe linear Typ T5 von 54W bearbeitet wurde.



Col. 34
Spazzolato zaponato
Brushed
Gebürstet

Denominazione - Name - Name	Aurora Swing 120 (cod. 525)
Certificazioni - Certificated - Prüfzeichen	
Normative - Norms - Normen	EN 60-598 (CEI 34-21)
Lampadina - Light sources - Leuchtmittel	54W FL - G5
Versioni - Available - Versionen	230V (Europe) - 110V (USA - Japan) - 240V (England)
Classe di isolamento - Insulation Class - Isolierungsklasse	I
Classe di protezione - Protection Class - Protektionsgrad	IP20
Imballo - Packaging - Verpackung	 0,046m ³ - 8,300Kg

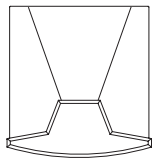

Cod. 520
Aurora Parete 20

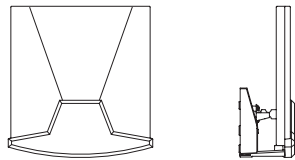

Cod. 521
Aurora Parete 20 L

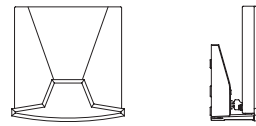

Cod. 523
Aurora Parete 14

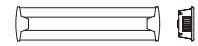

Cod. 534
Aurora Flat 60

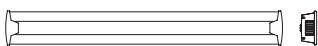

Cod. 535
Aurora Flat 120

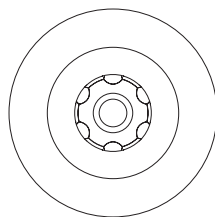

Cod. 540
Aurora Circle 30 P

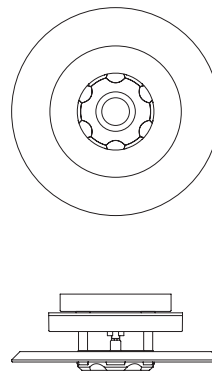

Cod. 541
Aurora Circle 30 S

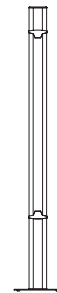

Cod. 550
Aurora Tower 180

Notes
