



LINON HOME DÉCOR PRODUCTS INC.

ASSEMBLY INSTRUCTIONS

MODEL: 14010BLKIV-01-KD

TRENTO LOVESEAT

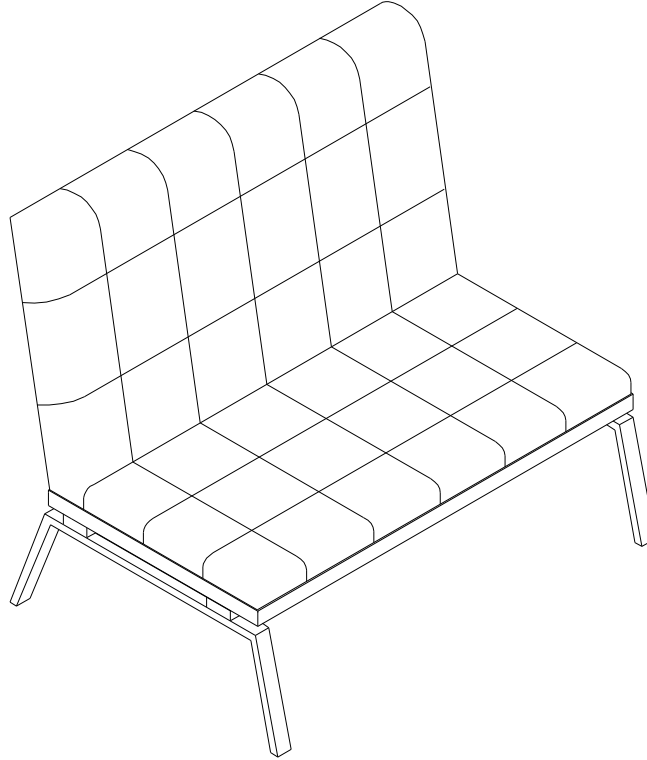

We are here to help!

We try to insure that your furniture is received in excellent condition. Our customer service representatives are ready to help you with quick and efficient service if a part is damaged, missing, if you have questions or require assembly assistance.

To avoid any inconvenience, please call Linon Customer Service prior to returning the item to the store.

Our office is open Monday –Friday 9:00 AM to 5:00 PM. Eastern Standard Time.

Toll free number: 1-800-262-1852 Customer Service

Fax: 1-516-699-1001

Telephone: 1-516-699-1000

E-mail: consumersupport@linon.com

For care instruction for your newly purchased furniture, please visit our web site www.linon.com.



LINON HOME DÉCOR PRODUCTS INC.

ASSEMBLY INSTRUCTIONS

PARTS LIST

A: BACK CUSHION B: SEAT CUSHION C: LEFT FRAME D: RIGHT FRAME
 E: LARGE SUPPORT POST F: SMALL SUPPORT POST G: METAL RAIL

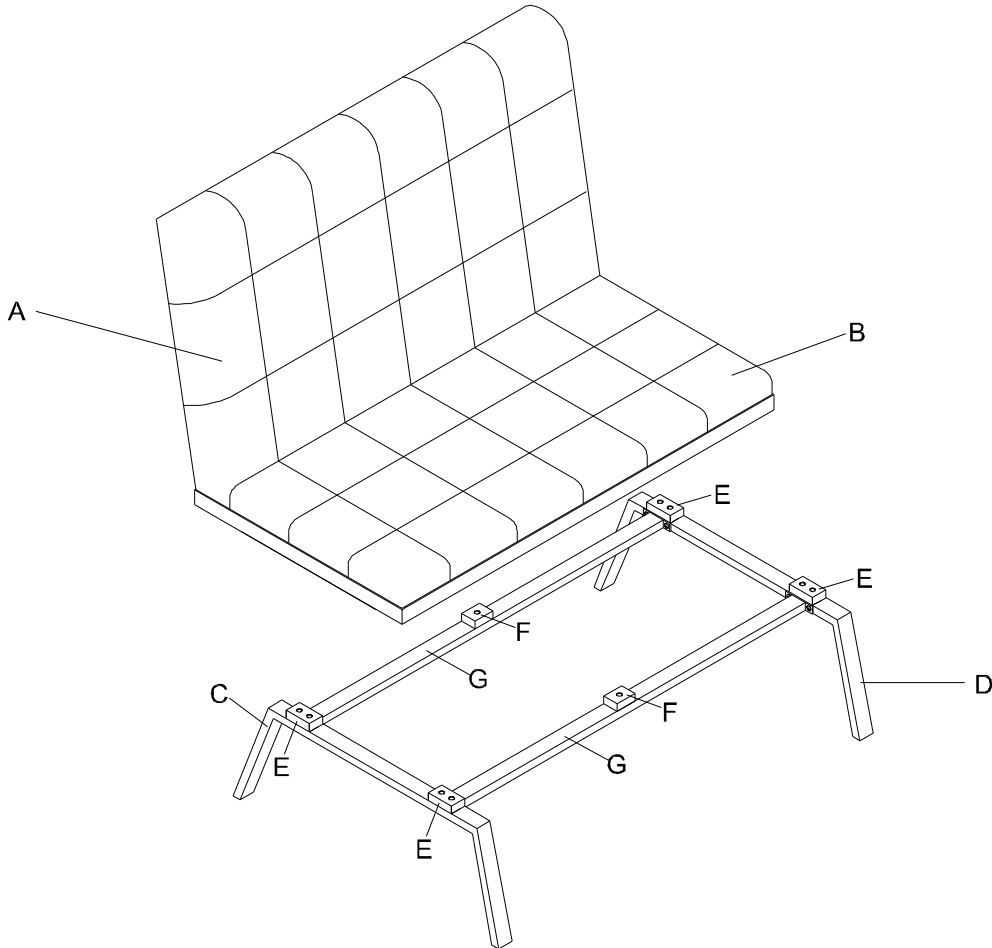

HARDWARE LIST

PARTS	GRAPHICS	DESCRIPTION	SIZE	QUANTITY
H		SHORT BOLT	1/2"	8
I		MIDDLE BOLT	1-1/2"	3
J		LONG BOLT	3"	10
K		FLAT WASHER	1/4"	13
L		SPRING WASHER	1/4"	13
M		SMALL ALLEN WRENCH	1/4"	1
N		LARGE BOLT	3"	6
O		LARGE FLAT WASHER	5/16"	6
P		LARGE SPRING WASHER	5/16"	6
Q		LARGE ALLEN WRENCH	5/16"	1



LINON HOME DÉCOR PRODUCTS INC.

ASSEMBLY INSTRUCTIONS

PREPARATION:

SELECT A WORK SURFACE. WE RECOMMEND A TABLE TOP. PLEASE PROTECT IT VERY WELL, INCLUDING THE EDGES TO PREVENT ANY DAMAGES; YOU MAY USE A BLANKET AND THE CARDBOARD FROM THE BOX.

STEP-1: CONNECT THE METAL RAILS-G TO LEFT AND RIGHT FRAMES (C & D) AS SHOWN IN FIGURE-1

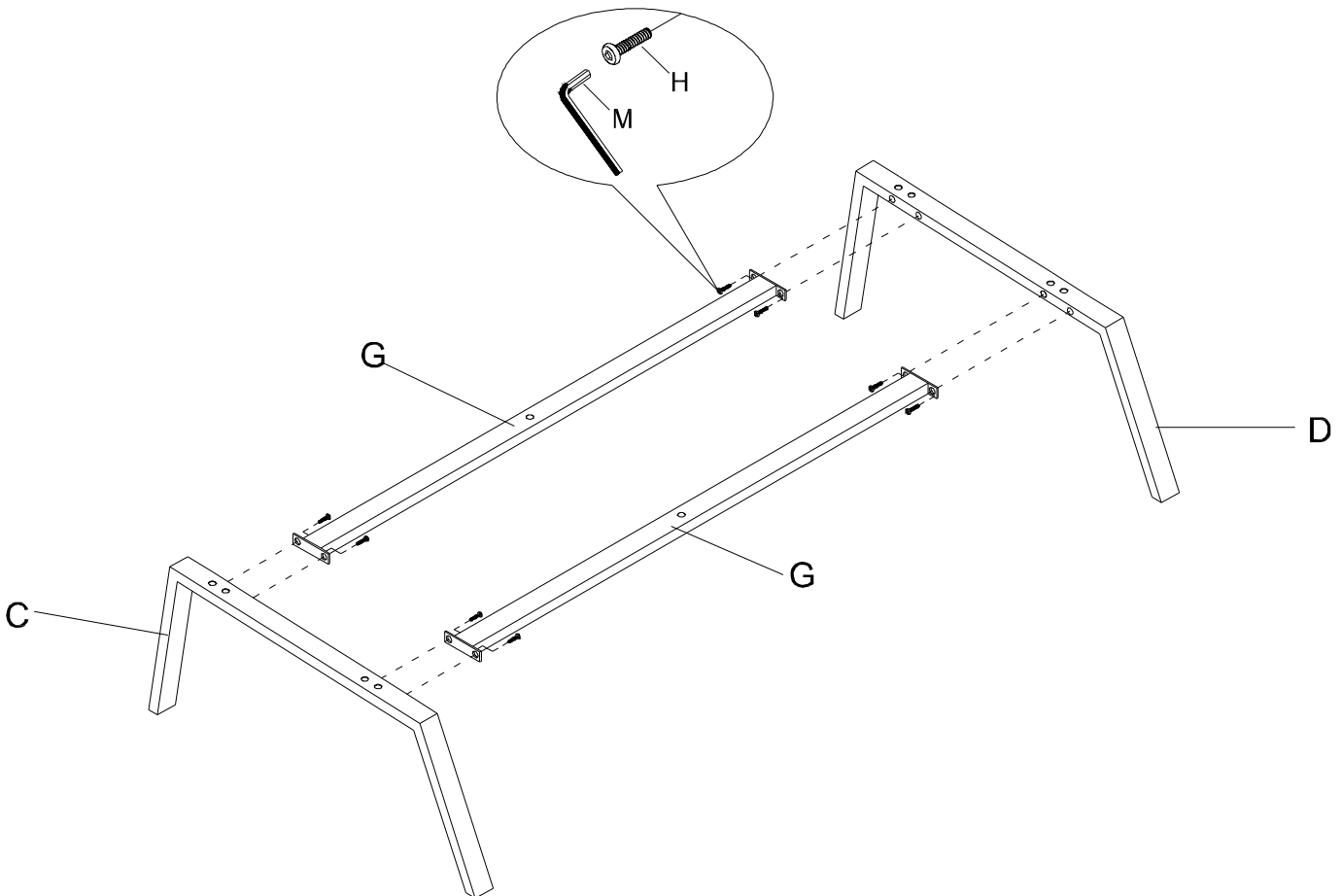

FIGURE-1

- 1.1 POSITION LEFT FRAME -C AND RIGHT FRAME-D ON THE WORK SURFACE AS SHOWN IN FIGURE-1.
- 1.2 PLACE THE TWO METAL RAILS-G ONTO THE LEFT FRAME-C AND RIGHT FRAME-D.
- 1.3 INSERT ONE SHORT BOLT-H THROUGH ANY OF THE TWO HOLES IN THE END OF THE METAL RAIL ADJACENT TO THE SIDE FRAMES; IF NECESSARY, MOVE THE SHORT BOLT-H AROUND TO FIND THE HOLE IN THE LEFT AND RIGHT FRAMES. TIGHTEN BY HAND.
- 1.4 REPEAT PROCEDURE 1.3 TO INSTALL THE REMAINING SEVEN SHORT BOLTS-H.
- 1.5 FULLY TIGHTEN BOLTS USING SMALL ALLEN WRECH-M.



LINON HOME DÉCOR PRODUCTS INC.

ASSEMBLY INSTRUCTIONS

STEP-2: CONNECT BACK CUSHION-A TO SEAT CUSHION-B AS SHOWN IN FIGURE-2

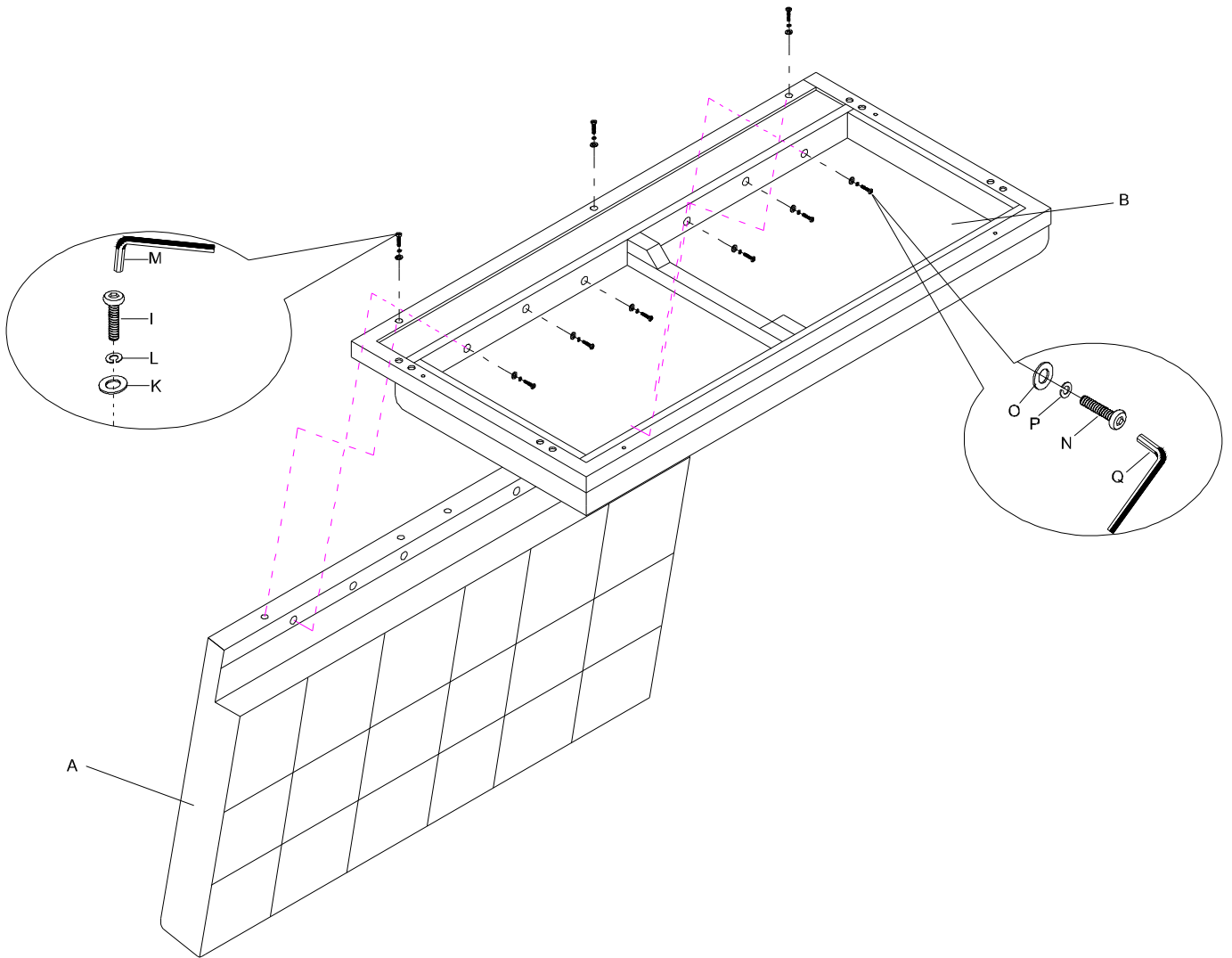

FIGURE-2

- 2.1 POSITION BACK CUSHION-A ON THE WORK SURFACE AS SHOWN IN FIGURE-2.
- 2.2 PLACE THE SEAT CUSHION-B ONTO BACK CUSHION-A.
- 2.3 INSERT ONE LARGE SPRING WASHER-P, THEN ONE LARGE FLAT WASHER-O OVER ONE LARGE BOLT-N; INSERT THE LARGE BOLT-N THROUGH ANY OF THE SIX HOLES IN THE CENTER OF THE SEAT CUSHION-B; IF NECESSARY, MOVE THE LARGE BOLT-N AROUND TO FIND THE HOLE IN THE BACK CUSHION. TIGHTEN BY HAND.
- 2.4 REPEAT PROCEDURE 2.3 TO INSTALL THE REMAINING FIVE SETS N+P+O.
- 2.5 REPEAT PROCEDURE 2.4 TO INSTALL THREE MIDDLE BOLTS WITH HARDWARE I+K+L, TO SECURE SEAT CUSHION-B TO BACK CUSHION-A.



LINON HOME DÉCOR PRODUCTS INC.

ASSEMBLY INSTRUCTIONS

STEP-3: CONNECT THE ASSEMBLED TOP UNIT TO THE ASSEMBLED BASE UNIT AS SHOWN IN FIGURE-5

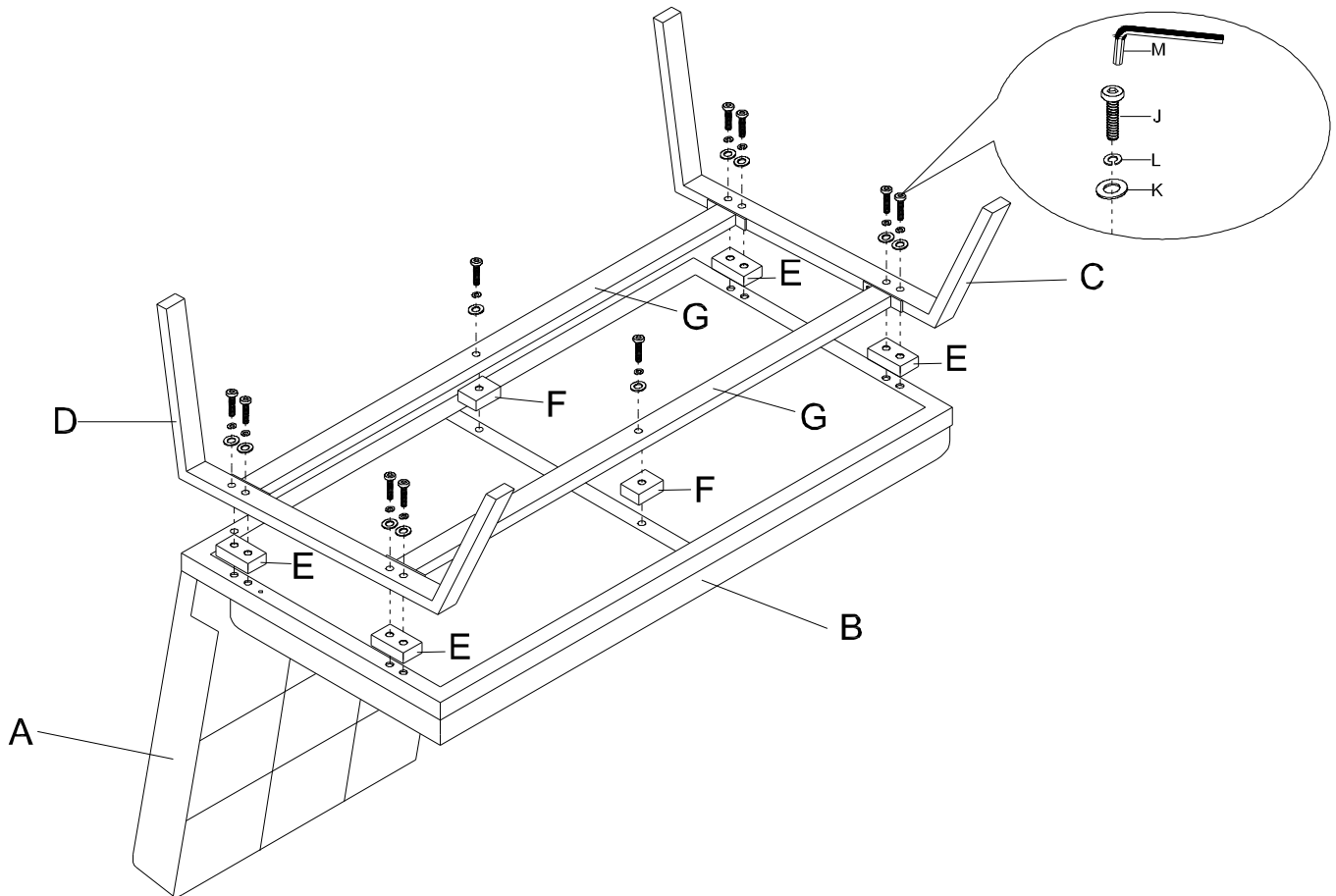

FIGURE-3

- 3.1 POSITION THE ASSEMBLED UNIT ON THE WORK SURFACE AS SHOWN IN FIGURE-3.
- 3.2 PLACE THE FOUR LARGE SUPPORT POSTS-E AND TWO SMALL SUPPORT POST-F ONTO SEAT CUSHION AS SHOWN.
- 3.3 PLACE THE ASSEMBLED TOP UNIT ON TO THE SUPPORT POSTS AS SHOWN .
- 3.4 INSERT ONE SPRING WASHER-L, THEN ONE FLAT WASHER-K OVER ONE LONG BOLT-J; INSERT THE BOLT-J THROUGH ANY OF THE TWO HOLES IN THE CORNER OF THE SIDE FRAME ADJACENT TO THE LEGS; IF NECESSARY, MOVE THE LONG BOLT-J AROUND TO FIND THE HOLE IN THE SUPPORT POST AND SEAT CUSHION. TIGHTEN BY HAND.
- 3.5 REPEAT PROCEDURE 3.4 TO INSTALL THE REMAINING NINE SETS J+L+K.
- 3.6 FULLY TIGHTEN BOLTS USING SMALL ALLEN WRENCH-M.
- 3.7 TURN THE LOVESET UPRIGHT.



LINON HOME DÉCOR PRODUCTS INC.

ASSEMBLY INSTRUCTIONS

LINON LIMITED MANUFACTURER'S

WARRANTY

This product is covered under our manufacturer's limited warranty (Linon Home Décor Products). This ensures that under this warranty the Linon item:

Will be free from defects in material and workmanship when purchased and that for a period of 30 days from date of purchase we will replace any missing part and for a period of six months from date of purchase we will replace any defects in the product that occur during normal use. At that point it will be at the option of Linon to replace the defective part or refer you back to the original purchase site.

The warranty does not cover any labor and or freight charges to or from the service center. It does not cover furniture used for commercial purposes, failures caused by improper care, unreasonable or abusive use, freeze damage or acts of God.

All purchase must be made in authorized dealerships during the normal course of business. Proof of purchase may be required.

Service

For further information please contact our customer service department between the hours of 9:00 AM and 5:00 PM Eastern Standard Time. You can contact us at:

Linon Home Décor Products
22 Jericho Turnpike
Mineola, NY 11501

E-Mail: consumersupport@linon.com

Tel: 516-699-1000

Fax: 516-699-1001

TOLL FREE: 1-200-262-1852