

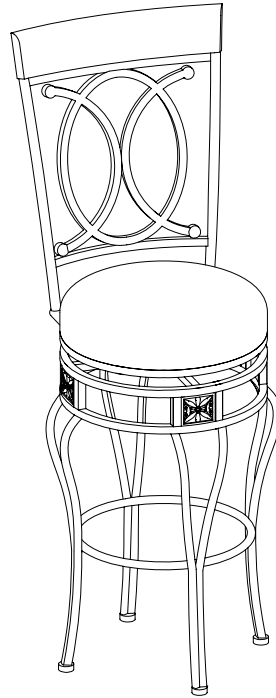

LINON HOME DÉCOR PRODUCTS INC.

ASSEMBLY INSTRUCTIONS

MODEL:02564MTL-01-KD-U
24" O-X BACK METAL SWIVEL STOOL



We are here to help!

We try to insure that your furniture is received in excellent condition. Our customer service representatives are ready to help you with quick and efficient service if a part is damaged, missing, if you have questions or require assembly assistance.

To avoid any inconvenience, please call Linon Customer Service prior to returning the item to the store.

Our office is open Monday –Friday 9:00 AM to 5:00 PM. Eastern Standard Time.

Toll free number: 1-800-262-1852 Customer Service

Fax: 1-516-699-1001

Telephone: 1-516-699-1000

E-mail: consumersupport@linon.com

For care instruction for your newly purchased furniture, please visit our web site www.linon.com



LINON HOME DÉCOR PRODUCTS INC.

#1-Bottom frame #2-Top frame #3-Cushion

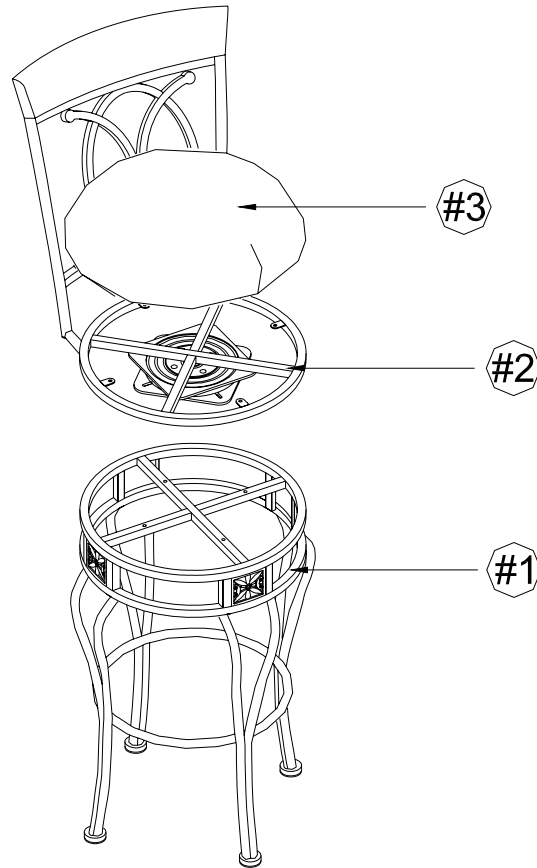

HARDWARE



PART	GRAPHIC	DESCRIPTION	QUANTITY
A		ALLEN SCREW	4
B		SPRING WASHER	4
C		FLAT WASHER	4
D		SCREW	4
E		HEX WRENCH	1



FIG.1

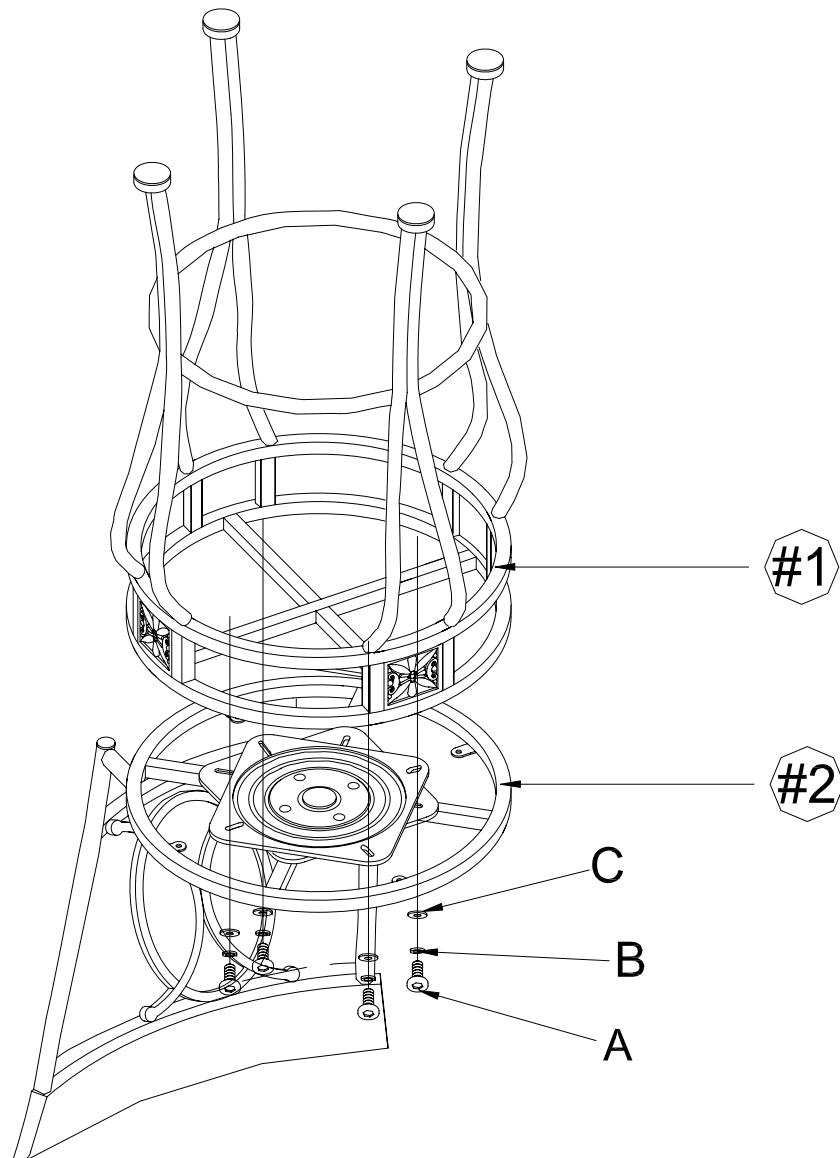

(1) PLACE THE TOP FRAME (#2) UP-SIDE-DOWN ON THE CARPET AS SHOWN FIG,1 FOR EASY ASSEMBLY

(2) ALIGN THE HOLES OF SWIVEL PLATE WITH THE HOLES OF BOTTOM FRAME (#1) AS SHOWN FIG.1, USING ALLEN SCREW (A),SPRING WASHER (B),FLAT WASHER(C) TO ASSEMBLE TOGETHER.FIRMLY TIGHTEN WITH HEX WRENCH (E)

NOTE: PLEASE DO NOT TIGHTEN EACH SCREW UNTIL ALL SCREWS ARE LINED UP WITH THE FRAME.



FIG.2

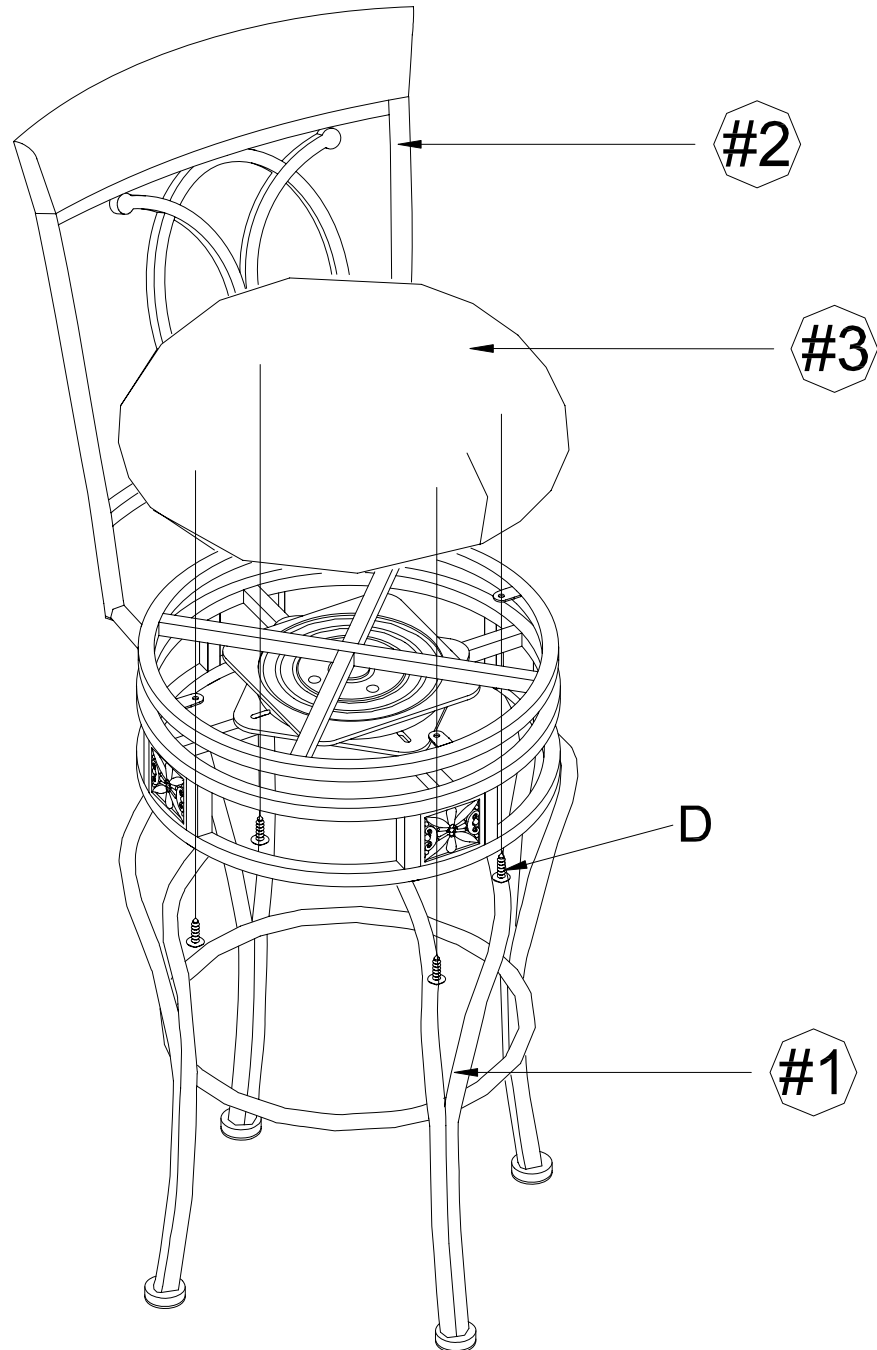

(3) PLACE THE UNIT UPRIGHT AS SHOWN FIG.2, AND FASTEN THE CUSHION (#3) WITH SCREW (D) AND PHILLIPS HEAD SCREW DRIVER (NOT PROVIDED) AS SHOWN FIG.2.



LINON HOME DÉCOR PRODUCTS INC.

LINON LIMITED MANUFACTURER'S WARRANTY

This product is covered under our manufacturer's limited warranty (Linon Home Décor Products). This ensures that under this warranty the Linon item:

Will be free from defects in material and workmanship when purchased and that for a period of 30 days from date of purchase we will replace any missing part and for a period of six months from date of purchase we will replace any defects in the product that occur during normal use. At that point it will be at the option of Linon to replace the defective part or refer you back to the original purchase site.

The warranty does not cover any labor and or freight charges to or from the service center. It does not cover furniture used for commercial purposes, failures caused by improper care, unreasonable or abusive use, freeze damage or acts of God.

All purchase must be made in authorized dealerships during the normal course of business. Proof of purchase may be required.

Service

For further information please contact our customer service department between the hours of 9:00 AM and 5:00 PM Eastern Standard Time. You can contact us at:

Linon Home Décor Products
22 Jericho Turnpike
Mineola, NY 11501

E-Mail: consumersupport@linon.com

Tel: 516-699-1000

Fax: 516-699-1001

Toll Free: 1-800-262-1852