



LINON HOME DECOR PRODUCTS, INC.

ASSEMBLY INSTRUCTIONS

MILANO BAR 30 DK BROWN DECO LEATHER

0211VBRN121-01-KD

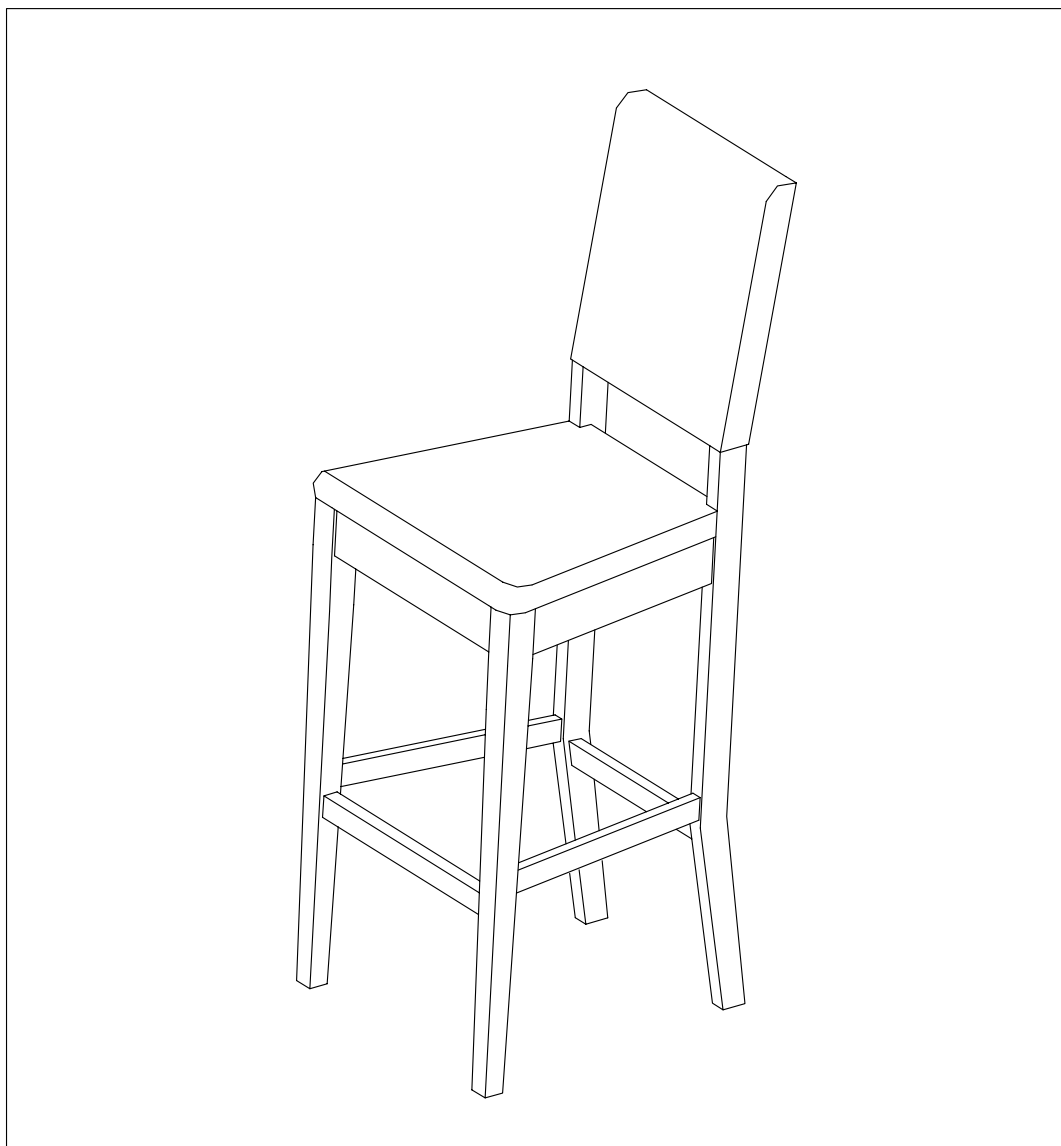

We are here to help!

We try to insure that your furniture arrives in excellent condition.

Our customer service representatives are ready to help you with quick, efficient service if a part is damaged or missing and if you have questions or require assembly assistance.

To avoid any inconvenience, please call Linon Customer Service prior to returning the item to the store.

Our office is open Monday - Friday 9:00 AM to 5:00 PM, Eastern Standard Time.

Toll free number : 1 - 800 - 262 - 1852 Customer Service

Fax : (516) 699-1001

Telephone : (516) 699 - 1000

For care instructions on your newly purchased furniture, please visit our web site www.linon.com



LINON HOME DECOR PRODUCTS, INC.

Parts Identification

ITEM	DESCRIPTION	QTY
1A	SEAT	01
1B	ASSEMBLED BACK FRAME	01
2D	RIGHT RAIL	01
2E	LEFT RAIL	01
3C	ASSEMBLED FRONT FRAME	01

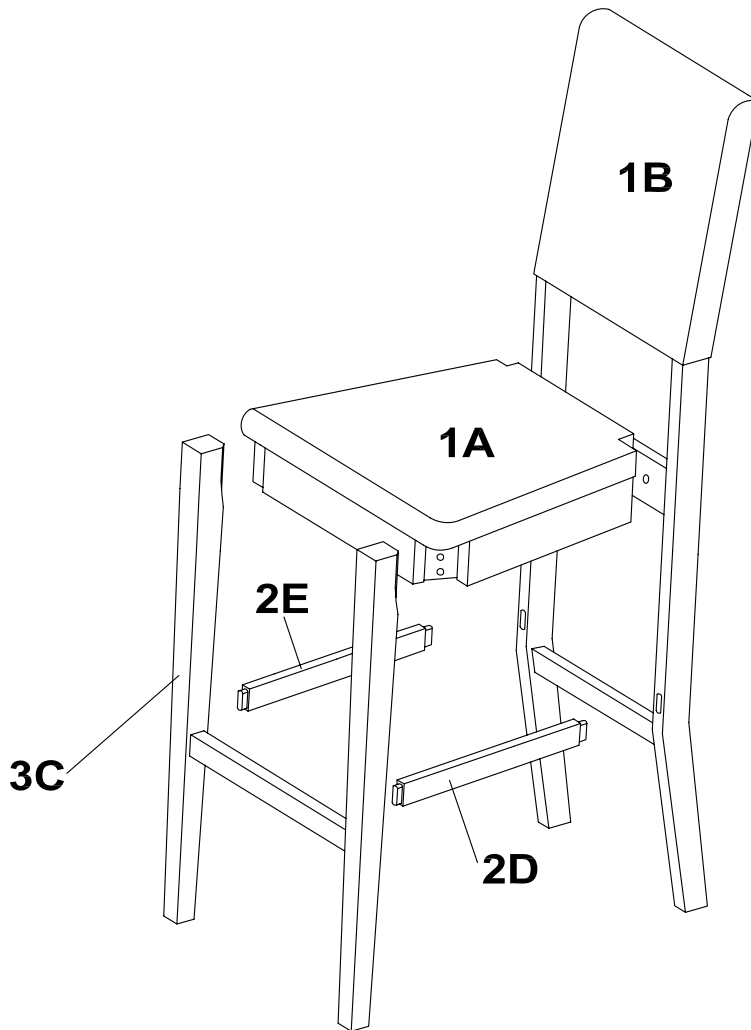

For ease of identification all parts are labeled to correspond to the Step number in which the part is used.

If any **parts** are MISSING or DAMAGED in this package, circle the item (**s**) needed on the parts list. Print your name, address and phone number in the area below and mail to LINON HOME DÉCOR PRODUCTS, INC.:

22 Jericho Turnpike, Mineola NY 11501 or call 1-800-262-1852.(TOLL FREE)

You can also email us at consumersupport@linon.com or fax to (516)699-1001



LINON HOME DECOR PRODUCTS, INC.

Hardware Identification

ITEM	DESCRIPTION	QTY
A	LONG BOLT	04
B	MEDIUM BOLT	04
C	SHORT BOLT	02
D	WOOD SCREW	04
E	FLAT WASHER	10
F	SPRING WASHER	10
G	ADHESIVE FELT PAD	04
H	HEXAGONAL WRENCH	01

A

LONG BOLT
= 4 pcs

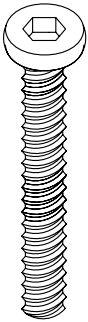
**B**

MEDIUM BOLT
= 4 pcs

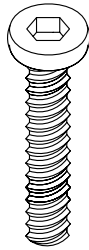
**C**

SHORT BOLT
= 2 pcs

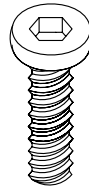
**D**

WOOD SCREW
= 4 pcs

**E**

FLAT WASHER
= 10 pcs

**F**

SPRING WASHER
= 10 pcs

**G**

ADHESIVE FELT PAD
= 4 pcs

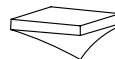
**H**

HEXAGONAL WRENCH
= 1 pc

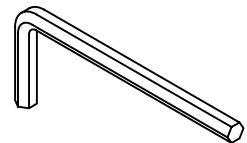

If any **parts** are MISSING or DAMAGED in this package, circle the item (**s**) needed on the parts list. Print your name, address and phone number in the area below and mail to LINON HOME DÉCOR PRODUCTS, INC.: 22 Jericho Turnpike, Mineola NY 11501 or call 1-800-262-1852.(TOLL FREE) You can also email us at consumersupport@linon.com or fax to (516)699-1001



LINON HOME DECOR PRODUCTS, INC.

PREPARATION:

SELECT A WORK SURFACE. WE RECOMMEND A TABLE TOP. PLEASE PROTECT IT VERY WELL, INCLUDING THE EDGES TO PREVENT ANY DAMAGES; YOU MAY USE A BLANKET AND THE CARDBOARD FROM THE CARTON BOX.

STEP 1: CONNECT THE SEAT- 1A TO ASSEMBLED BACK FRAME- 1B AS SHOWN IN FIGURE-1

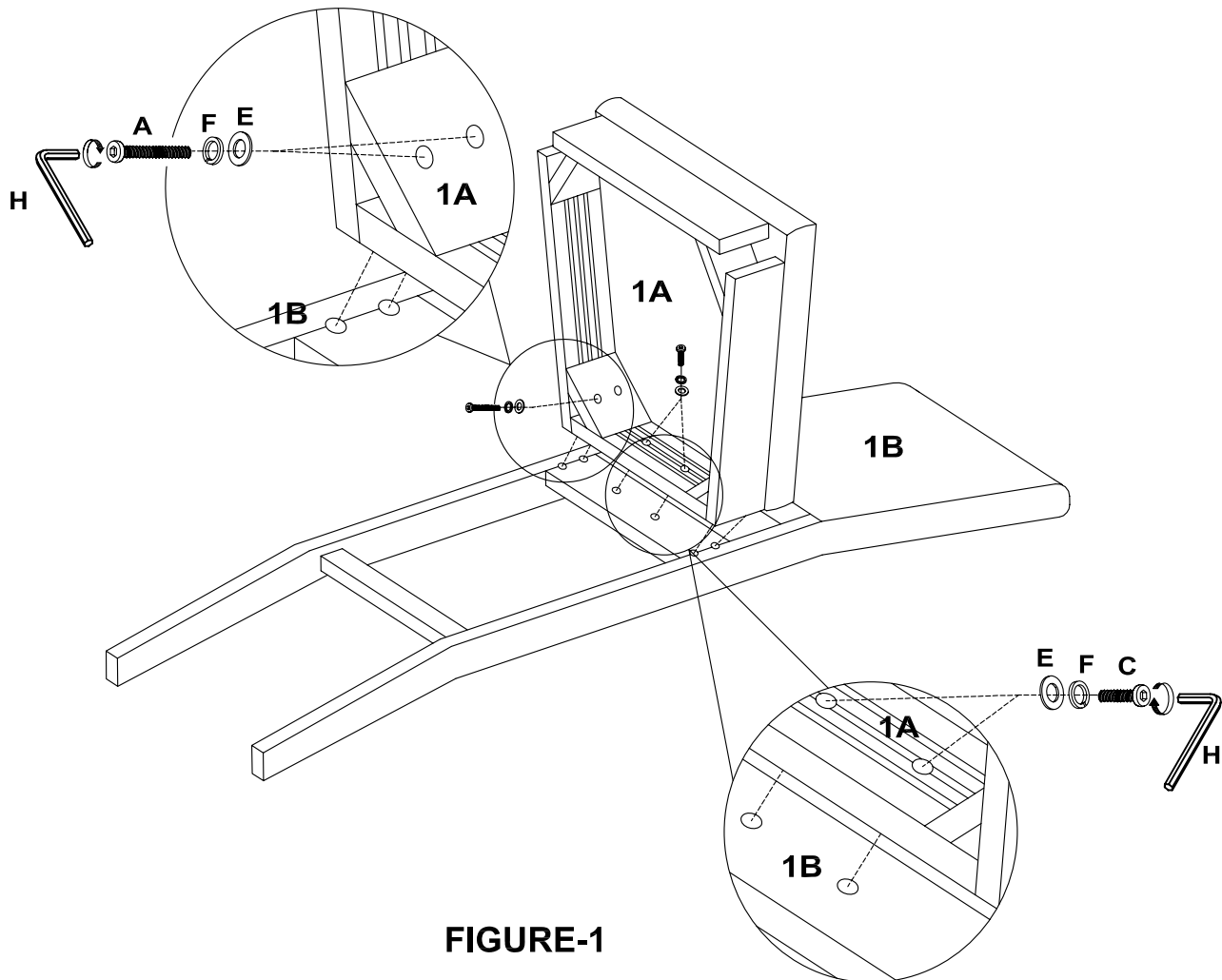

FIGURE-1

- 1.1 POSITION BACK (1B) ON THE WORK SURFACE AS SHOWN IN FIGURE-1
- 1.2 LOOK FOR TWO WOODEN DOWELS OUTSIDE SEAT (1A); INSERT THEM INTO THE CORRESPONDING HOLES BACK (1B)
- 1.3 INSERT (01) SPRING WASHER (F) THEN (01) FLAT WASHER (E) OVER (01) LONG SCREW (A); INSERT THE SCREW (A) THROUGH ANY OF THE FOUR HOLES IN THE CORNER BRACKETS ADJACENT TO THE BACK LEGS.; IF NECESSARY, MOVE THE SCREW (A) AROUND TO FIND THE HOLE IN THE BACK LEG. TIGHTEN BY HAND ONLY.
- 1.4 REPEAT PROCEDURE 1.3 TO INSTALL THE REMAINING THREE SETS A+F+E.
- 1.5 REPEAT PROCEDURE 1.4 TO INSTALL (02) SHORT SCREWS (C) WITH HARDWARE C+F+E TO SECURE SEAT (1A) TO BACK (1B).



LINON HOME DECOR PRODUCTS, INC.

STEP 2: CONNECT THE RIGHT RAIL- 2D AND LEFT RAIL- 2E TO ASSEMBLED BACK FRAME - 1B AS SHOWN IN FIGURE-2

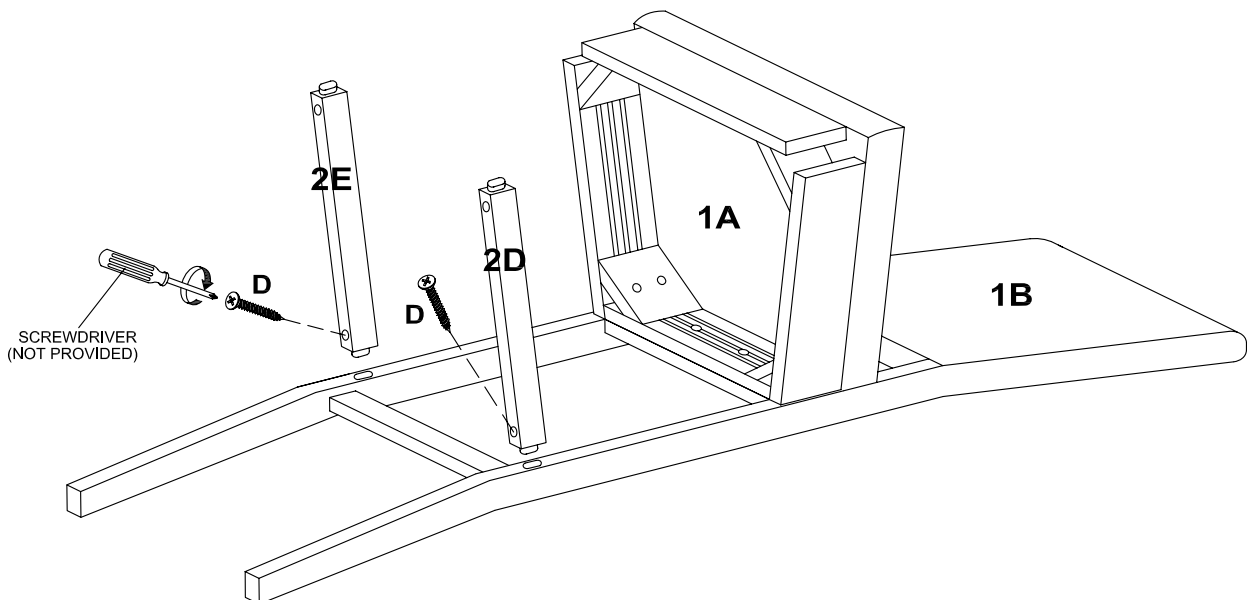

FIGURE-2

2.1 FOLLOW THE LABELS ON RAILS (2D) AND (2E). AND INSERT THEM IN THE BACK LEGS AS SHOWN. SECURE CONNECTION WITH (02) WOOD SCREWS (D).



LINON HOME DECOR PRODUCTS, INC.

STEP 3: CONNECT THE ASSEMBLED FRONT FRAME- 3C TO SEAT- 1A AND RAILS- 2D/2E AS SHOWN IN FIGURE-3A/B

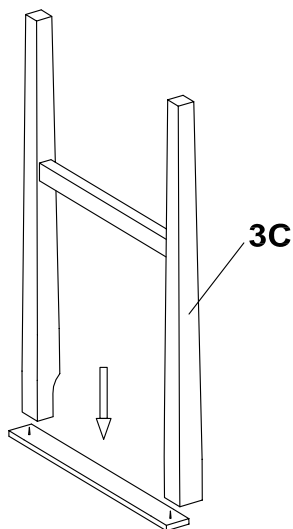

FIGURE-3A

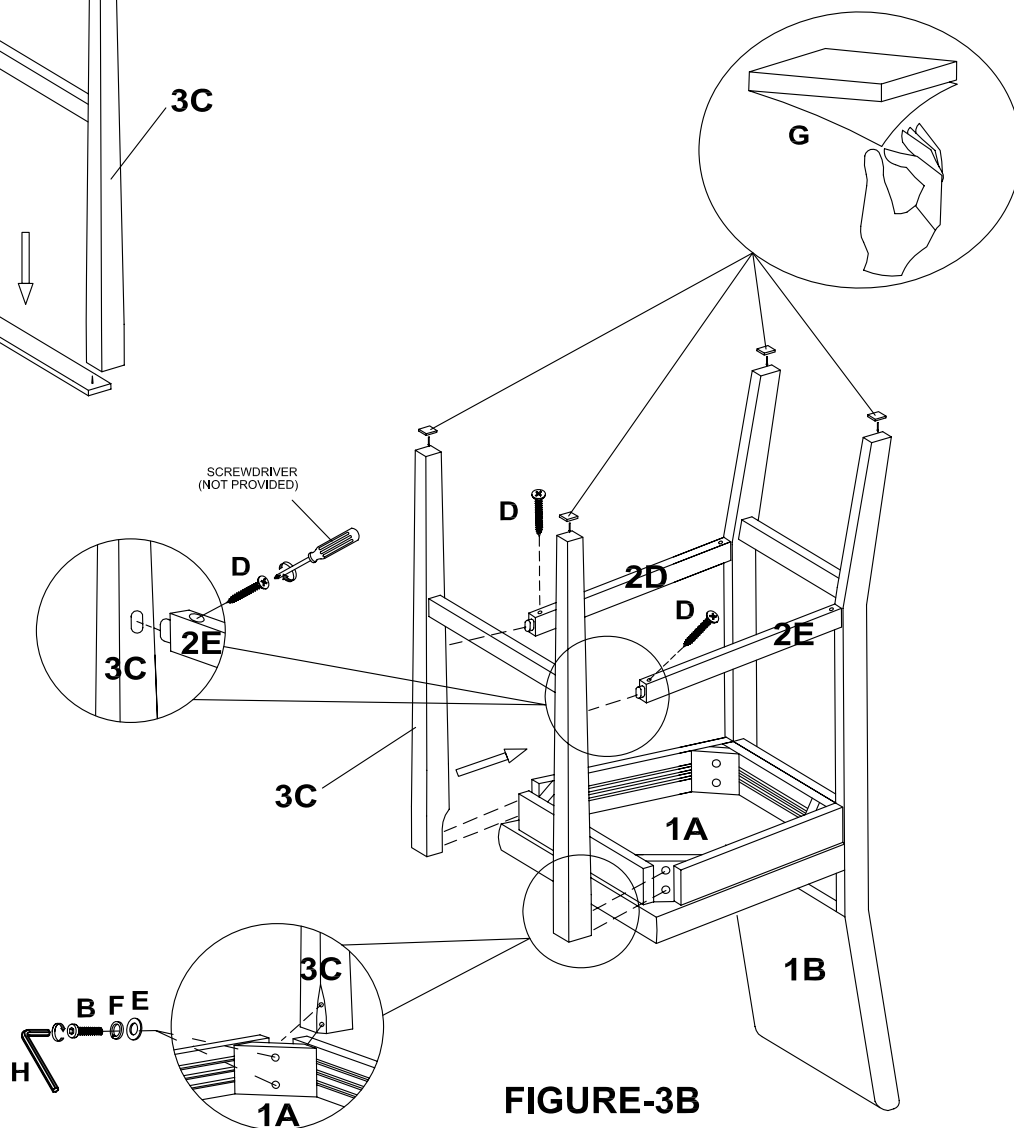

FIGURE-3B

- 3.1 REMOVE THE SHIPPING CLEAT FROM END OF FRONT LEG ASSEMBLY (3C).
- 3.2 TURN CHAIR AROUND WITH SEAT ON THE WORK SURFACE AS SHOWN IN FIGURG-3B.
- 3.3 CONNECT FRONT ASSEMBLY (3C) TO RAILS (2D) AND (2E) USING (02) WOOD SCREWS (D). THEN CONNECT IT TO SEAT (1A) USING (04) SCREWS (B).
- 3.4 ATTACH (04) ADHESIVE FELT PAD (G) TO BOTTOM OF EACH LEG TO PREVENT DAMAGE TO THE FLOOR.



LINON HOME DECOR PRODUCTS, INC.

LIMITED 6 MONTHS WARRANTY

WHAT IS COVERED

This product is covered under our manufacturer's 6 months limited warranty (Linon Home Décor Products). To ensure your complete satisfaction, this warrants to the original purchaser that the Linon supplied item is free from defects in material and workmanship, as of the date of purchase, and that it will, under normal use and proper care, remain so for six months after the date of purchase.

Replacement of missing or initially defective parts will be sent, at no charge, for a period Of 30 days from date of purchase.

WHAT IS NOT COVERED

It remains the customer's responsibility for freight and packaging charges to and from the customer service center. Labor and material charges to remove or replace parts under this warranty are not covered.

This warranty does not cover: Furniture used for commercial purposes, failures caused by improper care, unreasonable or abusive use, freeze damage, acts of God, rust, purchased parts or return freight and packaging charges. Proof of purchase (dated register receipt) is required for warranty claims.

HOW TO OBTAIN SERVICE

For further information, please contact our customer service department, c/o Linon Home Décor Products, Inc., between 9:00 AM and 5:00 PM Eastern Standard time, Monday through Friday:

LINON HOME DÉCOR PRODUCTS, INC.,
CUSTOMER SERVICE DEPARTMENT
22 JERICHO TURNPIKE
MINEOLA, NY 11501

Toll free number : 1 - 800 - 262 - 1852 Customer Service

TEL : 516-669-1000

FAX : 516-699-1001

E-MAIL : consumersupport@linon.com